

STATE OF ILLINOIS
DEPARTMENT OF TRANSPORTATION

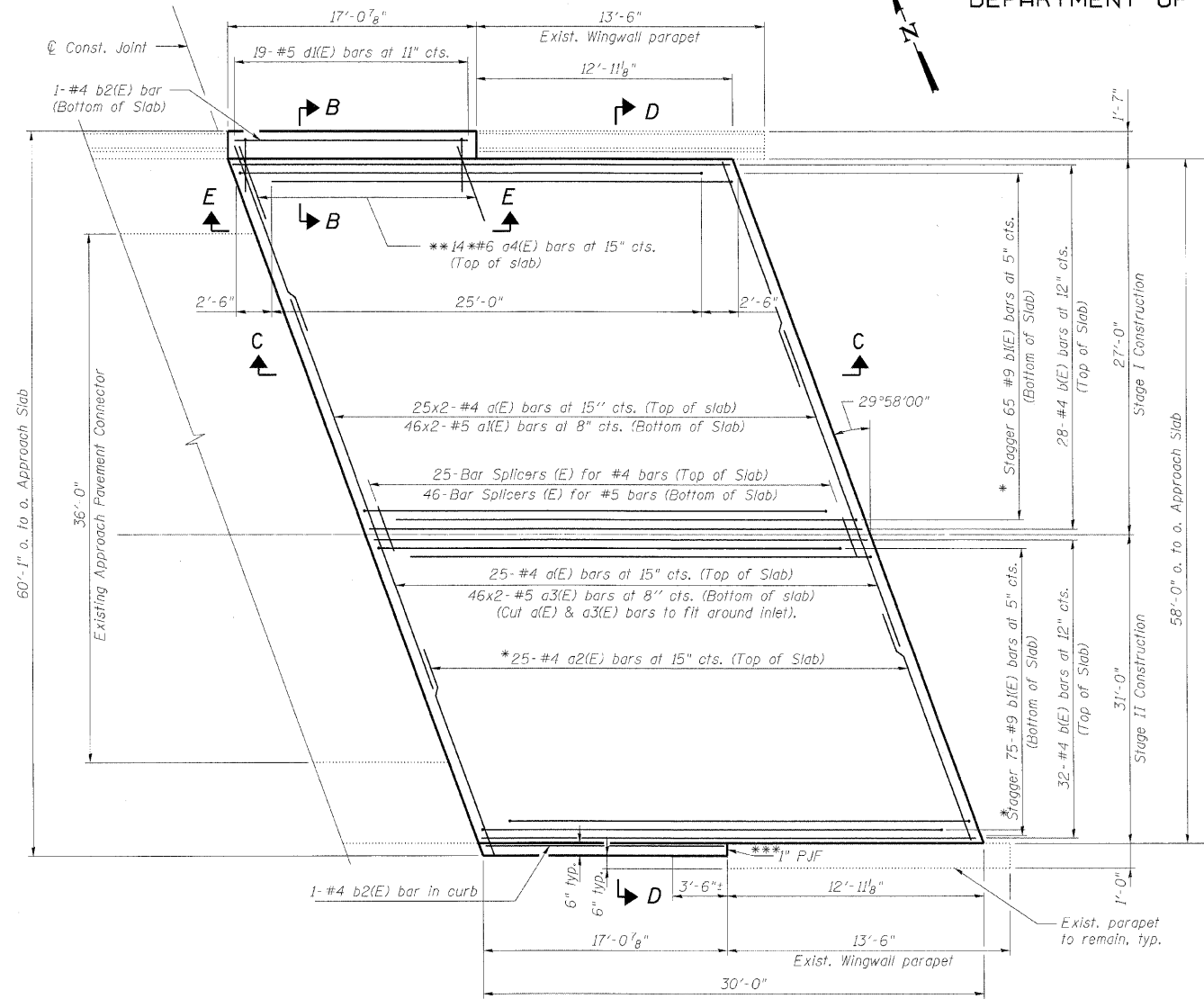

PLAN

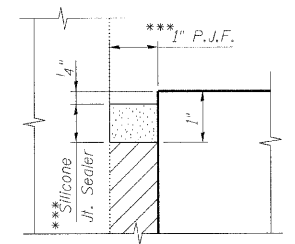

DETAIL 1

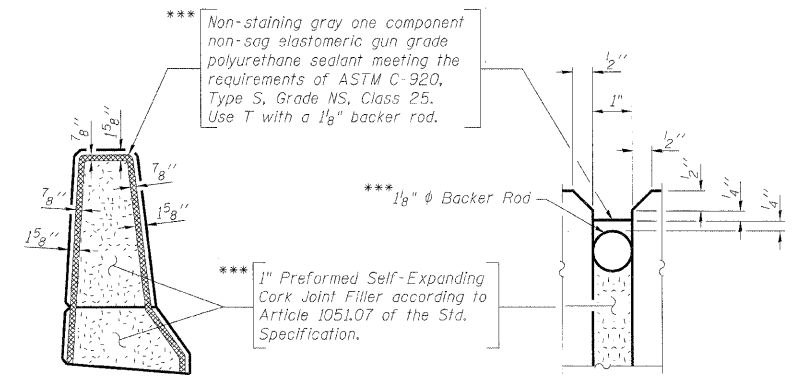

DETAIL 2

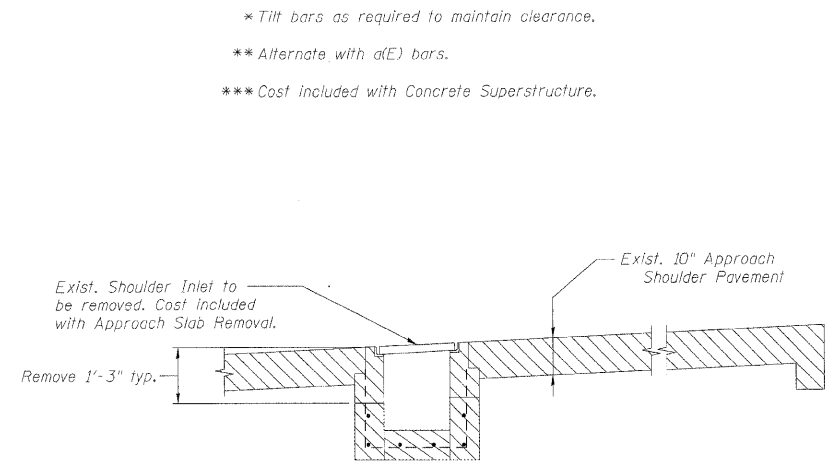

APPROACH SLAB REMOVAL DETAIL AT INLET

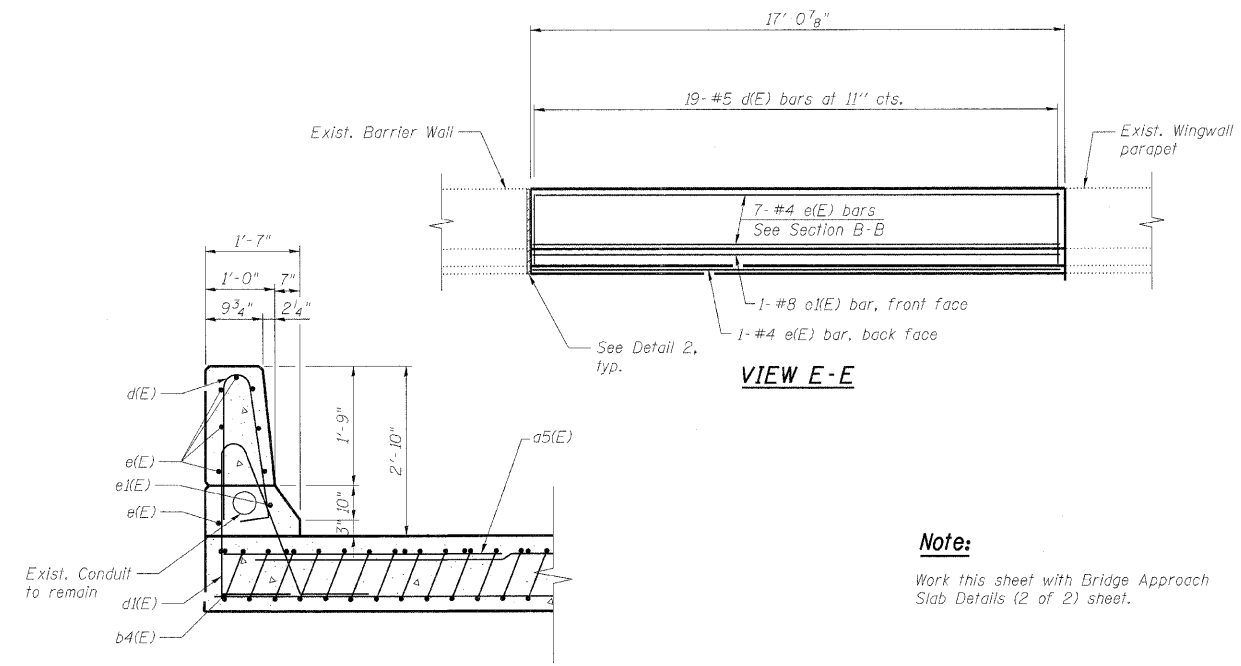

SECTION B-B

VIEW E-E

Note:
Work this sheet with Bridge Approach Slab Details (2 of 2) sheet.

DESIGNED -	MFB
CHECKED -	KWS
DRAWN -	RMC
CHECKED -	KWS

benesch
alfred benesch & company
Engineers • Surveyors • Planners
205 North Michigan Avenue, Suite 2400
Chicago, Illinois 60601
312-565-0450 Job No. 10050

SHEET NO. 6 18 SHEETS	F.A.I. RTE. 290 355	SECTION 22(1, 1-1, 2&3)RS-7	COUNTY DUPAGE	TOTAL SHEETS 546	SHEET NO. 268
	CONTRACT NO. 60G51				
FED. ROAD DIST. NO.		ILLINOIS	FED. AID PROJECT		

BRIDGE APPROACH SLAB DETAILS
(1 OF 2)
STRUCTURE NO. 022-0099

x:\10000s\10050\engineering-documents-construct-1\NSN_022_0098_0099_Church_St_0099-60G51-006-Approach_1.dgn 18:00:05 11/12/2009