

STATE OF ILLINOIS  
DEPARTMENT OF TRANSPORTATION

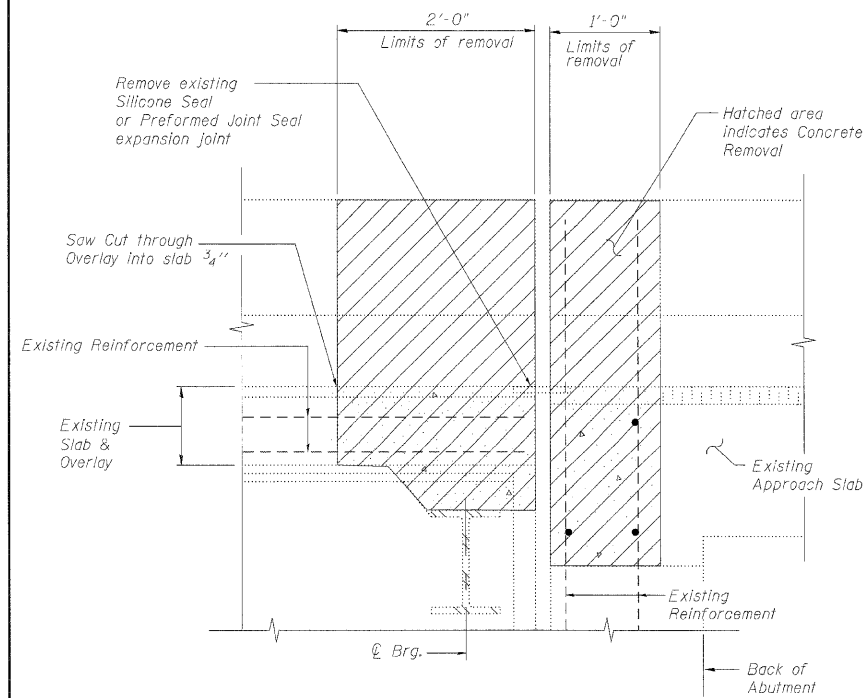

SECTION A-A

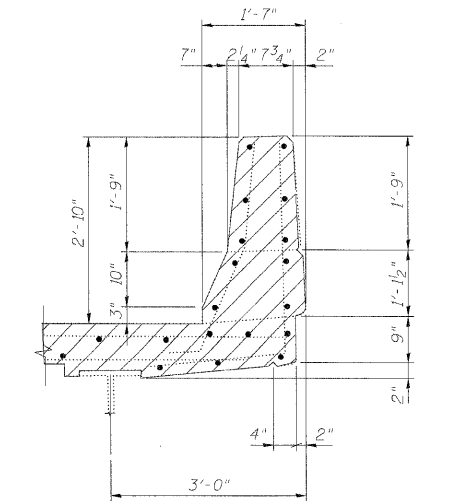

EXISTING INTERIOR PARAPET SECTION

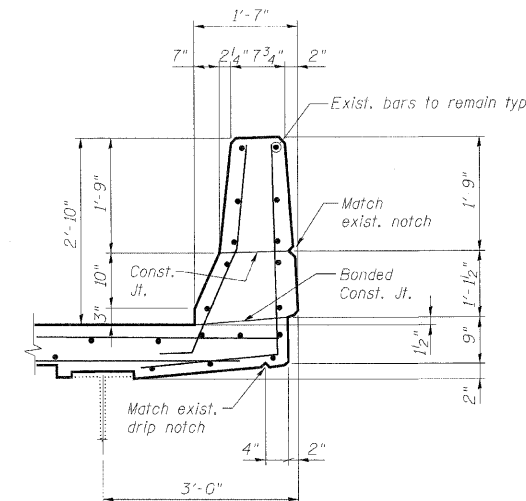

PROPOSED INTERIOR PARAPET SECTION

Notes:

- Existing reinforcement bars extending into the concrete removal area shall be blast-cleaned, straightened and incorporated into the new construction. Any reinforcement bars that are damaged during concrete removal shall be repaired or replaced with an approved bar splicer or anchorage system. Cost included with Concrete Removal.
- Existing reinforcement bars in the concrete removal area parallel to the expansion joints shall be removed.
- Removal and disposal of the existing expansion joints will not be paid for separately, but shall be included with the cost of Concrete Removal.
- If existing name plate falls within the limits of Concrete Removal, it shall be removed and reinstalled in its original location in accordance with IDOT Std. 515001. Cost included with Concrete Superstructure.
- If existing guardrail and/or end shoe fall within the limits of Concrete Removal, they shall be removed and reinstalled in their original location in accordance with District 1 Std. BM-21. Cost included with Concrete Superstructure.
- Work this sheet with Expansion Joint Repairs sheet.

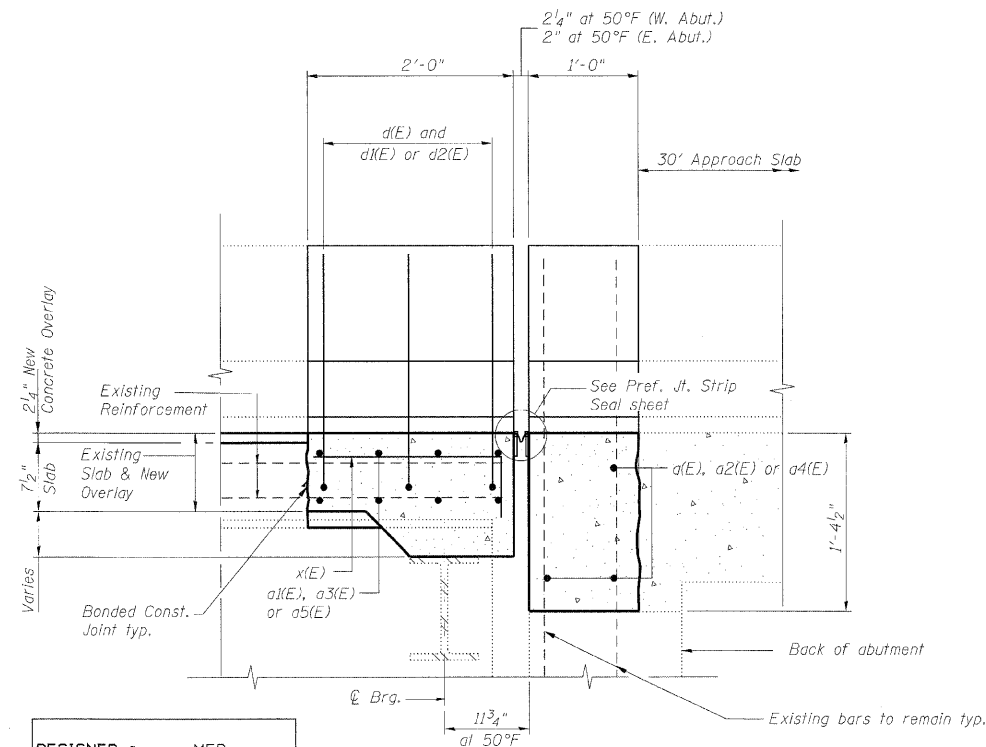

SECTION B-B

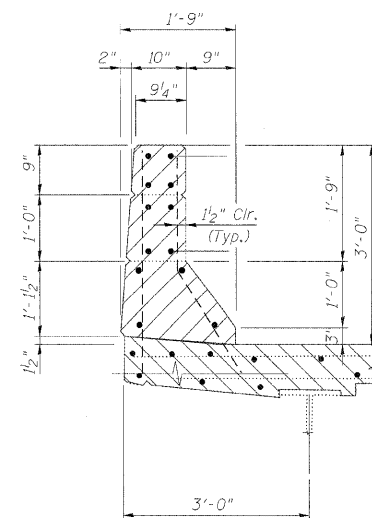

EXISTING EXTERIOR PARAPET SECTION

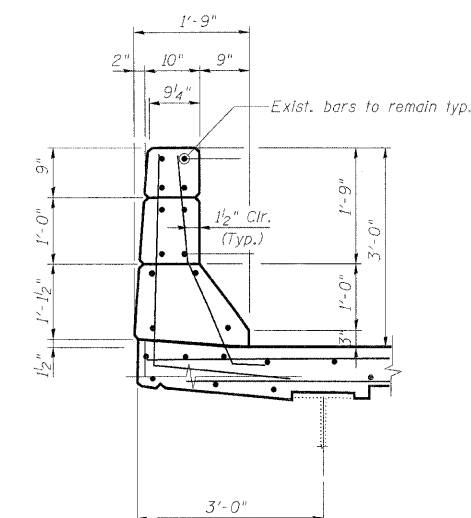

PROPOSED EXTERIOR PARAPET SECTION

DESIGNED -	MFB
CHECKED -	KWS
DRAWN -	VH
CHECKED -	KWS

benesch

alfred benesch & company  
Engineers • Surveyors • Planners  
205 North Michigan Avenue, Suite 2400  
Chicago, Illinois 60601  
312-565-0450 Job No. 10050

EXPANSION JOINT DETAILS  
STRUCTURE NO. 022-0097

SHEET NO. 6	F.A.I. RTE.	SECTION	COUNTY	TOTAL SHEETS	SHEET NO.
	290	22(1, 1-1, 2&3)RS-7	DUPAGE	546	305
9 SHEETS	CONTRACT NO. 60G51				
FED. ROAD DIST. NO.		ILLINOIS	FED. AID PROJECT		