

MOORING ROPE - 3" DIA. NYLON ROPE SHALL BE FIRST PLACED IN A 3" DIA. X 6" DP. HOLE BORED INTO THE LARGE BOLLARD & PINNED TO IT WITH A 6" LG GALV. NAIL. THE ROPE SHALL THEN BE TIGHTLY WOUND AROUND ALL THREE (3) BOLLARDS, THREE (3) COMPLETE TURNS, & PINNED WITH A 6" LG GALV. NAIL & THEN CONTINUE ON TO THE NEXT GROUPING OF BOLLARDS. THIS WORK SHALL BE DONE IN THE PRESENCE OF THE OWNER'S REPRESENTATIVE.

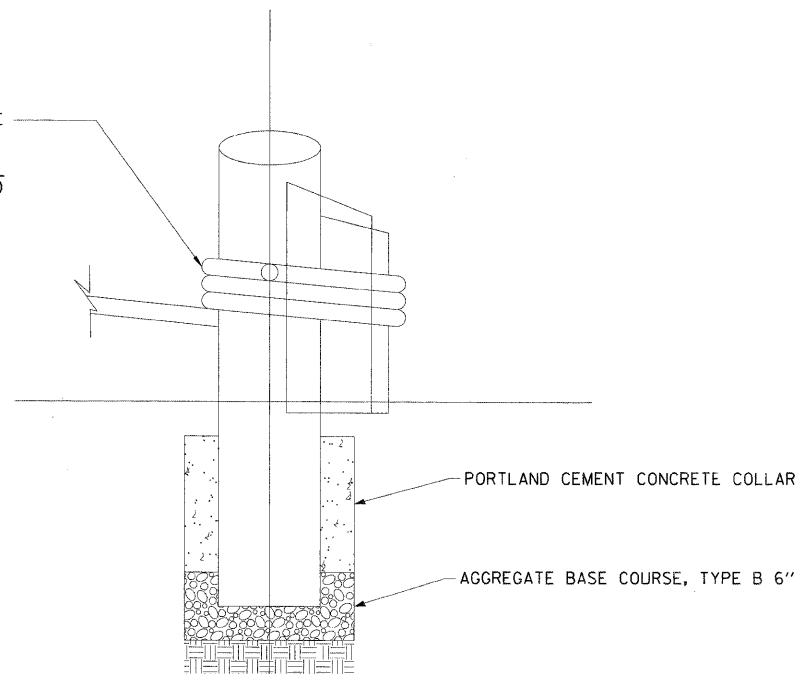

LANDSCAPE ROPE - ELEVATION

PLAN VIEW

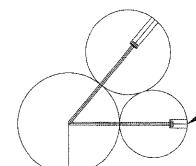

WOOD BOLLARDS - SHALL BE PINNED TOGETHER WITH TWO (2) 1/2" DIA. X 18' LG. GALV. HEX LAG SCREWS FROM EACH OF SMALLER BOLLARD INTO THE LARGE BOLLARD 9" DP. A 7/16" DIA. PILOT HOLE SHALL BE DRILLED FIRST FOLLOWED BY A 1 1/2" DIA. COUNTERBORE TO THE DEPTH NECESSARY SO THAT THE SCREW EXTENDS INTO THE LARGE BOLLARD 9" DEEP. THEN PLACE & GLUE IN THE COUNTERBORE HOLE A 1 1/2" DIA. X 3" LG. WOOD PLUG. SAND EXPOSED END SMOOTH TO MEET BOLLARD EXTERIOR. PRIOR TO FASTENING THE BOLLARDS TOGETHER ROTATE THE BOLLARDS TO FIND THE BEST PLACE TO FIT & BUTT THEM TOGETHER. THIS SHALL BE DONE IN THE PRESENCE OF THE OWNER'S REPRESENTATIVE.

WOOD BOLLARDS - 12" DIA, 15" DIA. & 18" DIA., THE LARGEST SHALL EXTEND TO 4'0" BELOW GRADE, THE OTHERS 2 1/2" BELOW GRADE. THE LENGTH OF EACH SHALL BE AS SHOWN WITH THE TOPS CUT ON VARIOUS ANGLES TO SHED WATER.

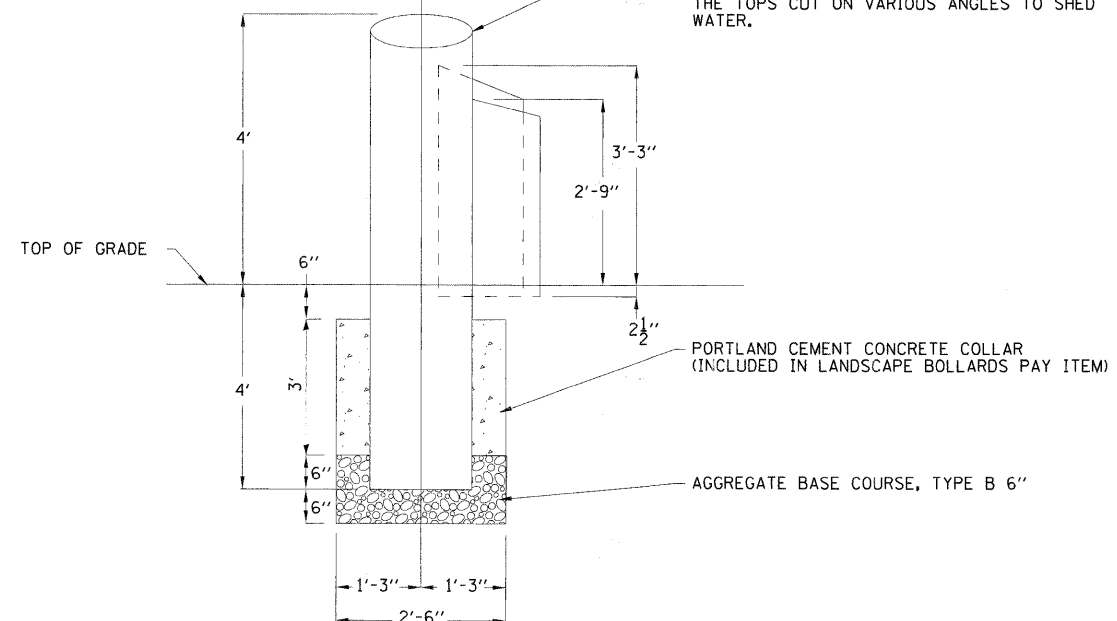

LANDSCAPE BOLLARDS - SECTION

LANDSCAPE ROPE AND LANDSCAPE BOLLARDS DETAIL

COPYRIGHT © 2009 BY BAXTER & WOODMAN, INC.
 STATE OF ILLINOIS - PROFESSIONAL DESIGN FIRM
 LICENSE NO. 184-00121 - EXPIRES 4/30/2011
 10/16/2009 4:05:07 PM
 I:\WINNR\060807\CDMS\enr\enr\060807-lands-def-1.sht



| | |
|----------------|-------------------------------|
| DESIGNED - MWP | REVISED - IDOT REVIEW 2/19/09 |
| DRAWN - | REVISED - IDOT REVIEW 4/22/09 |
| CHECKED - MDW | REVISED - |
| DATE - 8-1-08 | FILE - 060807-lands-def-1.sht |

VILLAGE OF WINTHROP HARBOR, ILLINOIS
 ILLINOIS ROUTE 137 (SHERIDAN ROAD) AND 7th STREET
 STREETScape IMPROVEMENTS

LANDSCAPING DETAILS

SCALE: NONE

STA. TO STA.

| | | | | |
|-----------------------|----------------|--|--------------|-----------|
| F.A.P. RTE. | SECTION | COUNTY | TOTAL SHEETS | SHEET NO. |
| * | 06-00036-00-LS | LAKE | 70 | 40 |
| FED. ROAD DIST. NO. 1 | | CONTRACT NO. 63167 | | |
| JOB NO. C-91-197-10 | | ILLINOIS FED. AID PROJECT ARA-00016101 | | |

* F.A.P. 352 ILLINOIS ROUTE 137 (SHERIDAN ROAD)