

LENGTH OF SLACK FOR LOOP LEAD-INS SHALL PROVIDE FOR MAKING THE SPLICE ON TOP OF THE HANDHOLE AND ONE COMPLETE LOOP OF THE INTERIOR OF THE HANDHOLE, THE SPLICE SHALL BE SUPPORTED BY A CABLE HOOK.

THE LOOP LEAD-IN CONDUIT HOLES SHALL BE PLACED AS CLOSE TO THE CURB AS POSSIBLE TO PERMIT SAW OVERLAP WITHOUT SCARRING FACE OF CURB.
IN NON-CURB LOCATIONS THE DISTANCE SHALL NOT BE LESS THAN 150 mm (6").

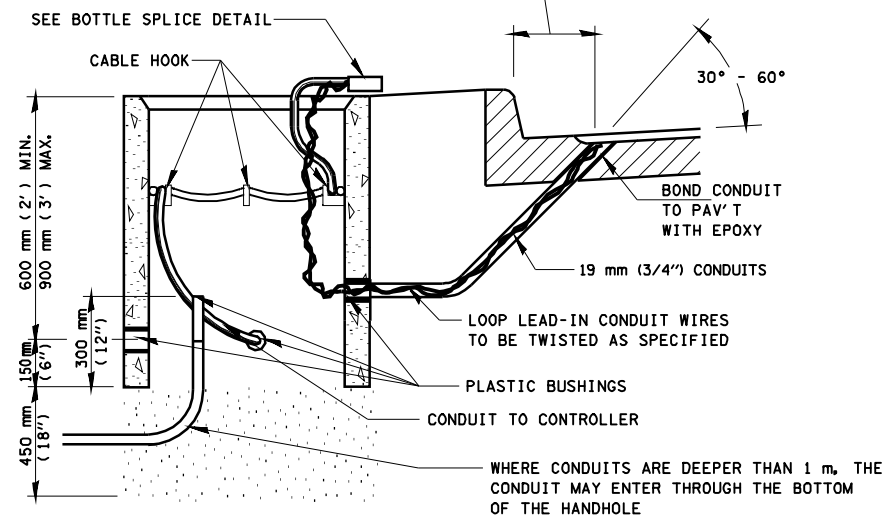

HANDHOLE CABLE CONNECTIONS

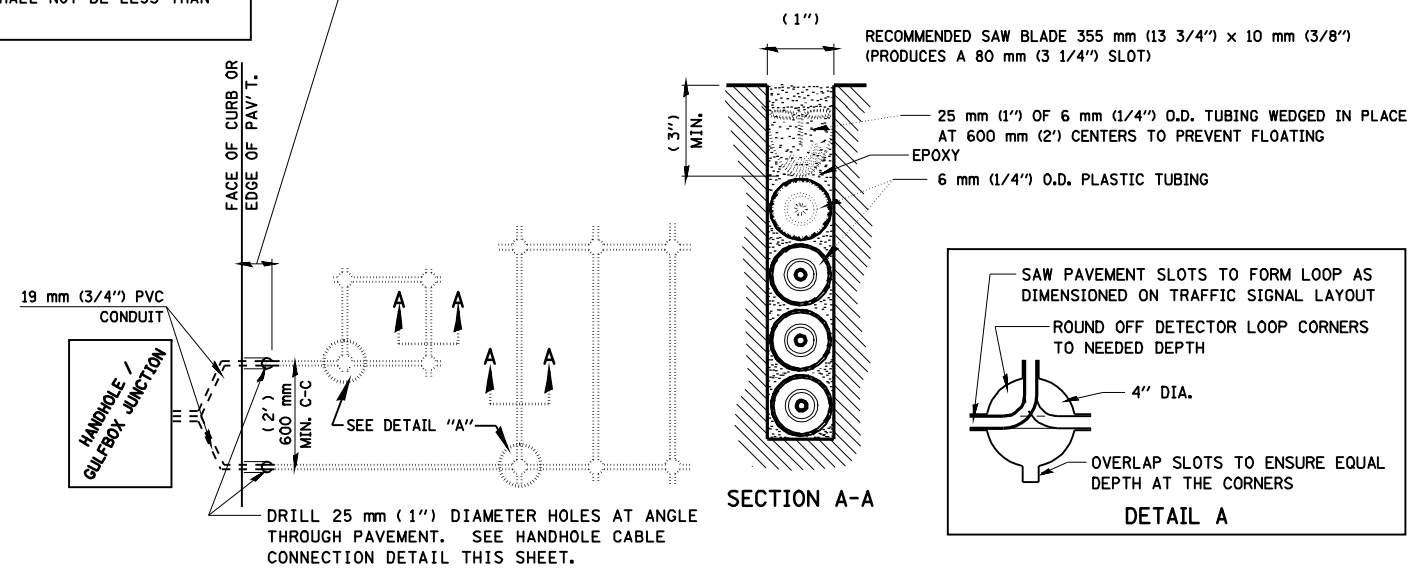

PAVEMENT SAWING DETAIL FOR TUBE ENCASED DETECTOR LOOP WIRE

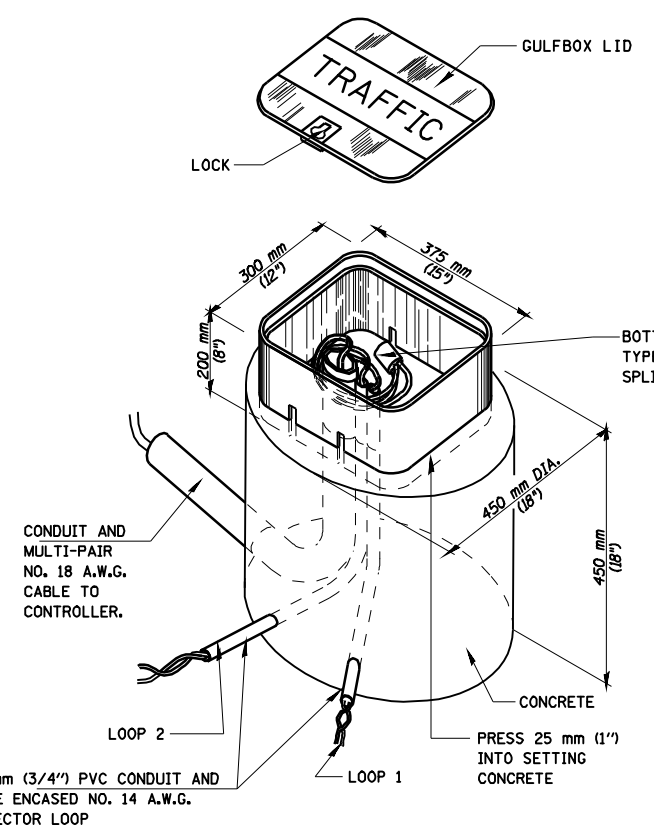

GULFBOX JUNCTION DETAIL

(SHOWING CONNECTION OF TUBE-ENCASED DETECTOR LOOP TO MULTI-PAIR LEAD-IN CABLE)

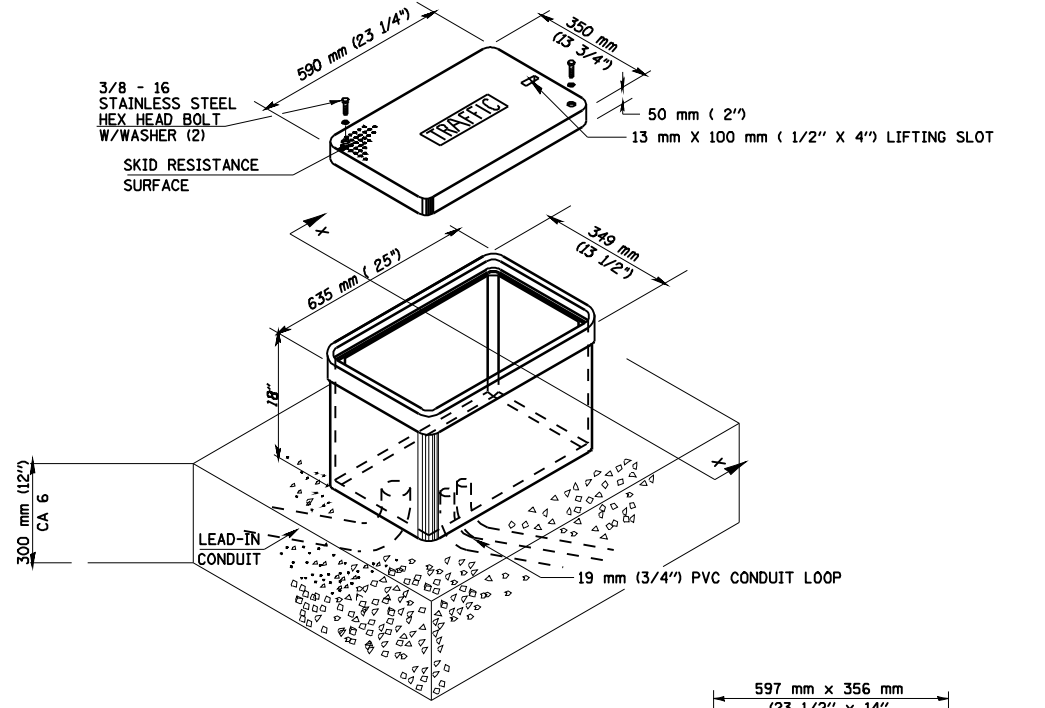

JUNCTION BOX (SPECIAL)

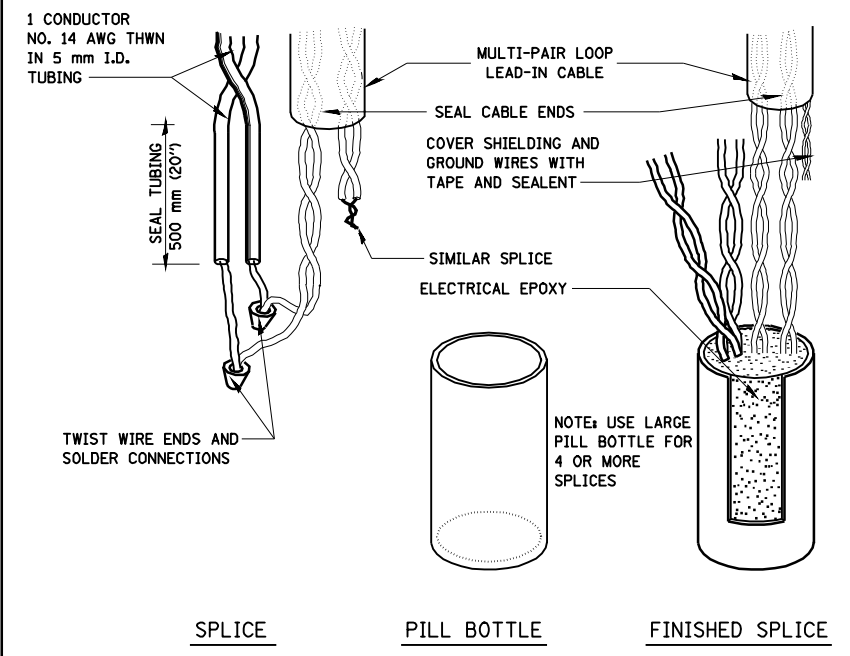
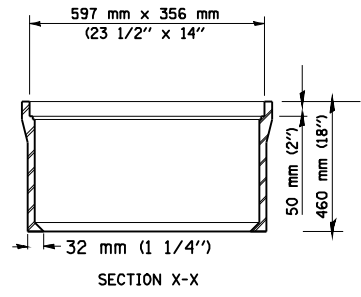

BOTTLE SPLICE DETAIL