

STA. 779+75.54 - 794+90.66, RT.  
 STA. 791+54.84 - 807+23.33, LT.

STATION EQUATION  
 STA. 805+56.11 (BK) =  
 STA. 806+23.33 (AH)

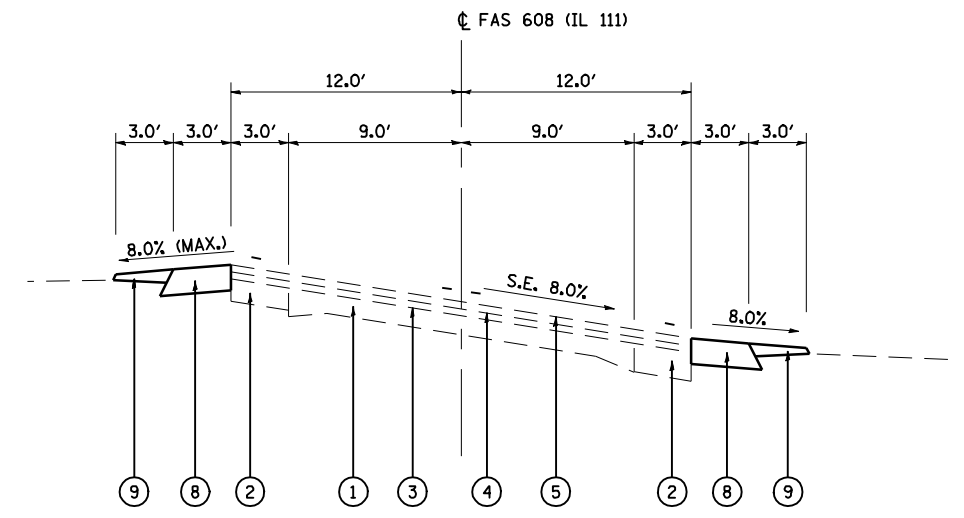

STA. 943+37.62 - 953+11.05  
 STA. 964+60.34 - 976+40.43  
 STA. 1048+85.79 - 1059+16.98  
 STA. 1228+51.24 - 1238+57.09  
 STA. 1410+02.65 - 1443+62.18  
 STA. 1486+73.83 - 1512+10.23  
 STA. 1548+92.61 - 1553+62.05

STATION EQUATION  
 STA. 1411+02.68 (BK) =  
 STA. 1422+80.00 (AH)

**LEGEND**

- ① EXIST. PCC PAVEMENT (9-6-9)
- ② EXIST. BITUMINOUS CONCRETE BASE COURSE WIDENING (9")
- ③ EXIST. HMA LEVELING BINDER
- ④ EXIST. LEVELING BINDER, MIX C TY 2 (1")
- ⑤ EXIST. HMA SURFACE COURSE, MIX C, CLASS I, TY 2 (1 1/2")
- ⑥ EXIST. HMA SHOULDERS (6")
- ⑦ EXIST. STRIP REFLECTIVE CRACK CONTROL TREATMENT
- ⑧ PROP. HOT-MIX ASPHALT SHOULDERS (8")
- ⑨ PROP. AGGREGATE SHOULDERS, TYPE B

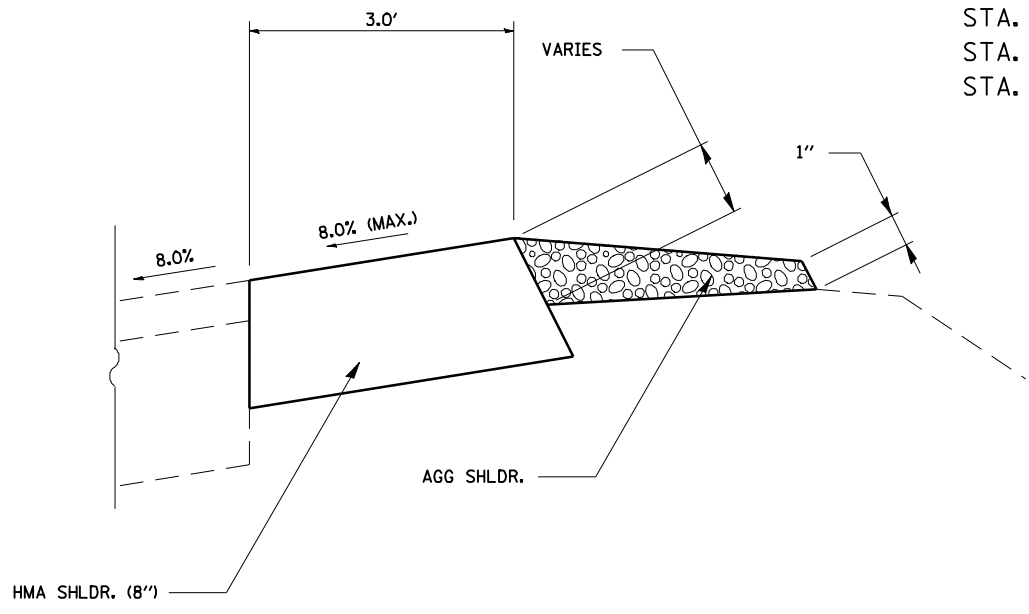

**AGGREGATE SHOULDER DETAIL**  
 (TYPICAL)

STATION EQUATION  
 STA. 942+91.74 (BK) =  
 STA. 943+00.00 (AH)

STA. 987+62.52 (BK) =  
 STA. 987+10.00 (AH)

STA. 1024+99.09 (BK) =  
 STA. 1026+71.00 (AH)

STA. 1132+02.99 (BK) =  
 STA. 1134+35.77 (AH)

STA. 1350+99.92 (BK) =  
 STA. 1353+99.87 (AH)

FILE NAME =	USER NAME = laughlinr1	DESIGNED -	REVISED -	<b>STATE OF ILLINOIS DEPARTMENT OF TRANSPORTATION</b>	<b>TYPICAL SECTIONS</b>				F.A.P. RTE.	SECTION	COUNTY	TOTAL SHEETS	SHEET NO.
et:\pwork\PWIDOT\LAUGHLINRL\0136657\0672c97-ah-typical.dgn		DRAWN -	REVISED -		608	122, 125, 126, INT-SHLD	MACOUPIN	15	4				
PLOT SCALE = 10.0000' / IN.		CHECKED -	REVISED -		SCALE: SHEET NO. OF SHEETS STA. TO STA.				CONTRACT NO. 72C97				
PLOT DATE = Oct-13-2009 10:41:40AM		DATE -	REVISED -		ILLINOIS FED. AID PROJECT								