

**PARAPET TO CURB TRANSITION
PILE BENT ABUTMENT**

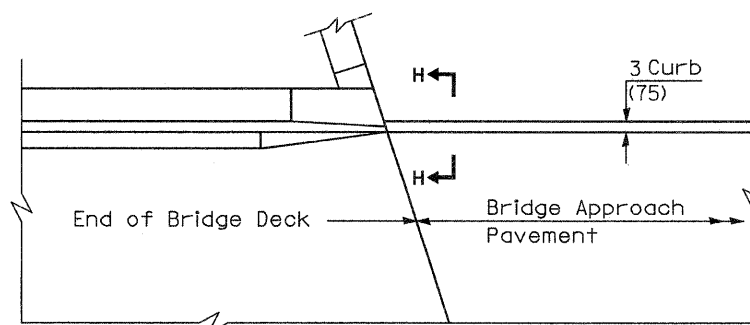

**PARAPET TO CURB TRANSITION
INTEGRAL ABUTMENT**

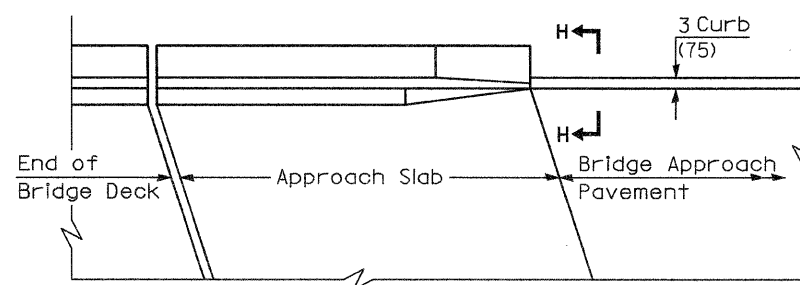

**PARAPET TO CURB TRANSITION
VAULTED ABUTMENT**

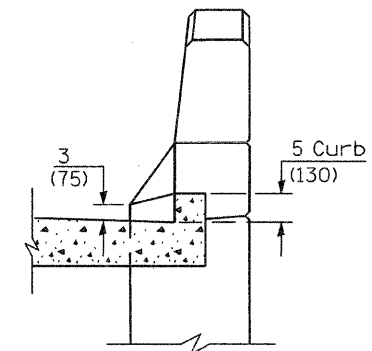

SECTION I - I

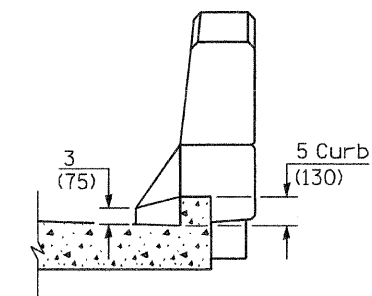

SECTION H - H

Illinois Department of Transportation

APPROVED January 1, 2008
Ralph E. Anderson
 ENGINEER OF BRIDGES AND STRUCTURES

ISSUED 1-1-97

APPROVED January 1, 2008
Ken S. Han
 ENGINEER OF DESIGN AND ENVIRONMENT

BRIDGE APPROACH PAVEMENT

(Sheet 4 of 4)

Contract 76391 Sheet 33