

**PARAPET TO CURB TRANSITION
PILE BENT ABUTMENT**

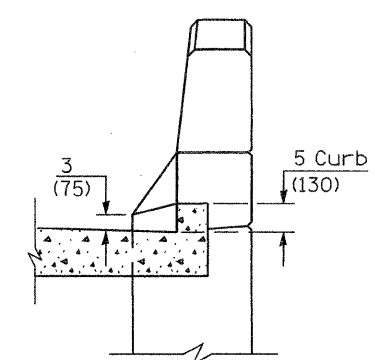

SECTION I - I

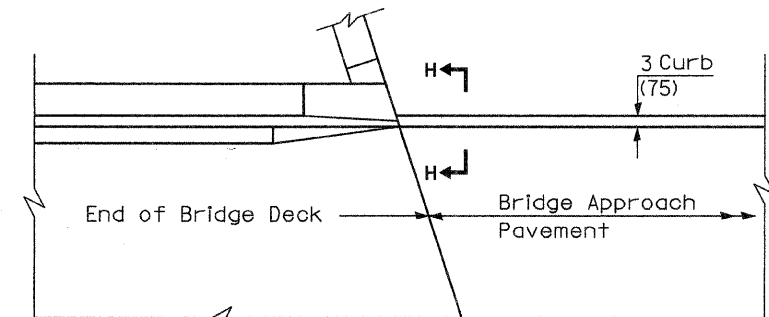

**PARAPET TO CURB TRANSITION
INTEGRAL ABUTMENT**

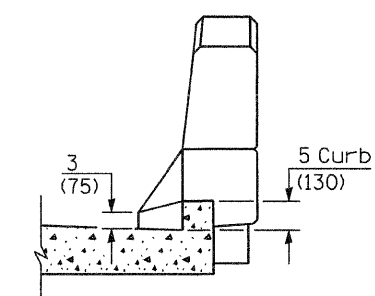

SECTION H - H

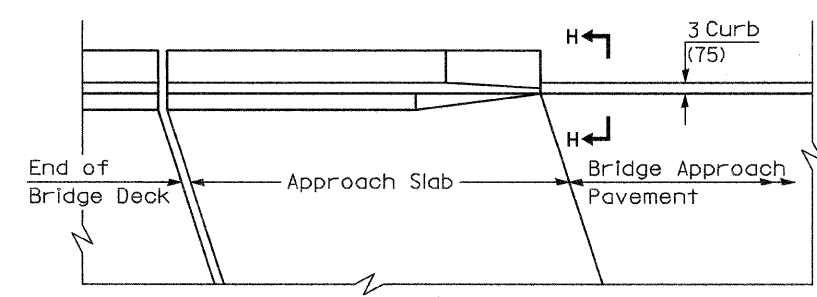

**PARAPET TO CURB TRANSITION
VAULTED ABUTMENT**

Illinois Department of Transportation
 APPROVED January 1, 2008
Ralph E. Anderson
 ENGINEER OF BRIDGES AND STRUCTURES
 APPROVED January 1, 2008
Ken E. Haas
 ENGINEER OF DESIGN AND ENVIRONMENT
 ISSUED 1-1-97

BRIDGE APPROACH PAVEMENT
 (Sheet 4 of 4)
 Contract 76B58 Sheet 37I.