

BILL OF MATERIALS

ITEM	UNIT	QUANTITY
CONDUIT IN TRENCH, 2" DIA., PVC	FOOT	174
CONDUIT IN TRENCH, 2 1/2" DIA., PVC	FOOT	76
CONDUIT IN TRENCH, 3" DIA., PVC	FOOT	18
CONDUIT IN TRENCH, 4" DIA., PVC	FOOT	10
CONDUIT AUGERED, 4" DIA., PVC	FOOT	230
CONDUIT AUGERED, 5" DIA., PVC	FOOT	140
HANDHOLE, PORTLAND CEMENT CONCRETE	EACH	3
DOUBLE HANDHOLE, PORTLAND CEMENT CONCRETE	EACH	1
TRENCH AND BACKFILL FOR ELECTRICAL WORK	FOOT	44
TRENCH AND BACKFILL WITH SCREENINGS OR SAND	FOOT	234
FULL-ACTUATED CONTROLLER AND TYPE IV CABINET, SPECIAL	EACH	1
ELECTRIC CABLE IN CONDUIT, SIGNAL, NO. 14 2C	FOOT	740
ELECTRIC CABLE IN CONDUIT, SIGNAL, NO. 14 3C	FOOT	1490
ELECTRIC CABLE IN CONDUIT, SIGNAL, NO. 14 5C	FOOT	2180
ELECTRIC CABLE IN CONDUIT, SIGNAL, NO. 14 7C	FOOT	2690
PEDESTRIAN PUSH-BUTTON POST, TYPE II	EACH	2
STEEL MAST ARM ASSEMBLY AND POLE, 38 FT. (SPECIAL)	EACH	1
STEEL MAST ARM ASSEMBLY AND POLE, 48 FT. (SPECIAL)	EACH	1
STEEL COMBINATION MAST ARM ASSEMBLY AND POLE 38 FT. (SPECIAL)	EACH	1
STEEL COMBINATION MAST ARM ASSEMBLY AND POLE 50 FT. (SPECIAL)	EACH	1
CONCRETE FOUNDATION, TYPE A	FOOT	12
CONCRETE FOUNDATION, TYPE D	FOOT	3.5
CONCRETE FOUNDATION, TYPE E 36-INCH DIAMETER	FOOT	60
SIGNAL HEAD, POLYCARBONATE, LED, 1-FACE, 3-SECTION, BRACKET MOUNTED	EACH	4
SIGNAL HEAD, POLYCARBONATE, LED, 1-FACE, 3-SECTION, MAST ARM MOUNTED	EACH	6
SIGNAL HEAD, POLYCARBONATE, LED, 1-FACE, 5-SECTION, BRACKET MOUNTED	EACH	6
SIGNAL HEAD, POLYCARBONATE, LED, 1-FACE, 5-SECTION, MAST ARM MOUNTED	EACH	6
PEDESTRIAN SIGNAL HEAD, POLYCARBONATE, LED, 1-FACE, BRACKET MOUNTED	EACH	8
TRAFFIC SIGNAL BACKPLATE	EACH	12
ELECTRIC CABLE IN CONDUIT, GROUNDING, NO. 6 1C	FOOT	750
EMERGENCY VEHICLE PRIORITY SYSTEM	EACH	1
PEDESTRIAN PUSH-BUTTON, SPECIAL	EACH	4
INTERNALLY ILLUMINATED STREET NAME SIGN	EACH	4
TRAFFIC SIGNAL POST, 10 FOOT (SPECIAL)	EACH	2
TRAFFIC SIGNAL POST, 14 FOOT (SPECIAL)	EACH	2
WIRELESS VEHICLE DETECTION SYSTEM	EACH	1

• SEE TECHNICAL SPECIFICATIONS FOR SYSTEM GROUNDING INFORMATION.

TRAFFIC SIGNAL GENERAL NOTES

- THE ACTUAL LOCATIONS OF ALL SIGNAL FOUNDATIONS, HANDHOLES, AND THE TRAFFIC SIGNAL CONTROLLER WILL BE VERIFIED IN THE FIELD BY THE ENGINEER.
- POST MOUNTED SIGNAL HEADS SHALL BE INSTALLED SUCH THAT NO PART OF THE SIGNAL HEAD IS WITHIN TWO (2) FEET OF THE FACE OF CURB. MAST ARM POLES SHALL BE PLACED SUCH THAT A MINIMUM DISTANCE OF SIX (6) FEET IS MAINTAINED BETWEEN THE CENTER OF THE POLE AND THE FACE OF CURB (ON THE MAST ARM SIDE).
- THE TOP BRACKET FOR A SIGNAL HEAD MOUNTED TO A TAPERED LIGHT POLE SHALL BE SHIMMED AS REQUIRED BY THE INSTALLATION.
- 12" LENSES SHALL BE USED ON ALL SIGNAL FACES.
- THE LUMINAIRE ARM, LUMINAIRE POLE WIRING, AND LUMINAIRE SHALL BE ERECTED WITH THE TRAFFIC SIGNAL MAST ARM POLE. REFER TO THE ROADWAY LIGHTING PLANS FOR LUMINAIRE TYPE AND QUANTITY.
- MAST ARM FOUNDATIONS SHALL INCLUDE A SEPARATE STUB AND CAP FOR ROADWAY LIGHTING CABLE, ROADWAY LIGHTING CABLE AND TRAFFIC SIGNAL CABLE SHALL NOT SHARE THE SAME CONDUIT. ROADWAY LIGHTING CABLE AND INTERNALLY ILLUMINATED STREET NAME SIGN CABLE SHALL BE INSTALLED IN THE SAME CONDUIT. REFER TO THE ROADWAY LIGHTING PLANS FOR ADDITIONAL INFORMATION.
- THE CONTRACTOR SHALL VERIFY THE EXACT LOCATION OF ALL UNDERGROUND UTILITIES PRIOR TO BEGINNING CONSTRUCTION.
- A 1/4" CONTINUOUS NYLON ROPE SHALL BE FURNISHED AND LEFT IN PLACE IN ALL CONDUITS BETWEEN HANDHOLES, FOUNDATIONS, AND CONTROLLERS. THE ROPE SHALL BE INCLUDED IN THE COST OF THE RESPECTIVE CONDUIT PAY ITEM.
- THE TRAFFIC SIGNAL CONTROLLER AND THE TRAFFIC SIGNAL EQUIPMENT SHALL RECEIVE POWER FROM THE ROADWAY LIGHTING CONTROLLER. FOR ELECTRICAL SERVICE INFORMATION, REFER TO THE ROADWAY LIGHTING PLANS AND THE TECHNICAL SPECIFICATIONS.
- THE TRAFFIC SIGNAL CONTROLLER SHALL BE ORIENTED SUCH THAT INTERSECTION OPERATION AND CONTROLLER COMPONENTS CAN BE VIEWED SIMULTANEOUSLY.
- CONTROLLER PROGRAMMING OF SIGNAL TIMING WILL BE PROVIDED BY THE CITY OF CHAMPAIGN.
- THE NECESSARY CONNECTIONS FOR PROPER OPERATION OF THE EMERGENCY VEHICLE PRIORITY SYSTEM, INCLUDING ALL INSTALLATION CABLES, SHALL BE INCLUDED IN THE COST OF THE EMERGENCY VEHICLE PRIORITY SYSTEM.
- THE RADIO/GPS CABLE FOR THE EMERGENCY VEHICLE PRIORITY SYSTEM SHALL BE A CONTINUOUS UNBROKEN RUN FROM THE RADIO/GPS UNIT TO THE PHASE SELECTOR. SPLICES IN THE CABLE SHALL NOT BE ALLOWED.
- THE NECESSARY CONNECTIONS FOR PROPER OPERATION OF THE WIRELESS VEHICLE DETECTION SYSTEM, INCLUDING ALL INSTALLATION CABLES, SHALL BE INCLUDED IN THE COST OF THE WIRELESS VEHICLE DETECTION SYSTEM.
- THE POWER OVER ETHERNET (POE) CABLE FOR THE WIRELESS VEHICLE DETECTION SYSTEM SHALL BE A CONTINUOUS UNBROKEN RUN FROM THE ACCESS POINT TO THE ACCESSBOX. SPLICES IN THE CABLE SHALL NOT BE ALLOWED.
- THE NECESSARY CONNECTIONS FOR PROPER OPERATION OF THE INTERNALLY ILLUMINATED STREET NAME SIGN SHALL BE INCLUDED IN THE COST OF THE INTERNALLY ILLUMINATED STREET NAME SIGN. THE ELECTRIC CABLE WILL BE PAID FOR SEPARATELY. REFER TO THE ROADWAY LIGHTING PLANS FOR ADDITIONAL INFORMATION.
- A PEDESTRIAN PUSH-BUTTON SIGN WILL BE MOUNTED ABOVE EACH PEDESTRIAN PUSH-BUTTON. THE PEDESTRIAN PUSH-BUTTON SIGNS WILL BE FURNISHED AND INSTALLED BY THE CITY OF CHAMPAIGN.
- THE CONCRETE FOUNDATION FOR THE PEDESTRIAN PUSH-BUTTON POST SHALL BE INCLUDED IN THE COST OF THE PEDESTRIAN PUSH-BUTTON POST, TYPE II.

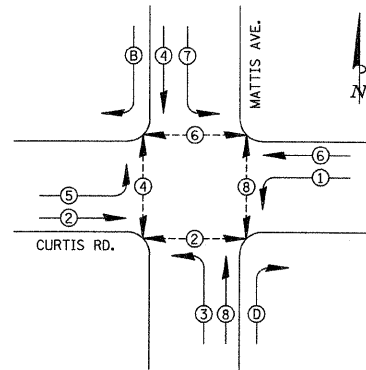

PHASE DESIGNATION DIAGRAM

PHASE DESIGNATION DIAGRAM LEGEND

- ⊛ DUAL ENTRY PHASE * NUMBER REFERS TO ASSOCIATED PHASE
- ⊛ PEDESTRIAN PHASE
- ⊛ RIGHT TURN OVERLAP
B = 5
D = 1

** THE CABLE FOR THE INTERNALLY ILLUMINATED STREET NAME SIGNS SHALL BE INSTALLED FROM EACH SIGN TO ROADWAY LIGHTING CONTROLLER #75. THE CABLE SHALL BE INSTALLED IN THE ROADWAY LIGHTING CONDUIT. REFER TO THE ROADWAY LIGHTING PLANS FOR ADDITIONAL INFORMATION.

F.A.P. RTE.	SECTION	COUNTY	TOTAL SHEETS	SHEET NO.
807	00-00374-01-PV	CHAMPAIGN	242	129
STA.	TO STA.			
	ILLINOIS	F.A. PROJ. NO. RS-HPP-1805(000)		
CONTRACT NO. 91368				

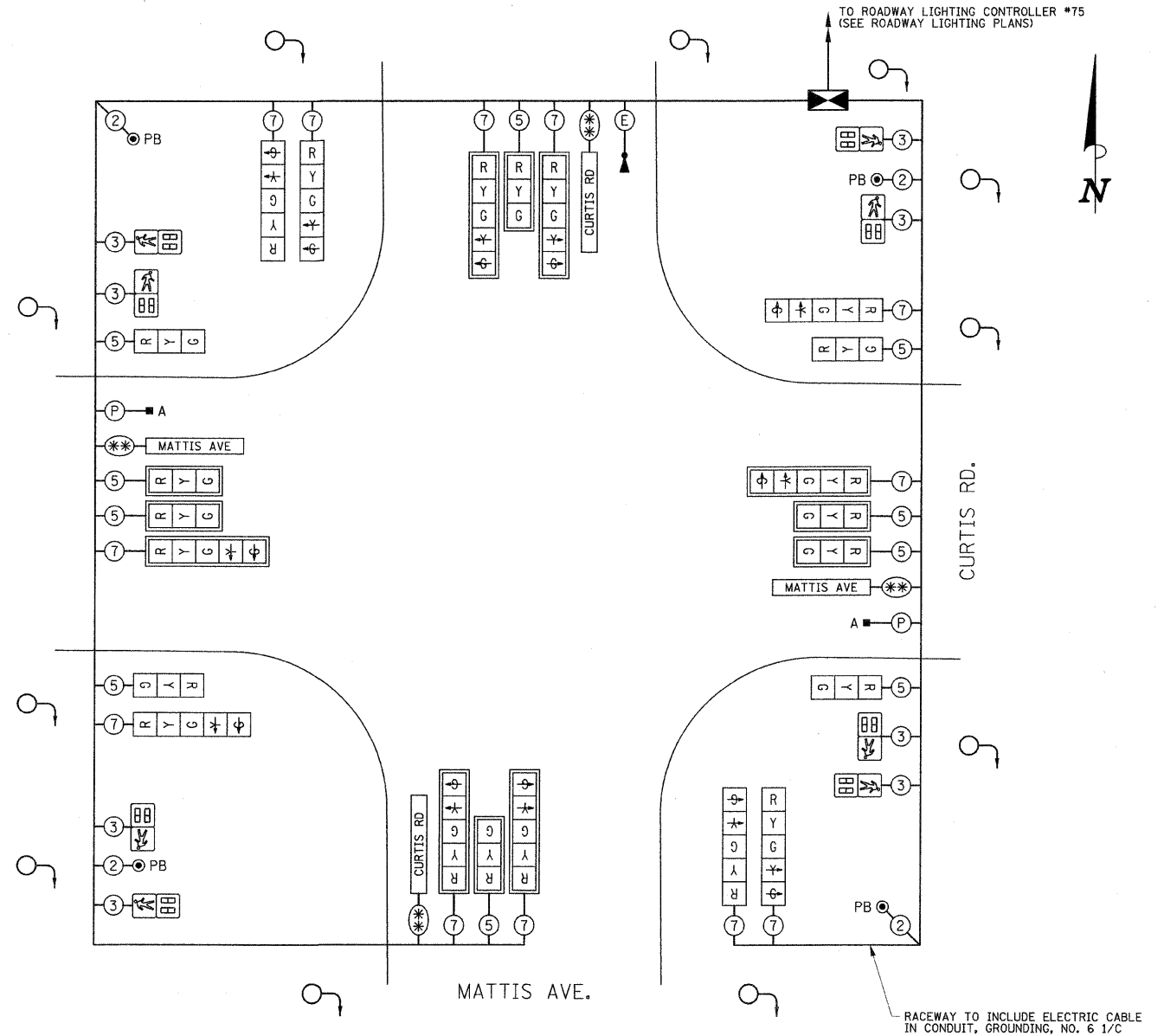

CABLE DIAGRAM

CABLE DIAGRAM LEGEND

- ⊞ CONTROLLER CABINET
- ⊞ SIGNAL FACE
- ⊞ SIGNAL FACE AND BACKPLATE
- ⊛ PB PEDESTRIAN PUSH-BUTTON
- ⊞ PEDESTRIAN SIGNAL FACE
- ⊞ EMERGENCY VEHICLE PRIORITY SYSTEM RADIO/GPS UNIT
- ⊞ EMERGENCY VEHICLE PRIORITY SYSTEM RADIO/GPS CABLE SEE TECHNICAL SPECIFICATIONS
- ⊞ WIRELESS VEHICLE DETECTION SYSTEM ACCESS POINT
- ⊞ WIRELESS VEHICLE DETECTION SYSTEM POE CABLE SEE TECHNICAL SPECIFICATIONS
- ⊞ DENOTES NUMBER OF CONDUCTORS ALL CABLE NO. 14 EXCEPT AS INDICATED
- ⊞ GROUNDING SYSTEM CONNECTION

ILLINOIS DEPARTMENT OF TRANSPORTATION
CURTIS ROAD & MATTIS AVENUE
 TRAFFIC SIGNAL PLANS
 CABLE DIAGRAM/PHASE DESIGNATION DIAGRAM/
 TRAFFIC SIGNAL GENERAL NOTES/BILL OF MATERIALS
 DATE : 10-08
 DRAWN BY : J.A.J.
 CHECKED BY : R.L.H.
 SCALE : NONE