

**ELECTRICAL SERVICE - PANEL DIAGRAM (TYPICAL FOR POLE AND GROUND MOUNTED SERVICE)**  
**SERVICE INSTALLATION POLE MOUNT (SHOWN)**  
 (NOT TO SCALE)

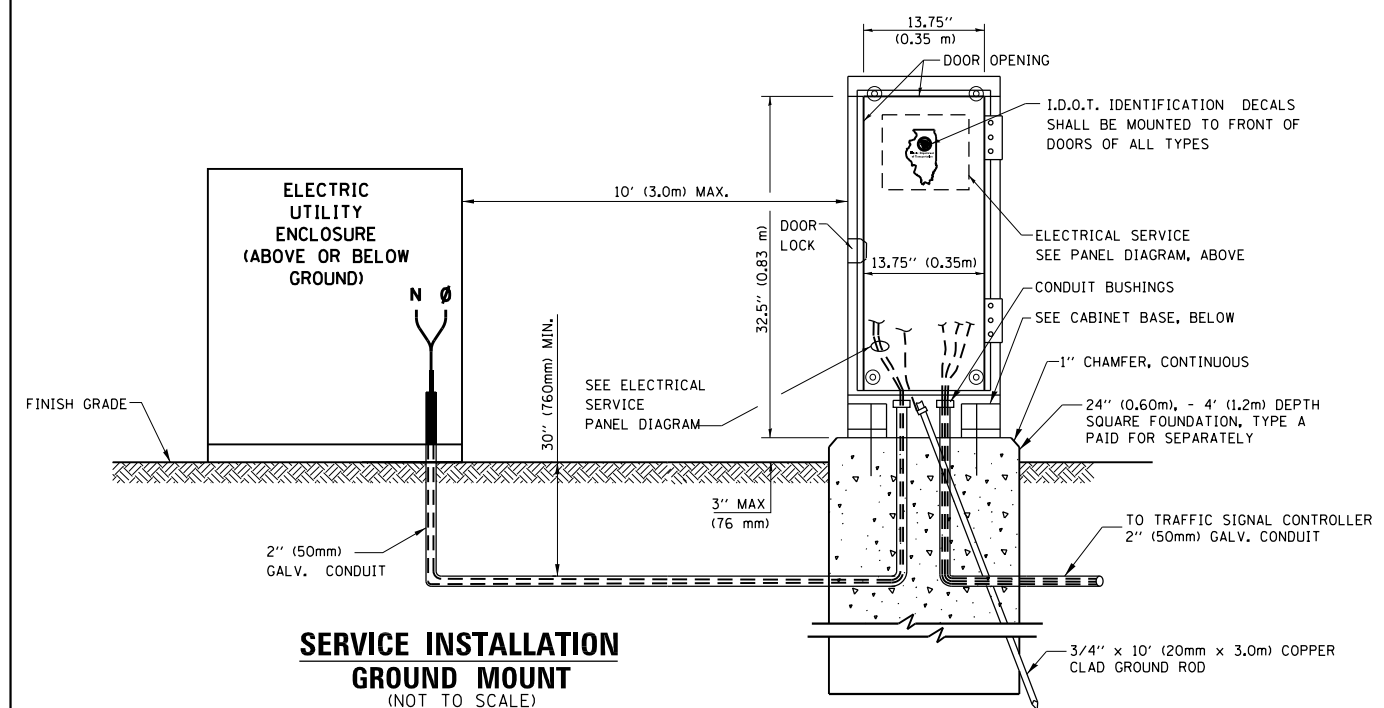

**SERVICE INSTALLATION GROUND MOUNT**  
 (NOT TO SCALE)

**CABINET - BASE BOLT PATTERN**  
 (NOT TO SCALE)

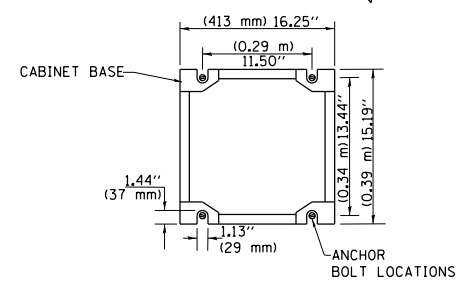

- NOTES:**
1. ELECTRIC SERVICE PANELS SHALL BE CONSTRUCTED TO U.L. STD 508, INDUSTRIAL CONTROL PANEL, AND CARRY THE U.L. LABEL.
  2. ALL WIRING SHALL BE NEATLY DRESSED AND SUPPORTED.

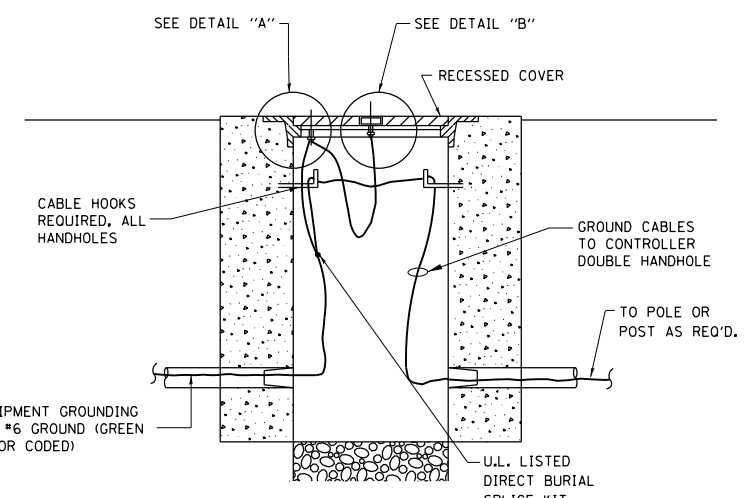
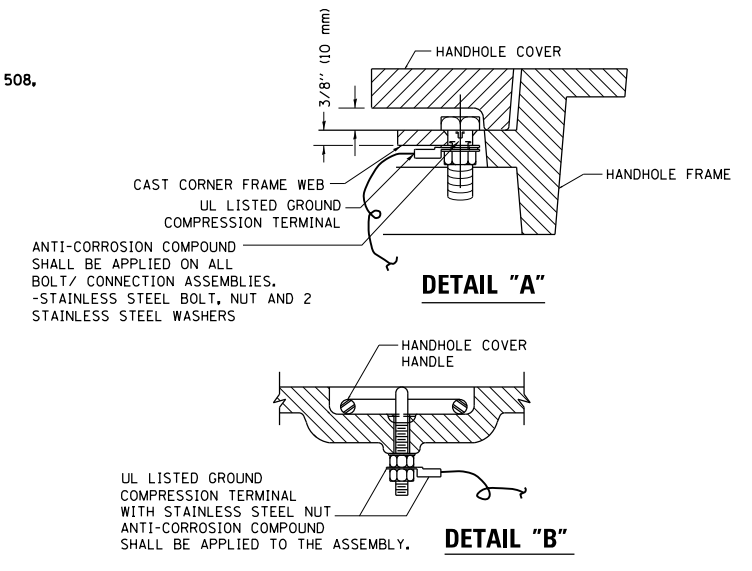

**HANDHOLE COVER & FRAME - GROUNDING DETAIL**  
 (NOT TO SCALE)

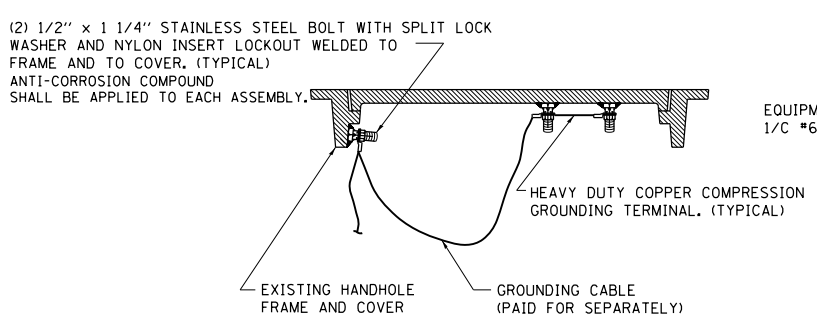

**EXISTING HANDHOLE COVER & FRAME - GROUNDING DETAIL**  
 (NOT TO SCALE)

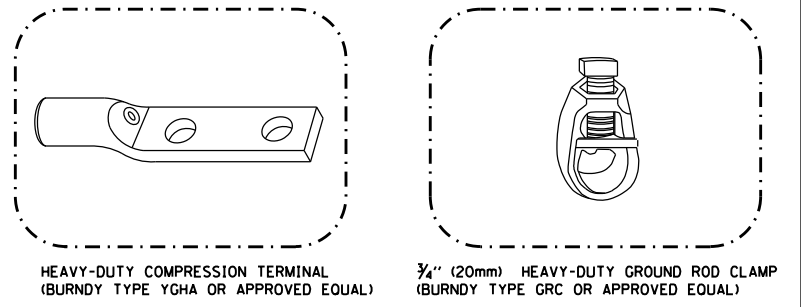

- NOTES:**
- ALL CLAMPS SHALL BE BRONZE OR COPPER, UL APPROVED.
  - GROUND CABLE SHALL BE LOOPED OVER HOOKS IN THE HANDHOLES 6.5' (2.0m) SLACK SHALL BE PROVIDED IN SINGLE HANDHOLES 13' (4.0m) OF SLACK SHALL BE PROVIDED IN DOUBLE HANDHOLES. 5' (1.4m) OF SLACK SHALL BE PROVIDED BETWEEN FRAME AND COVER.

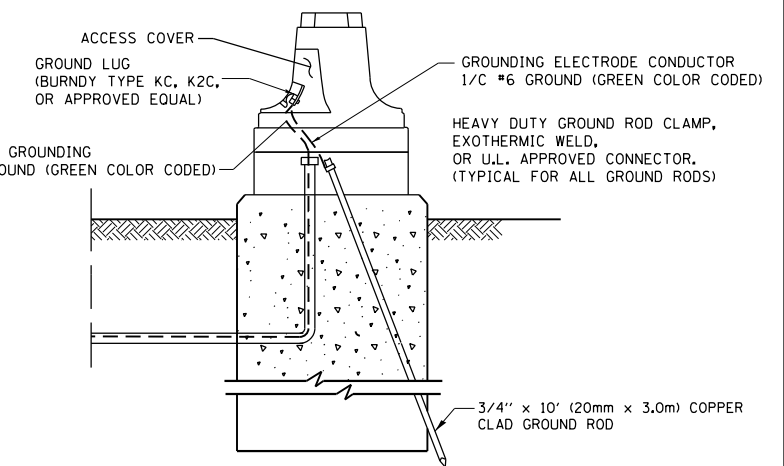

**MAST ARM POLE / POST-GROUNDING DETAIL**  
 (NOT TO SCALE)

FILE NAME =	USER NAME = hamptoncd	DESIGNED - DAD	REVISED -
et:\pw\work\p1dot\hamptoncd\0345019\01std.dgn		DRAWN - BCK	REVISED -
		CHECKED - DAD	REVISED -
		DATE - 10-28-09	REVISED -

**STATE OF ILLINOIS**  
**DEPARTMENT OF TRANSPORTATION**

**DISTRICT ONE**  
**STANDARD TRAFFIC SIGNAL DESIGN DETAILS**  
 SCALE: NONE SHEET NO. 3 OF 6 SHEETS STA. TO STA.

F.A.P. RTE.	SECTION	COUNTY	TOTAL SHEETS	SHEET NO.
348	[3130(A&B) & 2324.3JRS-3	COOK	42	38
<b>TS-05</b>		<b>CONTRACT NO. 60W61</b>		
FED. ROAD DIST. NO. 1 ILLINOIS FED. AID PROJECT				