

PULLING DEVICE

PUSHING DEVICE

**PARTIAL PLANS**  
**SUGGESTED BEAM STRAIGHTENING METHODS**

Straightening force shall be maintained on all load transfer blocking during beam straightening.

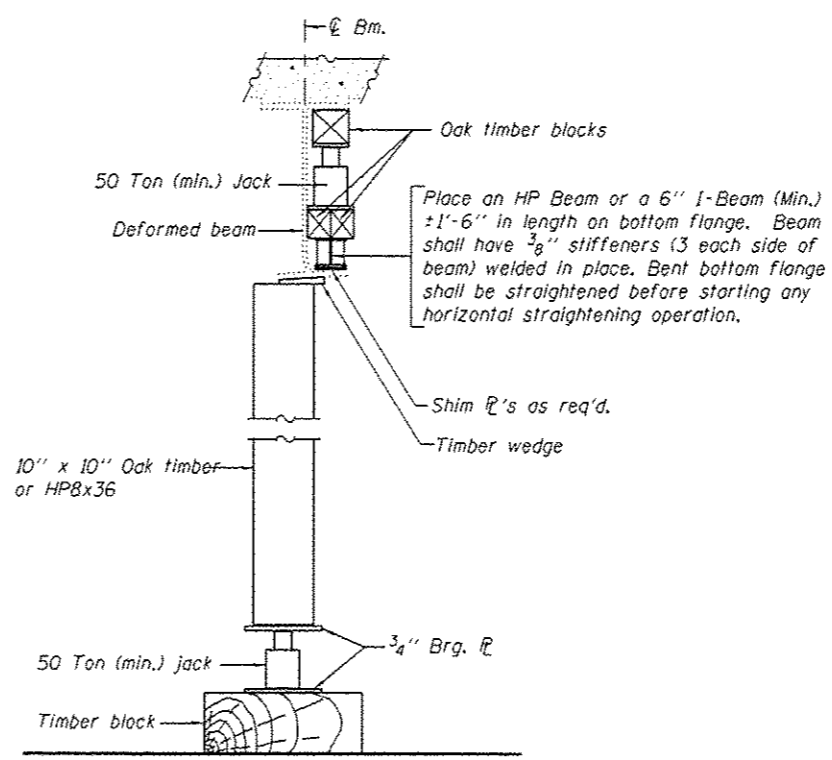

**SUGGESTED VERTICAL STRAIGHTENING DETAIL**  
(To correct flange rotation.)

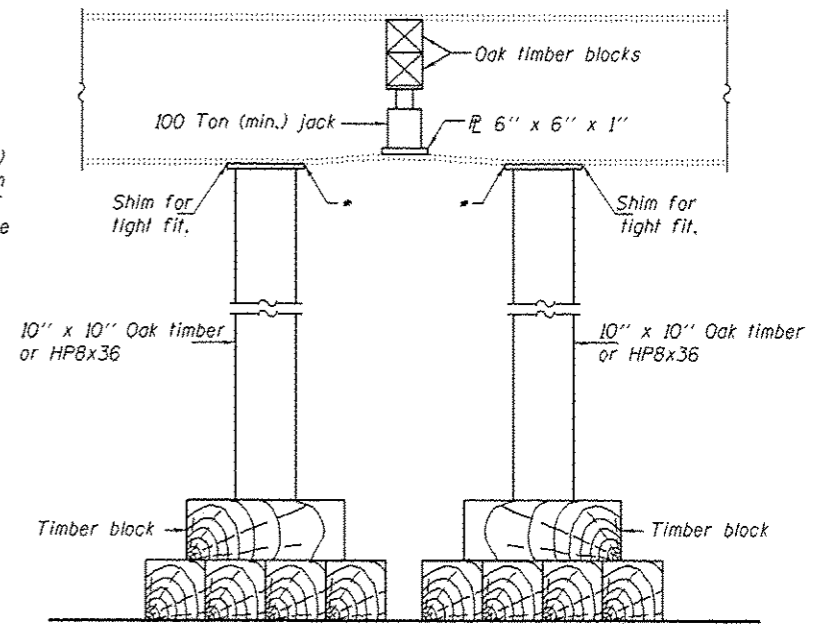

**SUGGESTED VERTICAL STRAIGHTENING DETAIL**  
(To correct localized vertical flange deformations.)

\* Edge of plate shall line up with edge of deformation.  
Note:  
Braces and jack assembly shall be placed on same side of web.  
Bent bottom flange shall be straightened before starting any horizontal straightening operations.

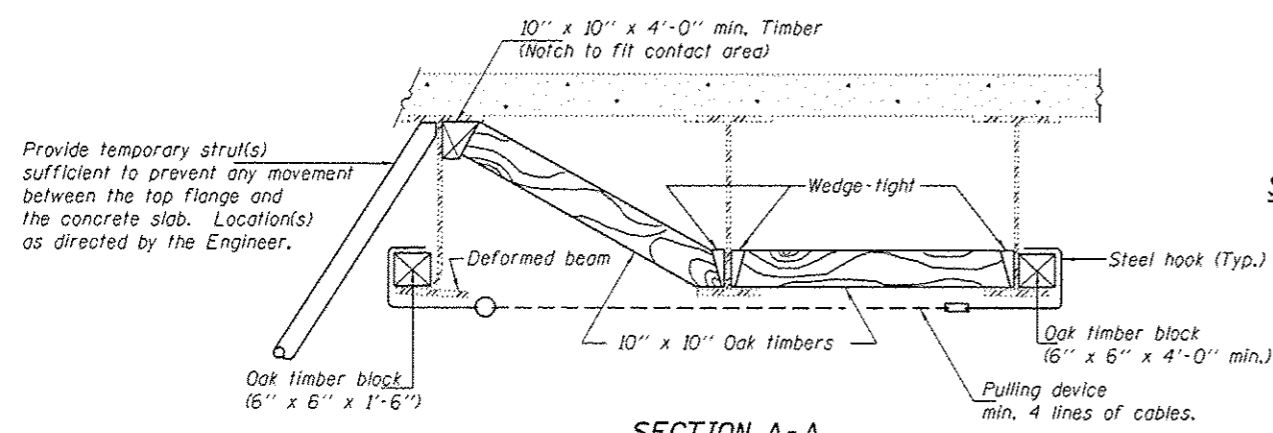

**SECTION A-A**

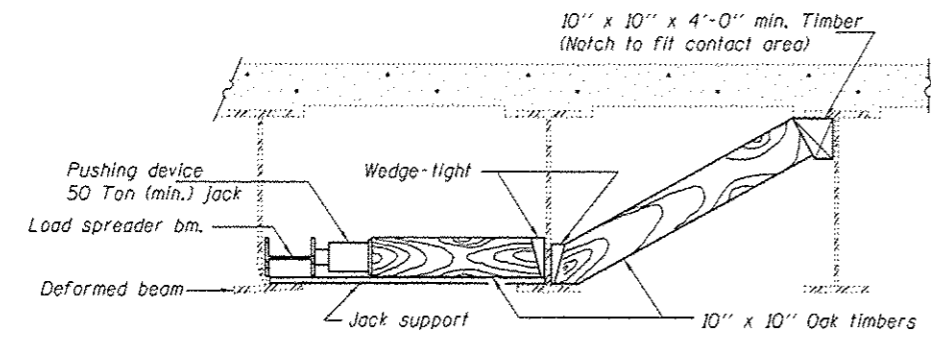

**SECTION B-B**

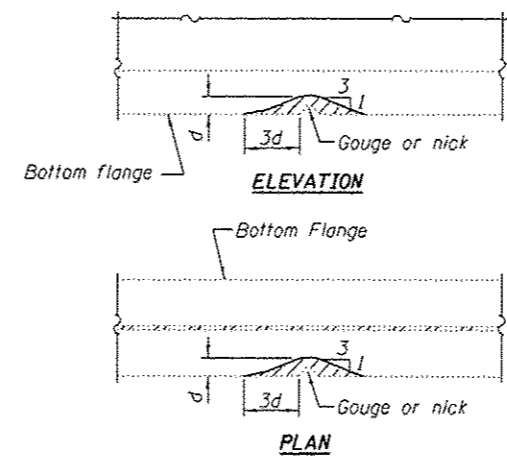

**GRINDING DETAIL**

Grind existing nicks, gouges and shallow cracks in the damaged beams as detailed. Ground surfaces shall be inspected for cracks using magnetic particle testing prior to initiating any beam straightening operations. Any cracks that cannot be removed by grinding approximately 1/4" deep shall be identified and reported to the Bureau of Bridges and Structures for further disposition. Ground surfaces shall be spot cleaned and painted with an aluminum epoxy mastic primer followed by a finish coat to match the color of the existing beam. Cost of grinding, testing and spot painting included with Beam Straightening.

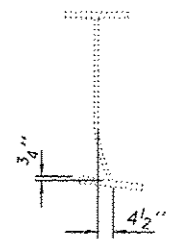

**EXISTING DEFORMATION TO BE STRAIGHTENED**  
(Looking East)  
(Approximate max. deflections)  
Deflected length of beam to be straightened is approximately 24'.

REP-11-14-2005

DESIGNED	GGE
CHECKED	SMR
DRAWN	baliva
CHECKED	GGE SMR

EXAMINED	<i>Timothy A. ...</i>
PASSED	<i>...</i>

DATE	NOVEMBER 15, 2013
REVISED	
REVISED	

STATE OF ILLINOIS  
DEPARTMENT OF TRANSPORTATION

REPAIR DETAILS  
SN 016-0168

SHEET NO. 2 OF 2 SHEETS

F.A. RTE.	SECTION	COUNTY	TOTAL SHEETS	SHEET NO.
VAR	2013-044BR	COOK	35	11
CONTRACT NO. 60W94			ILLINOIS FED. AID PROJECT	