

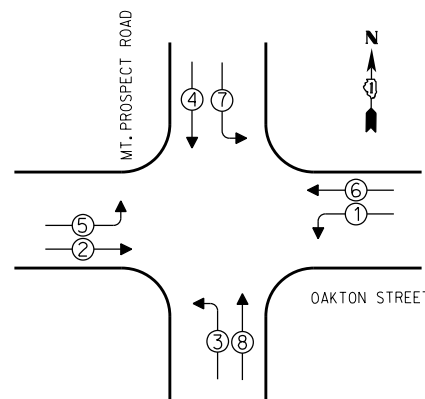

CONTROLLER SEQUENCE



- LEGEND**
- SINGLE ENTRY PHASE
 - DUAL ENTRY PHASE
 - OVERLAP
 - PEDESTRIAN PHASE
 - * NUMBER REFERS TO ASSOCIATED PHASE

EMERGENCY VEHICLE PREEMPTION SEQUENCE

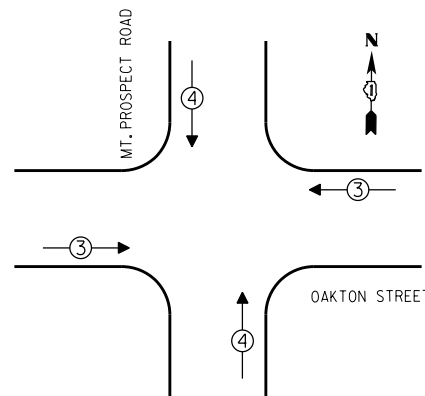

| EMERGENCY VEHICLE PREEMPTORS | | |
|------------------------------|---|---|
| EMERGENCY VEHICLE PREEMPTOR | 3 | 4 |
| MOVEMENT | ↔ | ↕ |

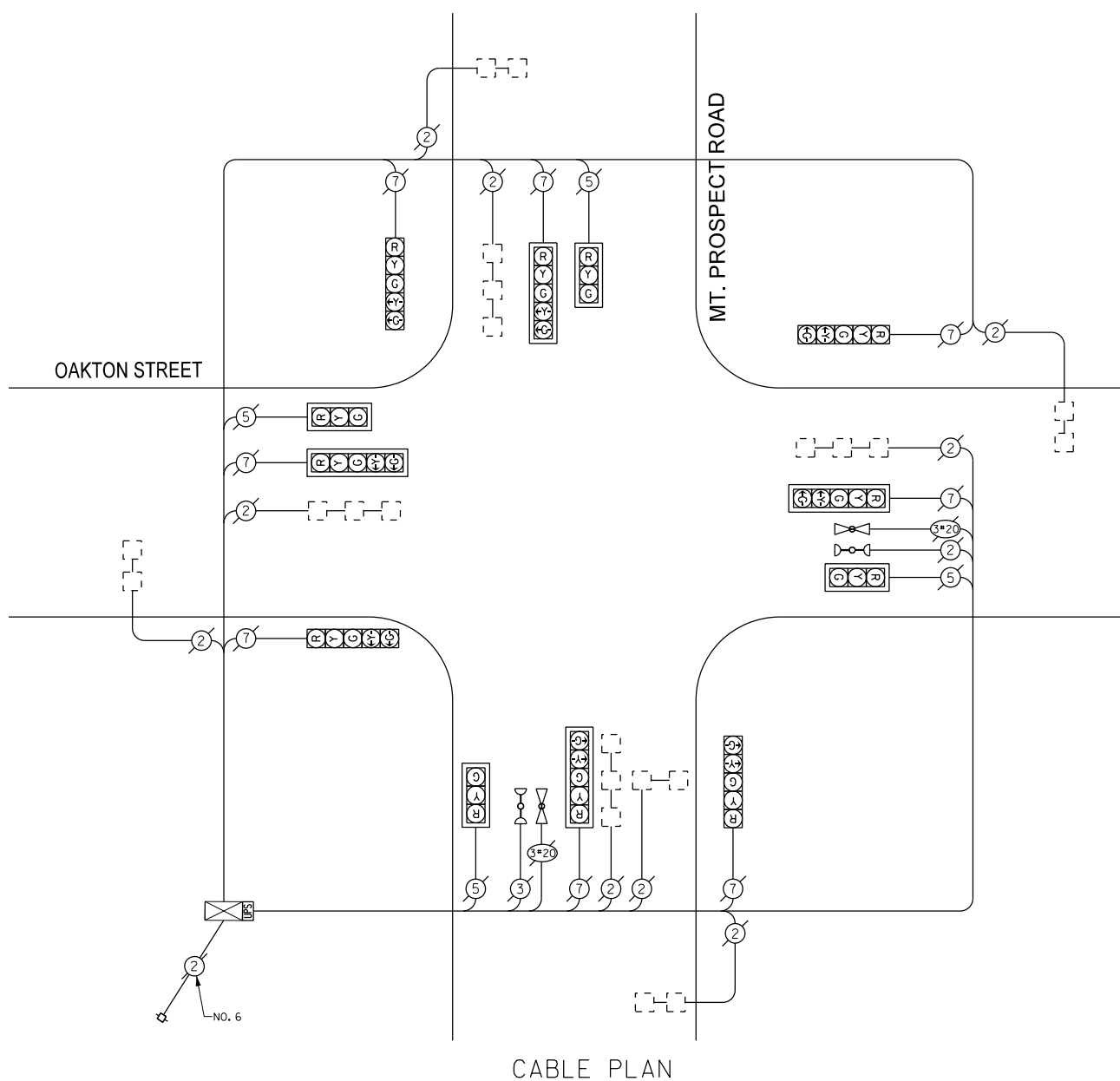

THE TRAFFIC SIGNAL CONTROL EQUIPMENT FOR THIS PROJECT SHALL BE "ECONOLITE".

CABLE PLAN

| I. D. O. T. TRAFFIC SIGNAL INSTALLATION ELECTRICAL SERVICE REQUIREMENTS | | | | | TOTAL WATTAGE |
|---|--------------|--------|------------------|---------|------------------|
| TYPE | NO. OF LAMPS | INCAND | LED % OPERATIONS | WATTAGE | |
| SIGNAL (RED) | 12 | | 17 | 0.50 | 102.00 |
| (YELLOW) | 12 | | 25 | 0.25 | 75.00 |
| (GREEN) | 12 | | 15 | 0.25 | 45.00 |
| ARROW | 16 | | 12 | 0.10 | 19.20 |
| PED. SIGNAL | | | 25 | 1.00 | |
| CONTROLLER | 1 | | 100 | 1.00 | 100.00 |
| ILLUM. SIGN | | | 25 | 0.05 | |
| LUMINAIRE | | 250 | | 0.50 | |
| VIDEO SYSTEM | | 150 | | 1.00 | |
| FLASHER | | | | 0.50 | |
| ENERGY COSTS TO: | | | | TOTAL = | 341.20 |

VILLAGE OF DES PLAINES
1420 MINER STREET
DES PLAINES, ILLINOIS 60016

ENERGY SUPPLY - CONTACT: DAVE SCHACHT
PHONE: (630) 437-2129
COMPANY:

SCHEDULE OF QUANTITIES

| QUAN. | UNIT | ITEM |
|-------|------|---|
| 1 | EACH | MAINTENANCE OF EXISTING TRAFFIC SIGNAL INSTALLATION |
| 1 | EACH | MODIFY EXISTING CONTROLLER CABINET |
| 1 | EACH | UNINTERRUPTIBLE POWER SUPPLY, SPECIAL |

| | |
|-----------------|-----------|
| DESIGNED - JAM | REVISED - |
| DRAWN - JAM | REVISED - |
| CHECKED - LMM | REVISED - |
| DATE - 10-14-13 | REVISED - |

STATE OF ILLINOIS
DEPARTMENT OF TRANSPORTATION

SCHEDULE OF QUANTITIES, CABLE PLAN, PHASE DESIGNATION
DIAGRAM, AND EMERGENCY VEHICLE PREEMPTION SEQUENCE,
OAKTON STREET AT MT. PROSPECT ROAD

SCALE: NONE SHEET OF SHEETS STA. TO STA.

| F.A. RTE. | SECTION | COUNTY | TOTAL SHEETS | SHEET NO. |
|---------------------------|------------|--------|--------------|--------------------|
| VAR | 2013-054TS | COOK | 99 | 53 |
| | | | | CONTRACT NO. 60X15 |
| ILLINOIS FED. AID PROJECT | | | | |

**SAM SCHWARTZ
ENGINEERING**
3100 W. HIGGINS, STE. 100, HOFFMAN ESTATES, IL 60169