

LEGEND
 - [Symbol] SINGLE ENTRY PHASE
 - [Symbol] DUAL ENTRY PHASE
 - [Symbol] OVERLAP
 - [Symbol] PEDESTRIAN PHASE
 * NUMBER REFERS TO ASSOCIATED PHASE

PHASE DESIGNATION DIAGRAM

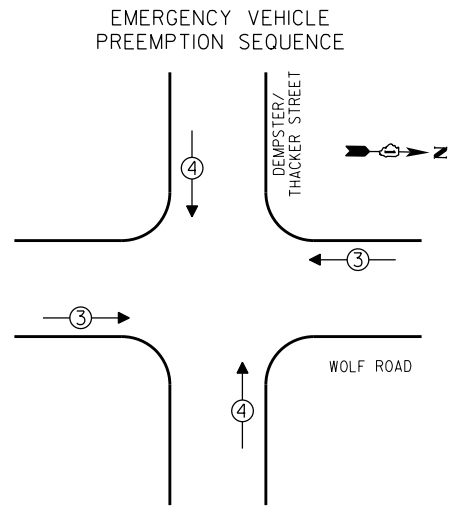

EMERGENCY VEHICLE PREEMPTORS		
EMERGENCY VEHICLE PREEMPTOR	3	4
MOVEMENT	↔	↕

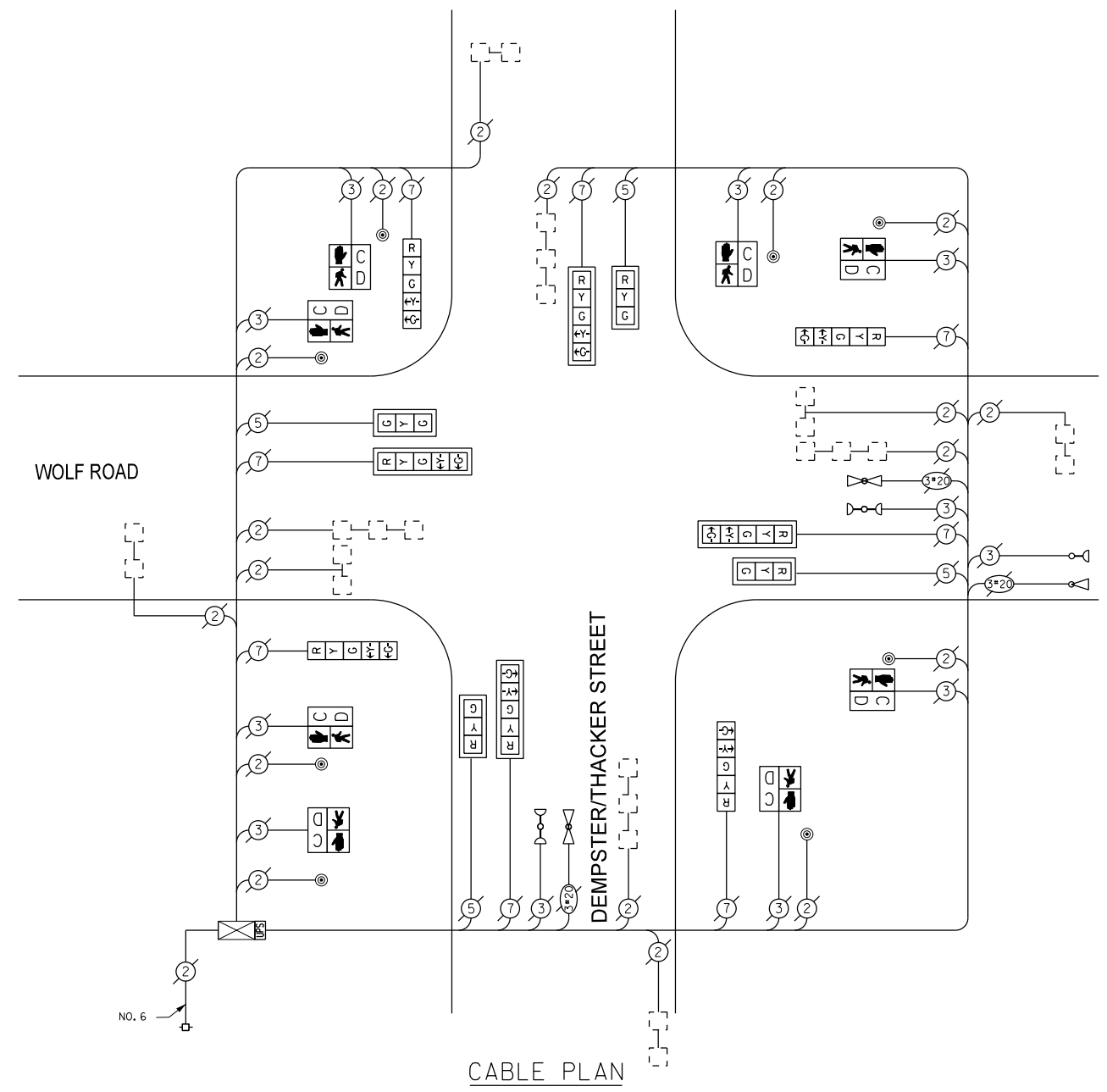

CABLE PLAN

RETROFIT ALL EXISTING TRAFFIC SIGNAL HEADS

THE TRAFFIC SIGNAL CONTROL EQUIPMENT FOR THIS PROJECT SHALL BE "EAGLE".

I. D. O. T. TRAFFIC SIGNAL INSTALLATION ELECTRICAL SERVICE REQUIREMENTS					TOTAL WATTAGE
TYPE	NO. OF LAMPS	INCAND	LED % OPERATIONS		
SIGNAL (RED)	12		17	0.50	102.00
(YELLOW)	12		25	0.25	75.00
(GREEN)	12		15	0.25	45.00
ARROW	16		12	0.10	19.20
PED. SIGNAL	8		25	1.00	200.00
CONTROLLER	1		100	1.00	100.00
ILLUM. SIGN			25	0.05	
LUMINAIRE		250		0.50	
VIDEO SYSTEM		150		1.00	
FLASHER				0.50	
ENERGY COSTS TO:				TOTAL =	541.20

VILLAGE OF DES PLAINES
 1420 MINER STREET
 DES PLAINES, ILLINOIS 60016

ENERGY SUPPLY - CONTACT: DAVE SCHACHT
 PHONE: (630) 437-2129
 COMPANY:

REMOVE EXISTING TRAFFIC SIGNAL EQUIPMENT

THE FOLLOWING ITEMS SHALL BE REMOVED BY THE CONTRACTOR AND SHALL BE DISPOSED OF BY THEM OUTSIDE THE RIGHT-OF-WAY AT THEIR EXPENSE. THE SALVAGE VALUE OF THE REMOVED EQUIPMENT SHALL BE REFLECTED IN THE CONTRACT BID PRICE.

QUANTITY	UNIT	DESCRIPTION
8	EACH	PEDESTRIAN SIGNAL HEAD, I-FACE
8	EACH	PEDESTRIAN PUSHBUTTON

SCHEDULE OF QUANTITIES

QUAN.	UNIT	ITEM
1	EACH	MAINTENANCE OF EXISTING TRAFFIC SIGNAL INSTALLATION
8	EACH	PEDESTRIAN SIGNAL HEAD, LED, I-FACE, BRACKET MOUNTED WITH COUNTDOWN TIMER
8	EACH	PEDESTRIAN PUSH-BUTTON
1	EACH	MODIFY EXISTING CONTROLLER CABINET
1	EACH	REMOVE EXISTING TRAFFIC SIGNAL EQUIPMENT
1	EACH	UNINTERRUPTIBLE POWER SUPPLY, SPECIAL
4	EACH	SIGNAL HEAD, LED, I-FACE, 3-SECTION, MAST ARM MOUNTED, RETROFIT
4	EACH	SIGNAL HEAD, LED, I-FACE, 5-SECTION, MAST ARM MOUNTED, RETROFIT
4	EACH	SIGNAL HEAD, LED, I-FACE, 5-SECTION, BRACKET MOUNTED, RETROFIT

SAM SCHWARTZ ENGINEERING
 3100 W. HIGGINS, STE. 100, HOFFMAN ESTATES, IL 60169

DESIGNED - JAM	REVISED -
DRAWN - JAM	REVISED -
CHECKED - LMM	REVISED -
DATE - 10-14-13	REVISED -

STATE OF ILLINOIS DEPARTMENT OF TRANSPORTATION

SCHEDULE OF QUANTITIES, CABLE PLAN, PHASE DESIGNATION DIAGRAM, AND EMERGENCY VEHICLE PREEMPTION SEQUENCE, WOLF ROAD AND DEMPSTER/THACKER STREET

SCALE: NONE SHEET OF SHEETS STA. TO STA.

F.A. RTE.	SECTION	COUNTY	TOTAL SHEETS	SHEET NO.
VAR	2013-054TS	COOK	99	64
CONTRACT NO. 60X15				
ILLINOIS FED. AID PROJECT				