

BY: DATE: SURVEYED: GRADES CHECKED: ILL. NOTED: STRUCTURE: NOTATIONS: OK/KO

BY: DATE: SURVEYED: GRADES CHECKED: ILL. NOTED: STRUCTURE: NOTATIONS: OK/KO

PLAN: NOTE BOOK NO. SURVEYED: ALIGNED: CHECKED: RT. OF WAY CHECKED: ADD. FILE NAME:

ENGINEERING LTD. CHRISTOPHER B. BURKE 3575 West Higgins Road, Suite 600 Rosemont, Illinois 60018 (647) 923-5500

EXISTING CONTROLLER SEQUENCE

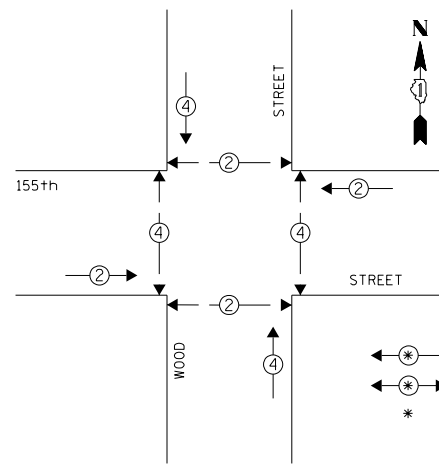

LEGEND  
 ←\*→ DUAL ENTRY PHASE  
 ←\* PEDESTRIAN PHASE  
 \* NUMBER REFERS TO ASSOCIATED PHASE

PHASE DESIGNATION DIAGRAM

EMERGENCY VEHICLE PREEMPTION SEQUENCE

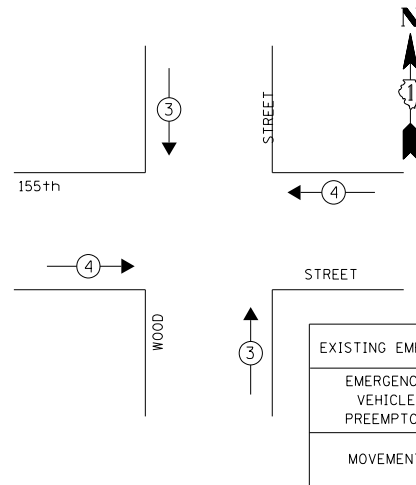

REMOVAL OF EXISTING TRAFFIC SIGNAL EQUIPMENT

THE FOLLOWING ITEMS SHALL BE REMOVED BY THE CONTRACTOR AND SHALL BE DISPOSED OF BY THEM OUTSIDE THE RIGHT-OF-WAY AT THEIR EXPENSE. THE SALVAGE VALUE OF THE REMOVED EQUIPMENT SHALL BE REFLECTED IN THE CONTRACT BID PRICE.

- 4 EACH SIGNAL HEAD, 2-FACE, 3-SECTION
- 4 EACH SIGNAL HEAD, 1-FACE, 3-SECTION
- 8 EACH PEDESTRIAN SIGNAL HEAD, 1-FACE
- 8 EACH PEDESTRIAN PUSH-BUTTON
- 2 EACH STEEL POST

CONSTRUCTION NOTE:

- ① THE CONTRACTOR SHALL REPLACE THE EXISTING TRAFFIC SIGNAL POST WITH THE PROPOSED TRAFFIC SIGNAL POST, 14 FT. AND ATTACH THE PROPOSED POST TO THE EXISTING FOUNDATION.

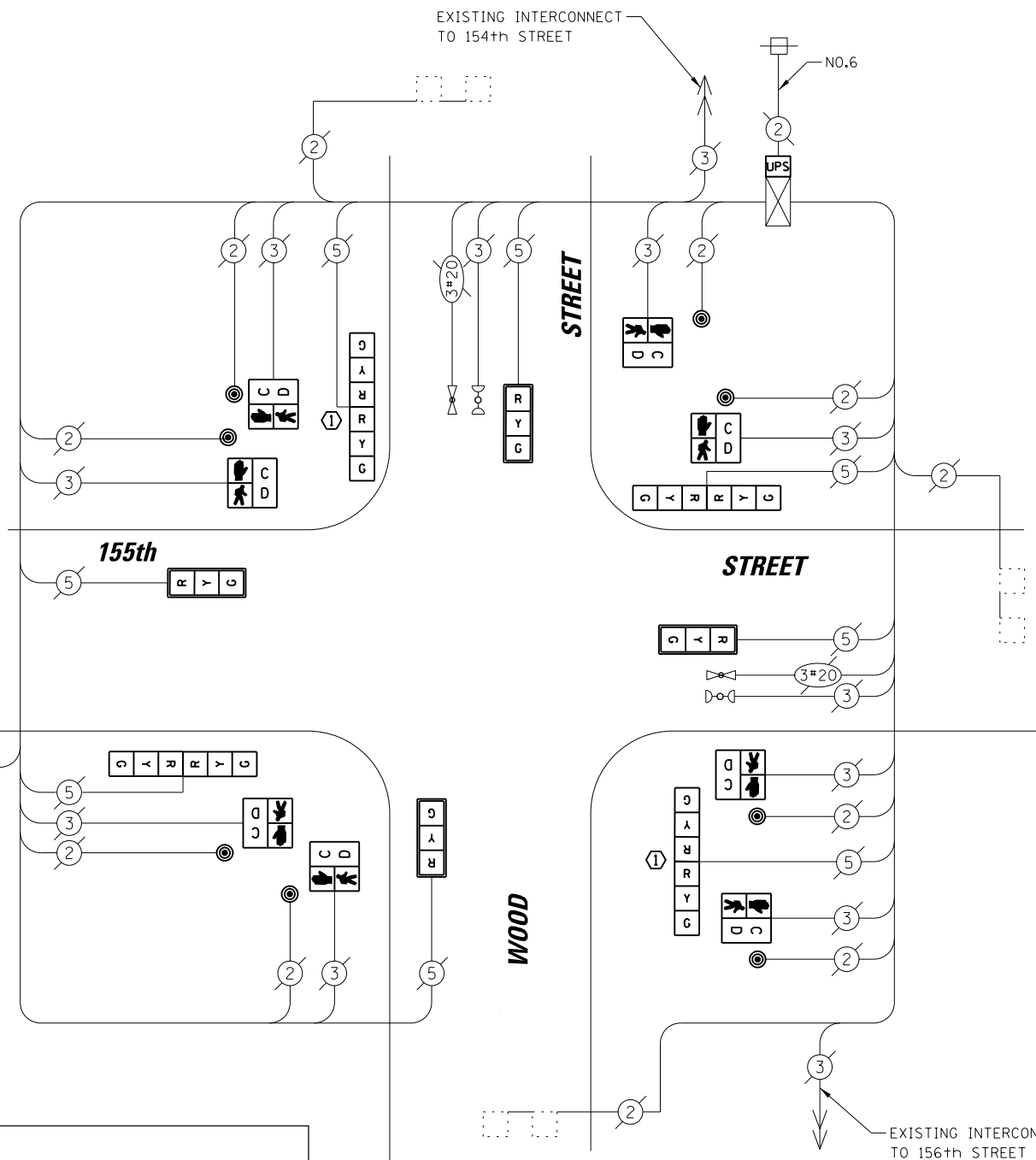

CABLE PLAN

NOTES

- 1) ALL COSTS RELATED TO ATTACHING THE POSTS TO THE EXISTING FOUNDATION SHALL BE INCLUDED IN THE UNIT COST OF TRAFFIC SIGNAL POST OF THE SIZE SPECIFIED
- 2) PRIOR TO REMOVING ANY TRAFFIC SIGNAL POST SPECIFIED TO BE REPLACED IN THE SAME LOCATION, THE CONTRACTOR SHALL VERIFY THAT THE PATTERN, SPACING, AND CONDITION OF THE EXISTING BOLTS ARE SUITABLE FOR RE-USE WITH A NEW POST. IF THE BOLTS ARE NOT REUSABLE, REPLACE AS DIRECTED BY THE ENGINEER.
- 3) THE CONTRACTOR SHALL RELOCATE EXISTING SIGN PANELS FROM POSTS THAT ARE INDICATED FOR REPLACEMENT TO THE NEW POSTS AS SHOWN ON THE PLANS OR AS DIRECTED BY THE ENGINEER. THE COST OF REMOVAL, RELOCATION AND ANY NEW MOUNTING HARDWARE NECESSARY TO COMPLETE THIS WORK SHALL BE INCLUDED IN THE UNIT COST OF TRAFFIC SIGNAL POST OF THE SIZE SPECIFIED.

SCHEDULE OF QUANTITIES

ITEM	UNIT	QUANTITY
MAINTENANCE OF EXISTING TRAFFIC SIGNAL INSTALLATION	EACH	1
TRAFFIC SIGNAL POST, GALVANIZED STEEL 14 FT.	EACH	2
SIGNAL HEAD, LED, 1-FACE, 3-SECTION, MAST-ARM MOUNTED	EACH	4
SIGNAL HEAD, LED, 2-FACE, 3-SECTION, BRACKET MOUNTED	EACH	4
PEDESTRIAN SIGNAL HEAD, LED, 1-FACE, BRACKET MOUNTED WITH COUNTDOWN TIMER	EACH	8
TRAFFIC SIGNAL BACKPLATE, LOUVERED, ALUMINUM	EACH	4
PEDESTRIAN PUSH-BUTTON	EACH	8
MODIFY EXISTING CONTROLLER CABINET	EACH	1
REMOVE EXISTING TRAFFIC SIGNAL EQUIPMENT	EACH	1
UNINTERRUPTABLE POWER SUPPLY, SPECIAL	EACH	1

I.D.O.T. TRAFFIC SIGNAL INSTALLATION ELECTRICAL SERVICE REQUIREMENTS					TOTAL WATTAGE
TYPE	NO. OF LAMPS	WATTAGE INCAND.	LED	% OPERATION	
SIGNAL (RED)	12		17	0.50	102.00
(YELLOW)	12		25	0.25	75.00
(GREEN)	12		15	0.25	45.00
ARROW	-		12	0.10	-
PED. SIGNAL	8		25	1.00	200.00
CONTROLLER	1		100	1.00	100.00
ILLUMINATED SIGN	-		25	0.05	-
VIDEO SYSTEM	-		150	1.00	-
LUMINAIRE	-	250		0.50	-
BATTERY BACKUP	1	25		1.00	25.0
FLASHER				0.50	-
ENERGY COSTS TO:					TOTAL = 547.00

CITY OF HARVEY

15320 BROADWAY AVENUE  
 HARVEY, IL 60426

ENERGY SUPPLY: CONTACT: BRAD SHINABARGAR  
 PHONE: (708)-235-2692  
 COMPANY: COMED

FILE NAME = N:\dot\130116\Work Order 13019 - South Cook County LED\Traffic\CAB_155th-Wood.L.sh	USER NAME = fpaceone	DESIGNED - EAJ	REVISED -
		DRAWN - FPB / FCP	REVISED -
		CHECKED - GMZ	REVISED -
		DATE - SEPT. , 2013	REVISED -

STATE OF ILLINOIS  
 DEPARTMENT OF TRANSPORTATION

SCHEDULE OF QUANTITIES, CABLE PLAN, PHASE DESIGNATION DIAGRAM AND EMERGENCY VEHICLE PREEMPTION SEQUENCE  
 155TH STREET AT WOOD STREET

SCALE: SHEET NO. OF SHEETS STA. TO STA.

F.A.P. RTE.	SECTION	COUNTY	TOTAL SHEETS	SHEET NO.
	VARIOUS	COOK	87	56
FED. ROAD DIST. NO. ILLINOIS FED. AID PROJECT			CONTRACT NO. 60X24	

TS # 13805  
 HARVEY