

BY: \_\_\_\_\_ DATE: \_\_\_\_\_  
 SURVEYED \_\_\_\_\_  
 ALIGNED \_\_\_\_\_  
 RT. OF WAY CHECKED \_\_\_\_\_  
 ADD. FILE NAME \_\_\_\_\_

PLAN NO. \_\_\_\_\_  
 NOTE BOOK NO. \_\_\_\_\_

ENGINEERING LTD.  
**CHRISTOPHER B. BURKE**  
 9575 West Higgins Road, Suite 600  
 Rosemont, Illinois 60018  
 (617) 823-5500

DATE: \_\_\_\_\_  
 BY: \_\_\_\_\_  
 SURVEYED \_\_\_\_\_  
 GRADES CHECKED \_\_\_\_\_  
 ELEM. NOTED \_\_\_\_\_  
 STRUCTURE NOTATIONS OKWD

PROFILE NO. \_\_\_\_\_  
 NOTE BOOK NO. \_\_\_\_\_

EXISTING CONTROLLER SEQUENCE IV

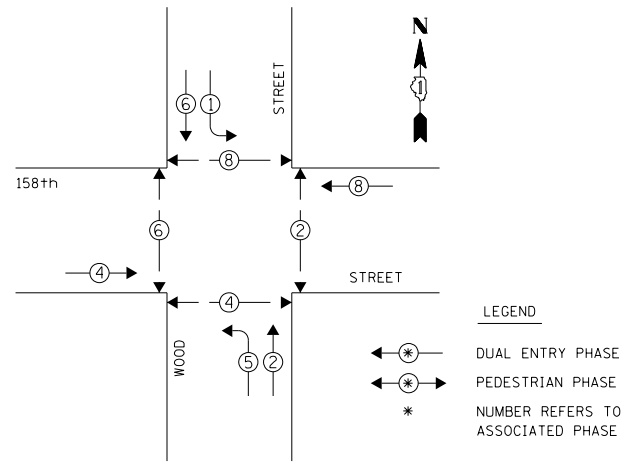

PHASE DESIGNATION DIAGRAM

EXISTING EMERGENCY VEHICLE PREEMPTION SEQUENCE

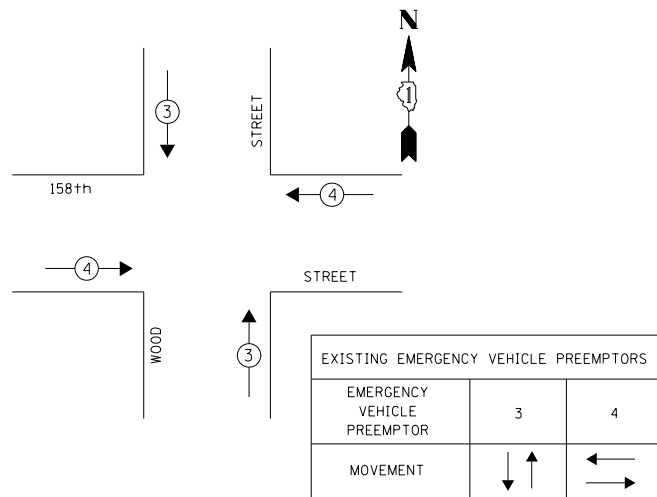

I.D.O.T. TRAFFIC SIGNAL INSTALLATION ELECTRICAL SERVICE REQUIREMENTS					TOTAL WATTAGE
TYPE	NO. OF LAMPS	WATTAGE X INCAND.	LED	% OPERATION	
SIGNAL (RED)	10		17	0.50	85.00
(YELLOW)	10		25	0.25	62.50
(GREEN)	10		15	0.25	37.50
ARROW	4		12	0.10	4.80
PED. SIGNAL	8		25	1.00	200.00
CONTROLLER	1		100	1.00	100.00
ILLUMINATED SIGN	-		25	0.05	-
VIDEO SYSTEM	-		150	1.00	-
LUMINAIRE	-	250		0.50	-
BATTERY BACKUP	1	25		1.00	25.0
FLASHER				0.50	
ENERGY COSTS TO:				TOTAL =	514.80

CITY OF HARVEY

15320 BROADWAY AVENUE  
 HARVEY, IL 60426

ENERGY SUPPLY: CONTACT: **BRAD SHINABARGAR**  
 PHONE: (708)-235-2692  
 COMPANY: **COMED**

REMOVAL OF EXISTING TRAFFIC SIGNAL EQUIPMENT

THE FOLLOWING ITEMS SHALL BE REMOVED BY THE CONTRACTOR AND SHALL BE DISPOSED OF BY THEM OUTSIDE THE RIGHT-OF-WAY AT THEIR EXPENSE. THE SALVAGE VALUE OF THE REMOVED EQUIPMENT SHALL BE REFLECTED IN THE CONTRACT BID PRICE.

- 1 EACH PEDESTRIAN SIGNAL HEAD, 2-FACE
- 6 EACH PEDESTRIAN SIGNAL HEAD, 1-FACE
- 7 EACH PEDESTRIAN PUSH-BUTTON

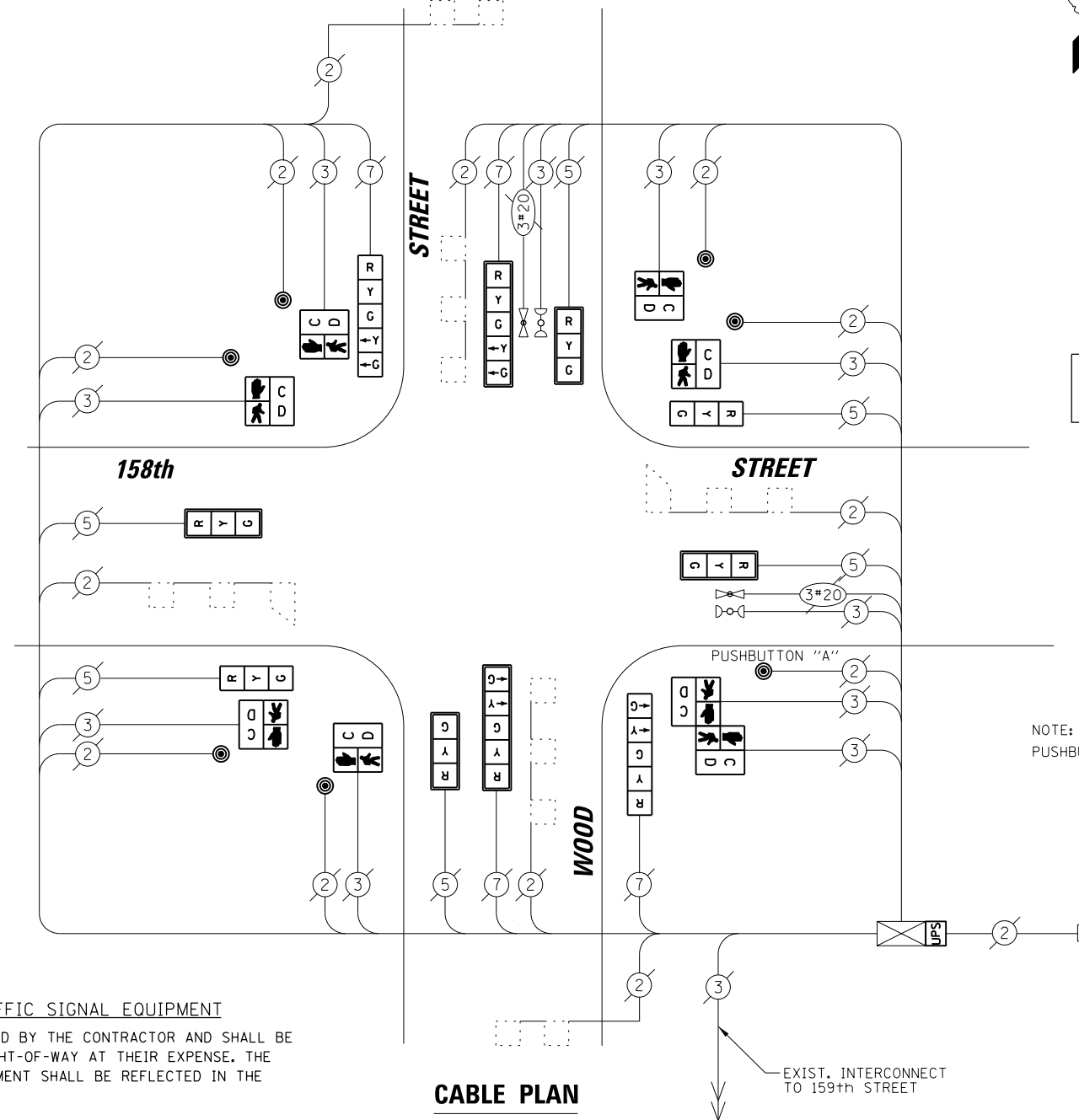

CABLE PLAN

SCHEDULE OF QUANTITIES

ITEM	UNIT	QUANTITY
MAINTENANCE OF EXISTING TRAFFIC SIGNAL INSTALLATION	EACH	1
PEDESTRIAN SIGNAL HEAD, LED, 1-FACE, BRACKET MOUNTED WITH COUNTDOWN TIMER	EACH	6
PEDESTRIAN SIGNAL HEAD, LED, 2-FACE, BRACKET MOUNTED WITH COUNTDOWN TIMER	EACH	1
MODIFY EXISTING CONTROLLER CABINET	EACH	1
REMOVE EXISTING TRAFFIC SIGNAL EQUIPMENT	EACH	1
UNINTERRUPTABLE POWER SUPPLY, SPECIAL	EACH	1
SIGNAL HEAD, LED, 1-FACE, 3-SECTION, BRACKET MOUNTED, RETROFIT	EACH	2
SIGNAL HEAD, LED, 1-FACE, 3-SECTION, MAST ARM MOUNTED, RETROFIT	EACH	4
SIGNAL HEAD, LED, 1-FACE, 5-SECTION, MAST ARM MOUNTED, RETROFIT	EACH	2
SIGNAL HEAD, LED, 1-FACE, 5-SECTION, BRACKET MOUNTED, RETROFIT	EACH	2
PEDESTRIAN PUSH-BUTTON, NON-LATCHING	EACH	7

RETROFIT ALL EXISTING SIGNAL HEADS TO L.E.D.

NOTE: PUSHBUTTON "A" SHALL PLACE A CALL IN PHASES 2 AND 4.

FILE NAME = N:\dot\130116\Work Order 13019 - South Cook County LED\Traffic\CAB_158th-Wood.L.sht	USER NAME = fpaceone	DESIGNED - EAJ	REVISED -
		DRAWN - FPB / FCP	REVISED -
		CHECKED - GMZ	REVISED -
		DATE - SEPT. , 2013	REVISED -

STATE OF ILLINOIS  
 DEPARTMENT OF TRANSPORTATION

SCHEDULE OF QUANTITIES, CABLE PLAN, PHASE DESIGNATION DIAGRAM AND EMERGENCY VEHICLE PREEMPTION SEQUENCE  
 158TH STREET AT WOOD STREET

SCALE: SHEET NO. OF SHEETS STA. TO STA.

F.A.P. RTE.	SECTION	COUNTY	TOTAL SHEETS	SHEET NO.
	VARIOUS	COOK	87	58
CONTRACT NO. 60X24				
FED. ROAD DIST. NO. ILLINOIS FED. AID PROJECT				

TS # 13815  
 HARVEY