

INDEX OF SHEETS

FOR INDEX OF SHEETS, SEE SHEET NO. 2

PROJECT LOCATED IN VILLAGE OF SKOKIE

TRAFFIC DATA:

	ADT (2030)	DESIGN SPEED	POSTED SPEED
CRAWFORD AVENUE	21,000	40 MPH	35 MPH
CHURCH STREET	12,800	35 MPH	30 MPH

DESIGN DESIGNATION

CRAWFORD AVENUE = MINOR ARTERIAL
 CHURCH STREET = MAJOR COLLECTOR

**STATE OF ILLINOIS
 DEPARTMENT OF TRANSPORTATION
 DIVISION OF HIGHWAYS**

**PROPOSED PLANS
 FOR FEDERAL AID HIGHWAY**

**FAU ROUTE 1313 (CHURCH STREET)
 AT FAU ROUTE 2812 (CRAWFORD AVENUE)
 INTERSECTION CHANNELIZATION AND TRAFFIC SIGNAL REPLACEMENT
 SECTION 00-00241-00-CH
 PROJECT M-8003(802)
 VILLAGE OF SKOKIE
 COOK COUNTY
 C-91-192-07**

F.A.U. RTE.	SECTION	COUNTY	TOTAL SHEETS	SHEET NO.
1313	00-00241-00-CH	COOK	47	1
FED. ROAD DIST. NO.	ILLINOIS CONTRACT NO. 63734			

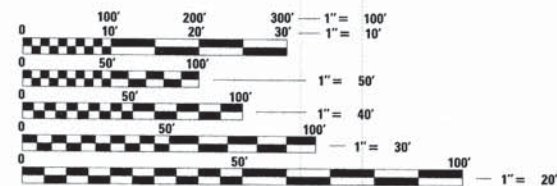
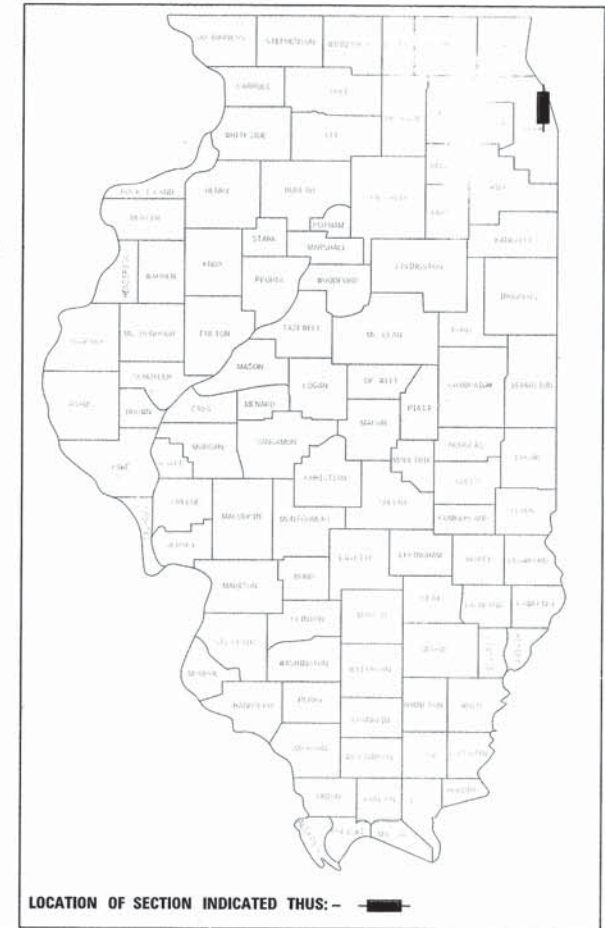

FULL SIZE PLANS HAVE BEEN PREPARED USING STANDARD ENGINEERING SCALES. REDUCED SIZED PLANS WILL NOT CONFORM TO STANDARD SCALES. IN MAKING MEASUREMENTS ON REDUCED PLANS, THE ABOVE SCALES MAY BE USED.

J.U.L.I.E.
 JOINT UTILITY LOCATION INFORMATION FOR EXCAVATION
 1-800-892-0123 OR 811

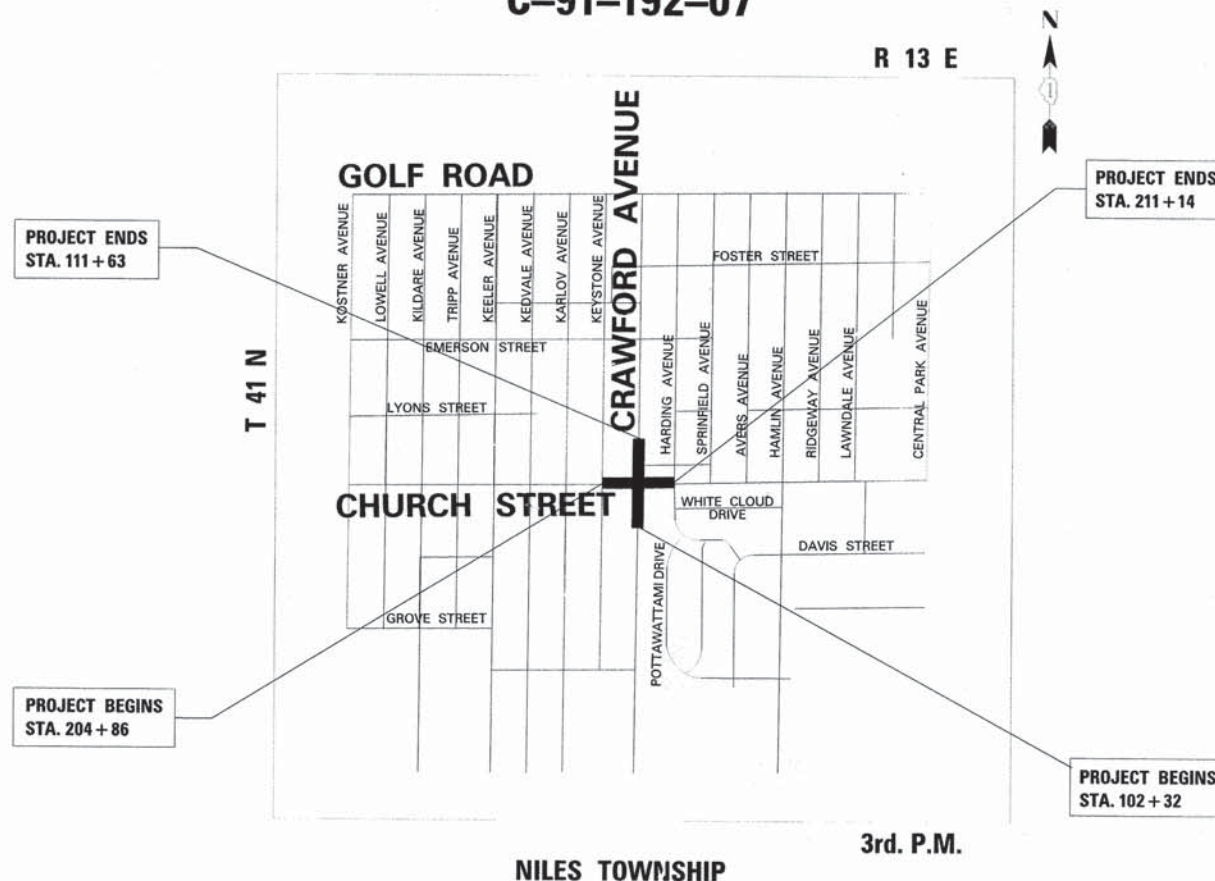

NILES TOWNSHIP

3rd. P.M.

LOCATION MAP

GROSS LENGTH OF PROJECT = 1559.00 FT. (0.30 MI.)
 NET LENGTH OF PROJECT = 1559.00 FT. (0.30 MI.)

TYLIN INTERNATIONAL
 200 SOUTH WACKER DRIVE, SUITE 1400
 CHICAGO, ILLINOIS 60606
 TEL: 312-777-2900 FAX: 312-705-0305

**STATE OF ILLINOIS
 DEPARTMENT OF TRANSPORTATION
 DIVISION OF HIGHWAYS**

APPROVED Oct 18th 20 13
Frederick B. Schattone
 VILLAGE OF SKOKIE

PASSED OCTOBER 20 20 13
C. J. Holt
 DISTRICT 1 ENGINEER OF LOCAL ROADS AND STREETS

RELEASED FOR BID
 BASED ON LIMITED
 REVIEW October 28 20 13
John Fortmann
 DEPUTY DIRECTOR OF HIGHWAYS, REGION 1 ENGINEER

**PRINTED BY THE AUTHORITY
 OF THE STATE OF ILLINOIS**

CONTRACT NO. 63734

INDEX OF IDOT STANDARDS

STANDARD NO.	TITLE
000001-06	STANDARD SYMBOLS, ABBREVIATIONS AND PATTERNS
280001-07	TEMPORARY EROSION CONTROL SYSTEMS
353001-04	PCC BASE COURSE WITH HMA BINDER AND SURFACE COURSES
420001-07	PAVEMENT JOINTS
420111-03	PCC PAVEMENT ROUNDOUTS
424006-01	DIAGONAL CURB RAMPS FOR SIDEWALKS
424011-01	CORNER PARALLEL CURB RAMPS FOR SIDEWALKS
604051-03	FRAME AND GRATE TYPE 11
604086-02	FRAME AND GRATE TYPE 23
606001-05	CONCRETE CURB TYPE B AND COMBINATION CONCRETE CURB AND GUTTER
606301-04	PC CONCRETE ISLANDS AND MEDIANS
701006-05	OFF-RD OPERATIONS, 2L, 2W, 15' (4.5 m) TO 24" (600 mm) FROM PAVEMENT EDGE
701011-04	OFF-RD MOVING OPERATIONS, 2L, 2W, DAY ONLY
701101-04	OFF-RD OPERATIONS, MULTILANE, 15' (4.5 m) TO 24" (600 mm) FROM PAVEMENT EDGE
701501-06	URBAN LANE CLOSURE, 2L, 2W, UNDIVIDED
701601-09	URBAN LANE CLOSURE, MULTILANE, 1W OR 2W WITH NONTRAVERSABLE MEDIAN
701701-09	URBAN LANE CLOSURE, MULTILANE INTERSECTION
701801-05	SIDEWALK, CORNER OR CROSSWALK CLOSURE
701901-03	TRAFFIC CONTROL DEVICES
720001-01	SIGN PANEL MOUNTING DETAILS
720006-04	SIGN PANEL ERECTION DETAILS
720011-01	METAL POSTS FOR SIGNS, MARKERS & DELINEATORS
728001-01	TELESCOPING STEEL SIGN SUPPORT
729001-01	APPLICATIONS OF TYPES A&B METAL POSTS (FOR SIGNS & MARKERS)
731001-01	BASE FOR TELESCOPING STEEL SIGN SUPPORT
780001-04	TYPICAL PAVEMENT MARKINGS
814001-02	HANDHOLES
814006-02	DOUBLE HANDHOLES
862001-01	UNINTERRUPTABLE POWER SUPPLY (UPS)
873001-02	TRAFFIC SIGNAL GROUNDING & BONDING
877001-05	STEEL MAST ARM ASSEMBLY AND POLE
878001-09	CONCRETE FOUNDATION DETAILS
880006-01	TRAFFIC SIGNAL MOUNTING DETAILS
886001-01	DETECTOR LOOP INSTALLATIONS
886006-01	TYPICAL LAYOUTS FOR DETECTION LOOPS

INDEX OF SHEETS

SHEET NO.	TITLE
1	COVER SHEET
2	INDEX OF SHEETS & STATE STANDARDS
3	GENERAL NOTES
4 - 6	SUMMARY OF QUANTITIES
7	EXISTING TYPICAL SECTIONS
8	PROPOSED TYPICAL SECTIONS
9	ALIGNMENT SHEET
10 - 11	EXISTING AND REMOVAL PLANS
12 - 13	PROPOSED PLANS
14	ROADWAY DETAILS
15 - 16	PROPOSED PAVEMENT MARKING & SIGNING PLANS
17 - 18	PROPOSED LANDSCAPING & EROSION CONTROL PLANS
19	TEMPORARY TRAFFIC SIGNAL INSTALLATION AND REMOVAL
20	TEMPORARY CABLE PLAN
21 - 23	TRAFFIC SIGNAL IMPROVEMENT PLANS
24	TS-02, DIST 1: MAST ARM MOUNTED STREET SIGNS: CRAWFORD AVENUE AT CHURCH STREET
25	BD-01, DIST 1: DRIVEWAY DETAILS DISTANCE BETWEEN R.O.W. AND FACE OF CURB/EDGE OF SHOULDER >= 15' (4.5m)
26	BD-02, DIST 1: DRIVEWAY DETAILS DISTANCE BETWEEN R.O.W. AND FACE OF CURB < 15' (4.5m)
27	BD-08, FRAMES AND LIDS ADJUSTMENT WITH MILLING; AND FRAMES AND LIDS ADJUSTMENT WITHOUT MILLING
28	BD-32, DIST 1: BUTT JOINT AND HMA TAPER DETAILS
29	BD-36, FIRE HYDRANT TO BE MOVED
30	TC-10, DIST 1: TRAFFIC CONTROL AND PROTECTION FOR SIDE ROADS, INTERSECTIONS, AND DRIVEWAYS
31	TC-11, DIST 1: RAISED REFLECTIVE PAVEMENT MARKERS (SNOW-PLOW RESISTANT)
32	TC-13, DIST 1: DISTRICT ONE TYPICAL PAVEMENT MARKINGS
33	TC-14, DIST 1: TRAFFIC CONTROL AND PROTECTION AT TURN BAYS (TO REMAIN OPEN TO TRAFFIC)
34	TC-16, DIST 1: PAVEMENT MARKING LETTERS AND SYMBOLS FOR TRAFFIC STAGING
35	TC-22, DIST 1: ARTERIAL ROAD INFORMATION SIGN
36	TC-26, DIST 1: DRIVEWAY ENTRANCE SIGNING
37 - 42	TS-05, DIST 1: STANDARD TRAFFIC SIGNAL DESIGN DETAILS
43 - 46	COOK COUNTY HIGHWAY DEPARTMENT STANDARD MARKING AND SIGNAGE DETAILS
47	COOK COUNTY HIGHWAY DEPARTMENT SURVEY MONUMENT DETAIL

TYLIN INTERNATIONAL USER NAME: #USER# PLOT SCALE: #SCALE# PLOT DATE: 10/28/2013	DESIGNED - MBR	REVISED -	STATE OF ILLINOIS DEPARTMENT OF TRANSPORTATION	INTERSECTION IMPROVEMENT CHURCH STREET AT CRAWFORD AVENUE INDEX OF SHEETS & STATE STANDARDS		F.A.U. RTE. 1313	SECTION 00-00241-00-CH	COUNTY COOK	TOTAL SHEETS 47	SHEET NO. 2	
	DRAWN -	REVISED -		SCALE:	SHEET NO.	OF SHEETS	STA.	TO STA.	FED. ROAD DIST. NO.	ILLINOIS FED. AID PROJECT	CONTRACT NO. 63734
	CHECKED - DBD	REVISED -		DATE - 10/18/2013	REVISED -						

GENERAL NOTES:

1. ALL CONSTRUCTION SHALL BE DONE IN ACCORDANCE WITH THE "STANDARD SPECIFICATIONS FOR ROAD AND BRIDGE CONSTRUCTION", ADOPTED JANUARY 1, 2012; THE "SUPPLEMENTAL SPECIFICATIONS AND RECURRING SPECIAL PROVISIONS", ADOPTED JANUARY 1, 2014; THE LATEST EDITION OF THE "ILLINOIS MANUAL ON UNIFORM TRAFFIC CONTROL DEVICES FOR STREETS AND HIGHWAYS" (MUTCD); THE "DETAILS" IN THE PLANS AND THE "SPECIAL PROVISIONS" INCLUDED IN THE CONTRACT DOCUMENTS.
2. THE CONTRACTOR SHALL MAINTAIN ALL ROADWAYS OPEN TO TRAFFIC AS SHOWN ON THE MAINTENANCE OF TRAFFIC PLANS STANDARD DETAILS.
3. BEFORE STARTING ANY EXCAVATION, THE CONTRACTOR SHALL CALL J.U.L.I.E. AT (800) 892-0123 FOR FIELD LOCATIONS OF BURIED ELECTRIC, TELEPHONE, CABLE, AND GAS FACILITIES (48 HOURS NOTIFICATION IS REQUIRED). CONTACT PUBLIC WORKS, VILLAGE OF SKOKIE AT (847) 933-8277 FOR SEWER AND WATER LOCATIONS.
4. FOR STABILIZATION, ALL TYPE III BARRICADES SHALL REQUIRE A MINIMUM OF FOUR SAND BAGS PER BARRICADE.
5. NIGHT OPERATIONS: WHEN ARTIFICIAL LIGHTING IS UTILIZED IN NIGHT OPERATIONS, THE CONTRACTOR SHALL EXERCISE THE UTMOST PRECAUTION IN PREVENTING ADVERSE VISIBILITY TO THE MOTORING PUBLIC AS WELL AS THE ADJOINING RESIDENTIAL AREAS.
6. WHEN MILLED PAVEMENT IS OPEN TO TRAFFIC, THE MAXIMUM GRADE DIFFERENTIAL BETWEEN PASSES OF THE MILLING MACHINE SHALL NOT EXCEED 1/2 INCHES WHERE THE SPEED LIMIT IS 45 MPH OR LESS AND 1 INCH WHERE THE SPEED LIMIT IS GREATER THAN 45 MPH. WITH WRITTEN APPROVAL FROM THE ENGINEER, A MAXIMUM GRADE DIFFERENTIAL OF 3 INCHES MAY BE ALLOWED IF THE EDGE OF THE MILLING IS SLOPED A MINIMUM 1:3 (V:H).
7. BUTT JOINTS WILL BE INSTALLED AT THE ENDS OF ALL RESURFACING (WHERE RESURFACING MEETS EXISTING PAVEMENT) IN ACCORDANCE WITH DISTRICT 1 DETAIL BD-32 "BUTT JOINT AND HMA TAPER DETAILS" INCLUDED IN THE PLANS, UNLESS OTHERWISE SPECIFIED.
8. THE ENGINEER SHALL BE THE SOLE JUDGE CONCERNING CURING TIME FOR VARIOUS HOT-MIX ASPHALT LIFTS.
9. ALL HORIZONTAL COORDINATES AND VERTICAL ELEVATIONS REFER TO NAD83 (CORS) ILLINOIS EAST ZONE HORIZONTAL DATUM AND NAVD88 VERTICAL DATUM, RESPECTIVELY.
10. A "BOXED" NOTE INDICATES AN ITEM OF WORK THAT IS NOT PAID FOR SEPARATELY, BUT IS PAID FOR AS PART OF ANOTHER ITEM LISTED IN THE SUMMARY OF QUANTITIES.
11. 10 FT TRANSITIONS SHALL BE USED TO MATCH PROPOSED ITEMS OF WORK TO EXISTING ITEMS IN THE FIELD, UNLESS OTHERWISE SHOWN. THE TRANSITIONS SHALL BE PAID FOR AT THE CONTRACT UNIT PRICE FOR THE PROPOSED ITEM OF WORK SPECIFIED.
12. THE SCALE SHOWN ON THE DRAWINGS APPLIES ONLY TO FULL SIZE PLANS AND NOT TO THE REDUCED SIZE PLANS.
13. DIMENSIONS: IT SHALL BE THE CONTRACTOR'S RESPONSIBILITY TO VERIFY ALL DIMENSIONS AND CONDITIONS EXISTING IN THE FIELD PRIOR TO ORDERING MATERIALS AND BEGINNING CONSTRUCTION.
14. THE LOCATIONS OF EXISTING DRAINAGE STRUCTURES, STORM AND SANITARY SEWERS, WATER SERVICE LINES AND OTHER UTILITY LINES ARE APPROXIMATE, AND IDOT/VILLAGE OF SKOKIE DOES NOT GUARANTEE THEIR ACCURACY. THEIR EXACT HORIZONTAL AND VERTICAL LOCATIONS ARE TO BE DETERMINED IN THE FIELD BY THE CONTRACTOR AT HIS OWN EXPENSE.
15. THE CONTRACTOR SHALL CONTACT J.U.L.I.E. PRIOR TO CONSTRUCTION AND COORDINATE ACTIVITIES WITH THE ENGINEER.
16. THE CONTRACTOR SHALL BE RESPONSIBLE FOR THE PROTECTION OF ALL UNDERGROUND OR SURFACE UTILITIES EVEN THOUGH THEY MAY NOT BE SHOWN ON THE PLANS. ANY UTILITY THAT IS DAMAGED DURING CONSTRUCTION SHALL BE REPAIRED OR REPLACED TO THE SATISFACTION OF THE ENGINEER. THIS WORK SHALL BE AT THE CONTRACTOR'S EXPENSE.
17. ANY EXISTING OR PROPOSED STORM SEWER DAMAGED BY THE CONTRACTOR DURING CONSTRUCTION SHALL BE REPLACED TO THE SATISFACTION OF THE ENGINEER AT THE CONTRACTOR'S EXPENSE.
18. FOR WATER MAIN SHUT OFFS, THE CONTRACTOR SHALL GIVE THE VILLAGE OF SKOKIE A MINIMUM OF 48 HOURS NOTICE. THE VILLAGE OF SKOKIE SHALL PROVIDE NOTIFICATION FORMS AND DETERMINE THE LIMIT OF THE AFFECTED AREAS. THE CONTRACTOR SHALL BE RESPONSIBLE FOR DISTRIBUTION OF THE NOTIFICATION FORMS TO ALL AFFECTED RESIDENTS.
19. THE CONTRACTOR SHALL NOT OPEN OR SHUT ANY WATER VALVES OR FIRE HYDRANTS WITHOUT PRIOR WRITTEN AUTHORIZATION FROM THE VILLAGE OF SKOKIE. UNAUTHORIZED USE IS SUBJECT TO ARREST AND PROSECUTION.
20. ANY ABANDONED UTILITY OR SEWER ENCOUNTERED DURING CONSTRUCTION OR ANY EXISTING UTILITY OR SEWER ABANDONED AS PART OF THE CONSTRUCTION THAT IS NOT BEING FILLED WITH C.L.S.M., AS PER PLAN, SHALL BE PLUGGED AS DIRECTED BY THE ENGINEER AND ABANDONED IN PLACE. THIS WORK SHALL BE INCLUDED IN THE COST OF MOBILIZATION.

21. DURING CONSTRUCTION OPERATIONS, IF ANY LOOSE MATERIAL IS DEPOSITED IN THE FLOW LINE OF DRAINAGE STRUCTURES SUCH THAT THE NATURAL FLOW OF WATER IS OBSTRUCTED, THE MATERIAL SHALL BE REMOVED AT THE CLOSE OF EACH WORKING DAY. AT THE CONCLUSION OF CONSTRUCTION OPERATIONS, ALL UTILITY STRUCTURES SHALL BE FREE FROM DUST AND DEBRIS. THE WORK SPECIFIED ABOVE WILL NOT BE PAID SEPARATELY BUT SHALL BE INCLUDED IN THE COST OF THE CONTRACT.
22. THE CONTRACTOR SHALL MAINTAIN THE SURFACE DRAINAGE OF ALL ROADWAYS DURING CONSTRUCTION OF THIS PROJECT. WHEN EXISTING DRAINAGE FACILITIES ARE DISTURBED, THE CONTRACTOR SHALL PROVIDE AND MAINTAIN TEMPORARY OUTLETS AND CONNECTIONS FOR ALL PRIVATE OR PUBLIC DRAINS, SEWERS, AND CATCH BASINS. HE SHALL PROVIDE FACILITIES TO TAKE IN ALL STORM WATER WHICH WILL BE RECEIVED BY THESE DRAINS AND SEWERS AND DISCHARGE THE SAME. HE SHALL PROVIDE AND MAINTAIN A PUMPING PLANT, IF NECESSARY, AND A TEMPORARY OUTLET AND BE PREPARED AT ALL TIMES TO DISPOSE OF THE WATER RECEIVED FROM THESE TEMPORARY CONNECTIONS UNTIL SUCH TIME AS THE PERMANENT CONNECTIONS WITH SEWERS ARE BUILT AND IN SERVICE. THIS WORK SHALL BE INCLUDED IN THE COST OF THE CONTRACT.
23. FENCE: EXISTING FENCE THAT HAS TO BE DISCONNECTED AND/OR REMOVED FOR THE CONTRACTOR'S OPERATION SHALL BE RECONNECTED AND/OR REPLACED BY THE CONTRACTOR IN KIND AT NO ADDITIONAL COST TO THE DEPARTMENT. TEMPORARY FENCE SHOULD BE INSTALLED IF EXISTING FENCE IS REMOVED BY THE CONTRACTOR IN ACCORDANCE WITH THE STANDARD SPECIFICATIONS. ANY RIGHT-OF-WAY MARKERS DISTURBED BY THE CONTRACTOR'S OPERATION SHALL BE REESTABLISHED BY A REGISTERED LAND SURVEYOR AT THE CONTRACTOR'S EXPENSE.
24. THE ENGINEER SHALL CONTACT THE IDOT TRAFFIC CONTROL SUPERVISOR AT 847-705-4470 AND THE CCHD AT 708-388-1893 A MINIMUM OF 72 HOURS PRIOR TO THE PLACEMENT OF ANY TEMPORARY TRAFFIC CONTROL DEVICES.
25. IT SHALL BE THE CONTRACTOR'S RESPONSIBILITY TO NOTIFY IDOT AND/OR CCHD AT LEAST 10 DAYS IN ADVANCE OF ANY CONSTRUCTION NEAR DEPARTMENT OWNED ELECTRICAL, COMMUNICATIONS, OR TRAFFIC CONTROL CABLES. IDOT AND/OR CCHD ELECTRICIANS WILL LOCATE ANY POSSIBLE INTERFERING CABLES. ANY BURIED CABLE AT OR NEAR A PROPOSED CONSTRUCTION LOCATION SHALL FIRST BE EXPOSED BY THE CONTRACTOR BY HAND DIGGING. ONCE EXPOSED, AND IF THE ENGINEER DETERMINES THERE IS A CONFLICT, THE CONTRACTOR SHALL RELOCATE THE CABLES. IF THE CONTRACTOR CUTS OR DAMAGES ANY CABLES, EITHER THROUGH CARELESSNESS OR FAILURE TO FOLLOW THE ABOVE PROCEDURE, HE SHALL THEN BE HELD RESPONSIBLE FOR THE REPAIRING OF ALL DAMAGES AT HIS EXPENSE, TO THE SATISFACTION OF THE AGENCY.
26. THE CONTRACTOR SHALL TAKE ALL NECESSARY PRECAUTIONS TO PROTECT AND PROVIDE ACCESS TO ABUTTING PROPERTY, UTILITIES, PEDESTRIANS, AND VEHICULAR TRAFFIC.
27. NO PAYMENT WILL BE MADE FOR RESTORATION BEYOND THE LIMITS SHOWN ON THE PLANS.
28. THE CONTRACTOR SHALL USE CARE IN GRADING OR EXCAVATING NEAR ANY AND ALL EXISTING ITEMS THAT WILL NOT BE REMOVED. ANY DAMAGE DONE TO EXISTING ITEMS BY THE CONTRACTOR SHALL BE REPAIRED OR REPLACED AT THE CONTRACTOR'S OWN EXPENSE.
29. ANY EXISTING UTILITY ADJUSTMENT AGREEMENTS AND SCHEDULES FOR THE ADJUSTMENT OF UTILITIES, WHICH MAY AFFECT THE WORK, WILL BE MADE AVAILABLE TO THE BIDDERS UPON REQUEST.
30. THE BITUMINOUS MATERIAL PRIME COAT QUANTITIES HAVE BEEN DETERMINED USING A RATE OF 0.10 GAL/SO YD.
31. THE CONTRACTOR SHALL BE RESPONSIBLE FOR PROTECTING AND PRESERVING THE PROJECT'S SURVEY CONTROL POINTS AND BENCHMARKS. RELOCATING AND REPLACING CONTROL POINTS AND BENCHMARKS SHALL BE THE CONTRACTOR'S RESPONSIBILITY AT HIS OWN EXPENSE.
32. ALL TRENCHES AND OPENINGS MADE IN THE ROADWAY SHALL BE BACKFILLED WITH SAND OR LIMESTONE SCREENING ADEQUATELY COMPACTED IN ACCORDANCE WITH METHOD 1 SPECIFIED IN ARTICLE 550.07 OF THE STATE STANDARD SPECIFICATIONS.
33. THE RESIDENT ENGINEER SHALL CONTACT WALTER CZARNY, AREA TRAFFIC FIELD ENGINEER AT (847) 715-8419 AT LEAST (2) WEEKS PRIOR TO PLACING PERMANENT PAVEMENT MARKINGS.
34. THE CONTRACTOR SHALL CONTACT THE DISTRICT ONE TRAFFIC CONTROL SUPERVISOR AT (847) 705-4470 A MINIMUM OF 72 HOURS IN ADVANCE OF BEGINNING WORK.
35. THE MAXIMUM ALLOWABLE DROP-OFF HEIGHT ALONG ANY ROUTE WITH A NORMAL POSTED SPEED LESS THAN 45 MPH SHALL BE 18 INCHES, UNLESS THE LENGTH OF CONSTRUCTION WHERE A DROP-OFF CONDITION OF LESS THAN 24 INCHES EXISTS IS LESS THAN 0.5 MILES OR 48 HOURS, OR THE DROP-OFF IS PROTECTED BY TEMPORARY TRAFFIC BARRIER. ON ROUTES WITH NORMAL POSTED SPEED OF 45 MPH OR GREATER, THE MAXIMUM ALLOWABLE DROP-OFF HEIGHT SHALL BE 12 INCHES, UNLESS THE LENGTH OF CONSTRUCTION WHERE A DROP-OFF CONDITION OF LESS THAN 18 INCHES EXISTS IS LESS THAN 0.5 MILES OR 48 HOURS, OR THE DROP-OFF IS PROTECTED BY TEMPORARY TRAFFIC BARRIER.
36. THE GENERAL CONTRACTOR IS REQUIRED TO HIRE AN ENVIRONMENTAL FIRM WITH AT LEAST FIVE (5) DOCUMENTED LEAKING UNDERGROUND STORAGE TANK CLEAN-UPS OR THAT IS PRE-QUALIFIED IN HAZARDOUS WASTE BY THE DEPARTMENT TO REMEDIATE THE SOIL CONTAMINATION AND MONITOR FOR WORKER PROTECTION. THIS FIRM WILL BE REQUIRED TO CONTINUOUSLY MONITOR FOR WORKER SAFETY AND SOIL CONTAMINATION AT SEVERAL LOCATIONS. SEE SPECIAL PROVISIONS AND SUPPLEMENTAL SPECIFICATIONS FOR DETAILS.

GENERAL NOTES - SEDIMENT AND EROSION CONTROL

1. EROSION CONTROL ITEMS ARE CONSIDERED TO BE HIGH PRIORITY ITEMS ON THIS CONTRACT. THE ENGINEER WILL IMPLEMENT ALL PROVISIONS OF THE SPECIFICATION NECESSARY TO ASSURE THAT EROSION CONTROL ITEMS ARE CONSTRUCTED AND MAINTAINED IN A TIMELY WAY. ALL EROSION CONTROL MEASURES SHALL BE INSTALLED PRIOR TO BEGINNING ANY CONSTRUCTION ACTIVITIES, WHICH WILL POTENTIALLY CREATE ERODIBLE CONDITIONS.
2. THE EROSION CONTROL MEASURES SHOWN ARE ONLY A GRAPHICAL REPRESENTATION OF SUGGESTED MEASURES. DEVIATIONS FROM THIS PLAN ARE TO BE EXPECTED PENDING A JOB SITE INSPECTION BETWEEN THE CONTRACTOR AND THE ENGINEER.
3. THE CONTRACTOR WILL BE REQUIRED TO IMPLEMENT AND MAINTAIN SEDIMENT CONTROL MEASURES PRIOR TO STRIPPING EXISTING VEGETATION.

DEFINITIONS

IDOT: ILLINOIS DEPARTMENT OF TRANSPORTATION
 AGENCY: IDOT
 CCHD: COOK COUNTY HIGHWAY DEPARTMENT
 VILLAGE: VILLAGE OF SKOKIE

TYLIN INTERNATIONAL

USER NAME: - #05814	DESIGNED - MBR	REVISED -
PLOT SCALE: - #SCALE4	DRAWN - MBR	REVISED -
PLOT DATE: - 10/17/2013	CHECKED - DBD	REVISED -
	DATE - 10/18/2013	REVISED -

**STATE OF ILLINOIS
 DEPARTMENT OF TRANSPORTATION**

**INTERSECTION IMPROVEMENT
 CHURCH STREET AT CRAWFORD AVENUE
 GENERAL NOTES**

SCALE: SHEET NO. OF SHEETS STA. TO STA.

F.A.U. RTE. 1313	SECTION 00-00241-00-CH	COUNTY COOK	TOTAL SHEETS 47	SHEET NO. 3
CONTRACT NO. 63734			FED. ROAD DIST. NO. [ILLINOIS] FED. AID PROJECT	

SUMMARY OF QUANTITIES

IDOT PAY ITEM NUMBER	DESCRIPTION	UNIT	TOTAL	ROADWAY 0004	TRAFFIC SIGNALS 0021	EVP VILLAGE OF SKOKIE 0021
20101100	TREE TRUNK PROTECTION	EACH	20	20		
20200100	EARTH EXCAVATION	CU YD	795	795		
20201200	REMOVAL AND DISPOSAL OF UNSUITABLE MATERIAL	CU YD	199	199		
21001000	GEOTECHNICAL FABRIC FOR GROUND STABILIZATION	SQ YD	1159	1159		
21101615	TOPSOIL FURNISH AND PLACE, 4"	SQ YD	1195	1195		
25000400	NITROGEN FERTILIZER NUTRIENT	POUND	23	23		
25000500	PHOSPHORUS FERTILIZER NUTRIENT	POUND	23	23		
25000600	POTASSIUM FERTILIZER NUTRIENT	POUND	23	23		
25200110	SODDING, SALT TOLERANT	SQ YD	1195	1195		
25200200	SUPPLEMENTAL WATERING	UNIT	54	54		
28000510	INLET FILTERS	EACH	15	15		
31101200	SUBBASE GRANULAR MATERIAL, TYPE B 4"	SQ YD	1318	1318		
31101400	SUBBASE GRANULAR MATERIAL, TYPE B 6"	SQ YD	2120	2120		
35300500	PORTLAND CEMENT CONCRETE BASE COURSE 10"	SQ YD	810	810		
40600100	BITUMINOUS MATERIALS (PRIME COAT)	GAL	1702	1702		
40600300	AGGREGATE (PRIME COAT)	TON	18	18		
40600400	MIXTURE FOR CRACKS, JOINTS, AND FLANGEWAYS	TON	2	2		
40600827	POLYMERIZED LEVELING BINDER (MACHINE METHOD), IL-4.75, N50	TON	428	428		
40600982	HOT-MIX ASPHALT SURFACE REMOVAL - BUTT JOINT	SQ YD	838	838		
40603340	HOT-MIX ASPHALT SURFACE COURSE, MIX "D", N70	TON	750	750		
42001300	PROTECTIVE COAT	SQ YD	1241	1241		
42300200	PORTLAND CEMENT CONCRETE DRIVEWAY PAVEMENT, 6 INCH	SQ YD	170	170		
42300400	PORTLAND CEMENT CONCRETE DRIVEWAY PAVEMENT, 8 INCH	SQ YD	325	325		
42400200	PORTLAND CEMENT CONCRETE SIDEWALK 5 INCH	SQ FT	7454	7454		
44000158	HOT-MIX ASPHALT SURFACE REMOVAL, 2 1/4"	SQ YD	3000	3000		
44000200	DRIVEWAY PAVEMENT REMOVAL	SQ YD	364	364		
44000500	COMBINATION CURB AND GUTTER REMOVAL	FOOT	4546	4546		
44000600	SIDEWALK REMOVAL	SQ FT	6615	6615		
44201349	CLASS C PATCHES, TYPE I, 10 INCH	SQ YD	50	50		
44201353	CLASS C PATCHES, TYPE II, 10 INCH	SQ YD	100	100		
44201357	CLASS C PATCHES, TYPE III, 10 INCH	SQ YD	100	100		
* 56400100	FIRE HYDRANTS TO BE MOVED	EACH	1	1		
* 56400300	FIRE HYDRANTS TO BE ADJUSTED	EACH	1	1		
60251500	CATCH BASINS TO BE ADJUSTED WITH NEW TYPE 11 FRAME AND GRATE	EACH	12	12		
60251730	CATCH BASINS TO BE ADJUSTED WITH NEW TYPE 23 FRAME AND GRATE	EACH	2	2		
60600605	CONCRETE CURB, TYPE B	FOOT	309	309		
60603800	COMBINATION CONCRETE CURB AND GUTTER, TYPE B-6.12	FOOT	3279	3279		
60618300	CONCRETE MEDIAN SURFACE, 4 INCH	SQ FT	156	156		
* 66900200	NON-SPECIAL WASTE DISPOSAL	CU YD	300	300		
* 66900450	SPECIAL WASTE PLANS AND REPORTS	L SUM	1	1		
* 66900530	SOIL DISPOSAL ANALYSIS	EACH	2	2		
67100100	MOBILIZATION	L SUM	1	1		
70102620	TRAFFIC CONTROL AND PROTECTION, STANDARD 701501	L SUM	1	1		
70102630	TRAFFIC CONTROL AND PROTECTION, STANDARD 701601	L SUM	1	1		

- * SPECIALTY ITEMS
- o SPECIAL PROVISION

TYLIN INTERNATIONAL <small>131602558.dwg</small>	<small>DESIGNED - MBR</small> <small>DRAWN -</small> <small>CHECKED - DBD</small> <small>DATE - 10/18/2013</small>	<small>REVISED -</small> <small>REVISED -</small> <small>REVISED -</small> <small>REVISED -</small>	STATE OF ILLINOIS DEPARTMENT OF TRANSPORTATION	INTERSECTION IMPROVEMENT CHURCH STREET AT CRAWFORD AVENUE SUMMARY OF QUANTITIES - SHEET 1 OF 3	<small>F.A.U. RTE.</small> 1313	<small>SECTION</small> 00-00241-00-CH	<small>COUNTY</small> COOK	<small>TOTAL SHEETS</small> 47	<small>SHEET NO.</small> 4	<small>CONTRACT NO.</small> 63734
	<small>SCALE:</small>		<small>SHEET NO. OF SHEETS</small>	<small>STA. TO STA.</small>	<small>FED. ROAD DIST. NO.</small>	<small>ILLINOIS FED. AID PROJECT</small>				

P:\602558\Froad\seq\S101.dwg 5:53:38 PM 10/17/2013

SUMMARY OF QUANTITIES

IDOT PAY ITEM NUMBER	DESCRIPTION	UNIT	TOTAL	ROADWAY 0004	TRAFFIC SIGNALS 0021	EVP VILLAGE OF SKOKIE 0021
70102635	TRAFFIC CONTROL AND PROTECTION, STANDARD 701701	L SUM	1	1		
70102640	TRAFFIC CONTROL AND PROTECTION, STANDARD 701801	L SUM	1	1		
70103815	TRAFFIC CONTROL SURVEILLANCE	CAL DA	85	85		
70106800	CHANGEABLE MESSAGE SIGN	CAL MO	24	24		
70300100	SHORT TERM PAVEMENT MARKING	FOOT	15765	15765		
70300210	TEMPORARY PAVEMENT MARKING LETTERS AND SYMBOLS	SO FT	440	440		
70300220	TEMPORARY PAVEMENT MARKING - LINE 4"	FOOT	5430	5430		
70300240	TEMPORARY PAVEMENT MARKING - LINE 6"	FOOT	2112	2112		
70300260	TEMPORARY PAVEMENT MARKING - LINE 12"	FOOT	1234	1234		
70300280	TEMPORARY PAVEMENT MARKING - LINE 24"	FOOT	420	420		
70301000	WORK ZONE PAVEMENT MARKING REMOVAL	SO FT	13449	13449		
72000100	SIGN PANEL - TYPE 1	SO FT	90	90		
72400310	REMOVE SIGN PANEL - TYPE 1	SO FT	70	70		
72400710	RELOCATE SIGN PANEL - TYPE 1	SO FT	5	5		
72800100	TELESCOPING STEEL SIGN SUPPORT	FOOT	39	39		
73100100	BASE FOR TELESCOPING STEEL SIGN SUPPORT	EACH	1	1		
78000100	THERMOPLASTIC PAVEMENT MARKING - LETTERS AND SYMBOLS	SO FT	219	219		
78000200	THERMOPLASTIC PAVEMENT MARKING - LINE 4"	FOOT	2715	2715		
78000400	THERMOPLASTIC PAVEMENT MARKING - LINE 6"	FOOT	1056	1056		
78000600	THERMOPLASTIC PAVEMENT MARKING - LINE 12"	FOOT	933	933		
78000650	THERMOPLASTIC PAVEMENT MARKING - LINE 24"	FOOT	210	210		
78100100	RAISED REFLECTIVE PAVEMENT MARKER	EACH	80	80		
80500020	SERVICE INSTALLATION - POLE MOUNTED	EACH	1		1	
81028200	UNDERGROUND CONDUIT, GALVANIZED STEEL, 2" DIA.	FOOT	675		675	
81028210	UNDERGROUND CONDUIT, GALVANIZED STEEL, 2 1/2" DIA.	FOOT	111		111	
81028220	UNDERGROUND CONDUIT, GALVANIZED STEEL, 3" DIA.	FOOT	73		73	
81028240	UNDERGROUND CONDUIT, GALVANIZED STEEL, 4" DIA.	FOOT	311		311	
81400100	HANDHOLE	EACH	7		7	
81400200	HEAVY-DUTY HANDHOLE	EACH	4		4	
81400300	DOUBLE HANDHOLE	EACH	2		2	
85700200	FULL-ACTUATED CONTROLLER AND TYPE IV CABINET	EACH	1		1	
87301215	ELECTRIC CABLE IN CONDUIT, SIGNAL NO. 14 2C	FOOT	1228		1228	
87301225	ELECTRIC CABLE IN CONDUIT, SIGNAL NO. 14 3C	FOOT	1569		1284	285
87301245	ELECTRIC CABLE IN CONDUIT, SIGNAL NO. 14 5C	FOOT	1101		1101	
87301255	ELECTRIC CABLE IN CONDUIT, SIGNAL NO. 14 7C	FOOT	1440		1440	
87301305	ELECTRIC CABLE IN CONDUIT, LEAD-IN, NO. 14 1 PAIR	FOOT	3308		3308	
87301805	ELECTRIC CABLE IN CONDUIT, SERVICE, NO. 6 2 C	FOOT	66		66	
87301900	ELECTRIC CABLE IN CONDUIT, EQUIPMENT GROUNDING CONDUCTOR, NO. 6 1C	FOOT	1191		1191	
87502500	TRAFFIC SIGNAL POST, GALVANIZED STEEL 16 FT.	EACH	4		4	
87700180	STEEL MAST ARM ASSEMBLY AND POLE, 28 FT.	EACH	2		2	
87700230	STEEL MAST ARM ASSEMBLY AND POLE, 38 FT.	EACH	1		1	
87700250	STEEL MAST ARM ASSEMBLY AND POLE, 42 FT.	EACH	1		1	
87800100	CONCRETE FOUNDATION, TYPE A	FOOT	16		16	
87800150	CONCRETE FOUNDATION, TYPE C	FOOT	4		4	

- SPECIALTY ITEMS
- SPECIAL PROVISION

TYLIN INTERNATIONAL	USER NAME - REVISED	DESIGNED - MBR	REVISED -	STATE OF ILLINOIS DEPARTMENT OF TRANSPORTATION	INTERSECTION IMPROVEMENT CHURCH STREET AT CRAWFORD AVENUE SUMMARY OF QUANTITIES - SHEET 2 OF 3		F.A.U. RTE. 1313	SECTION 00-00241-00-CH	COUNTY COOK	TOTAL SHEETS 47	SHEET NO. 5	
	PLT SCALE - AS SHOWN	CHECKED - DBD	REVISED -		SCALE:	SHEET NO.	OF SHEETS	STA.	TO STA.	CONTRACT NO. 63734		
	PLT DATE - 10/17/2013	DATE - 10/18/2013	REVISED -					FED. ROAD DIST. NO. [ILLINOIS] FED. AID PROJECT				

F:\602558\Road\sig\SH02.dgn 5:53:40 PM 10/17/2013

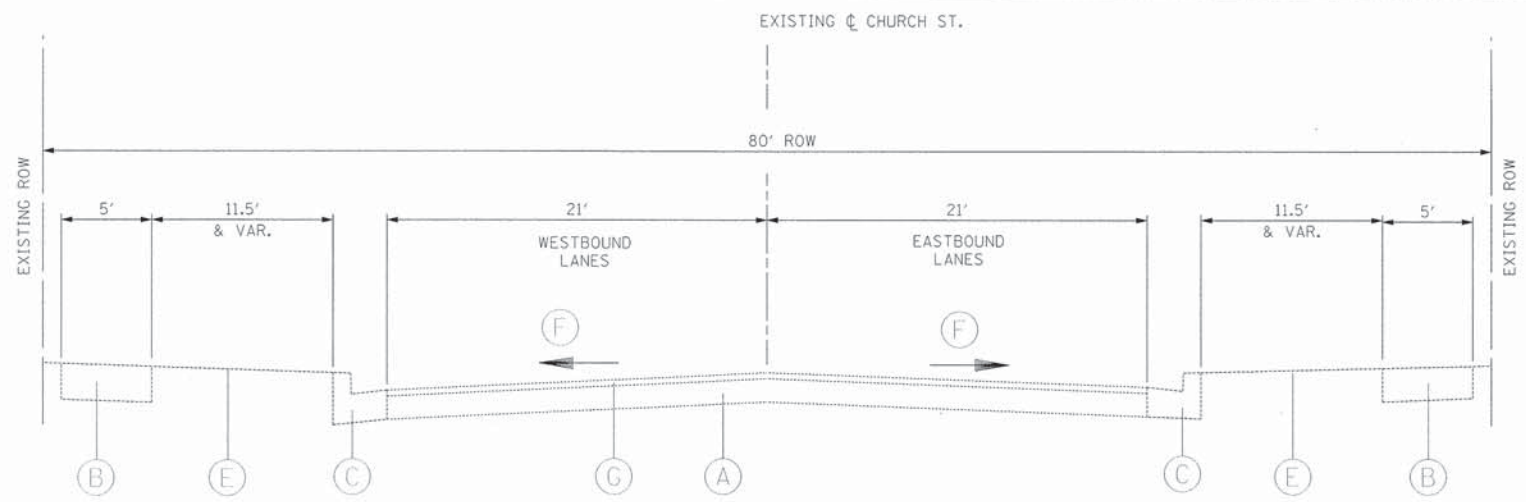

**EXISTING TYPICAL SECTION
CHURCH STREET**
 STA. 205+12.4 TO STA. 207+41.4 - CROSS SLOPE = ± 1.5%
 STA. 208+61.5 TO STA. 210+93.5 - CROSS SLOPE = ± 2.5%

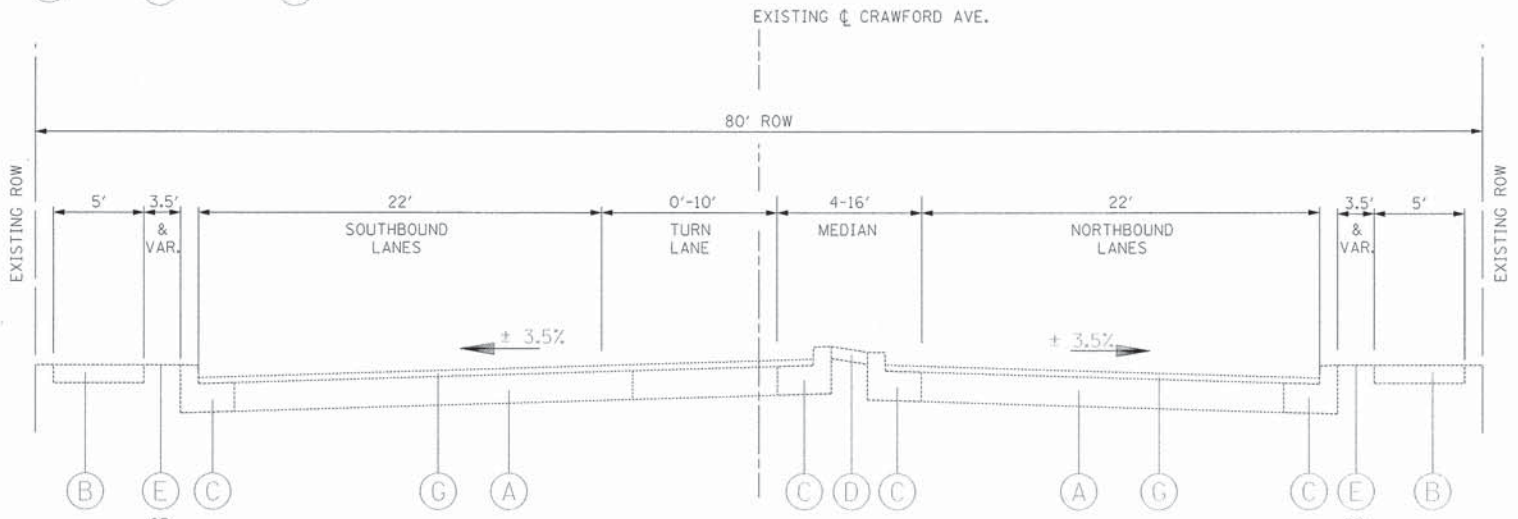

**EXISTING TYPICAL SECTION
CRAWFORD AVENUE**
 STA. 107+40.5 TO STA. 111+63.4

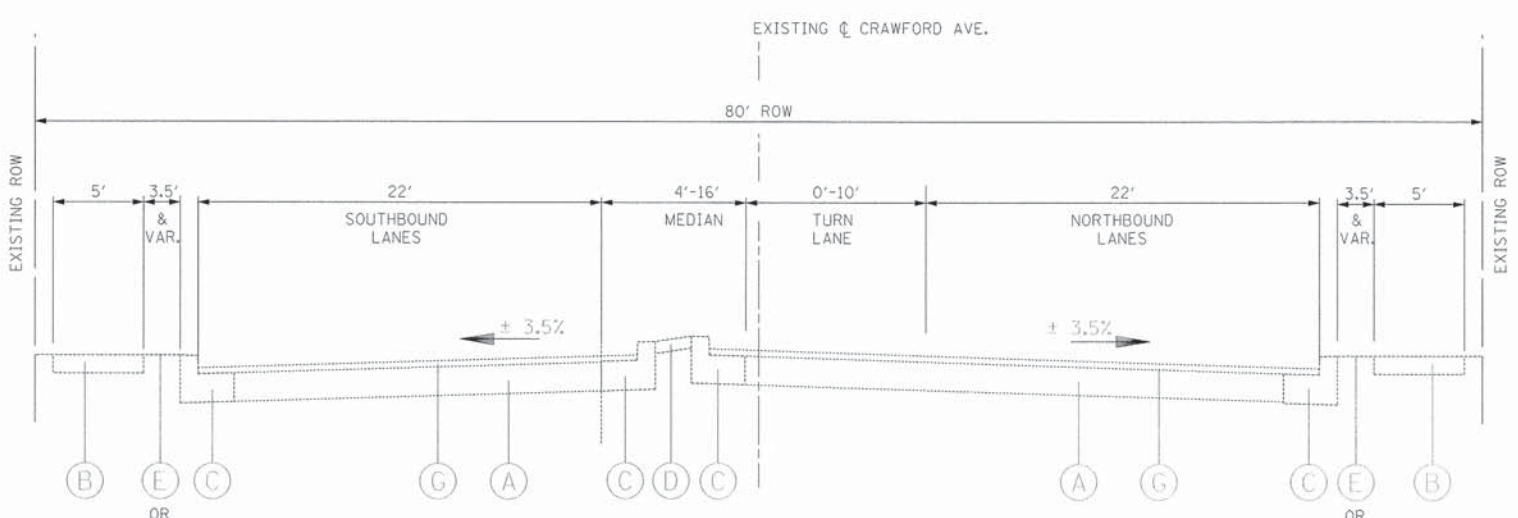

**EXISTING TYPICAL SECTION
CRAWFORD AVENUE**
 STA. 102+32.0 TO STA. 106+60.3

LEGEND:

- (A) EXISTING PCC BASE COURSE ±9"
- (B) EXISTING PCC SIDEWALK ±5"
- (C) EXISTING CURB AND GUTTER, TYPE B-6.12
- (D) EXISTING PCC MEDIAN SURFACE ±4"
- (E) EXISTING PARKWAY - LANDSCAPED
- (F) ± 1.5% WEST OF CRAWFORD AVENUE
± 2.5% EAST OF CRAWFORD AVENUE
- (G) EXISTING HMA SURFACE COURSE ± 3.0"

NOTE:
SEE REMOVAL PLANS AND ROADWAY DETAILS
FOR DETAILED REMOVAL INFORMATION.

TYLIN INTERNATIONAL USER NAME = #USER# PLOT SCALE = #SCALE# PLOT DATE = 10/17/2013	DESIGNED - MBR	REVISED -	STATE OF ILLINOIS DEPARTMENT OF TRANSPORTATION	INTERSECTION IMPROVEMENT CHURCH STREET AT CRAWFORD AVENUE EXISTING TYPICAL SECTIONS		F.A.U. RTE. 1313	SECTION 00-00241-00-CH	COUNTY COOK	TOTAL SHEETS 47	SHEET NO. 7
	DRAWN - CBS	REVISED -		SCALE:	SHEET NO. OF SHEETS	STA. TO STA.	CONTRACT NO. 63734		ILLINOIS FED. AID PROJECT	
	CHECKED - DBD	REVISED -								
DATE - 10/18/2013	REVISED -									

P:\602558\Road\typsec5Hpr.dgn 10/17/2013 5:53:47 PM

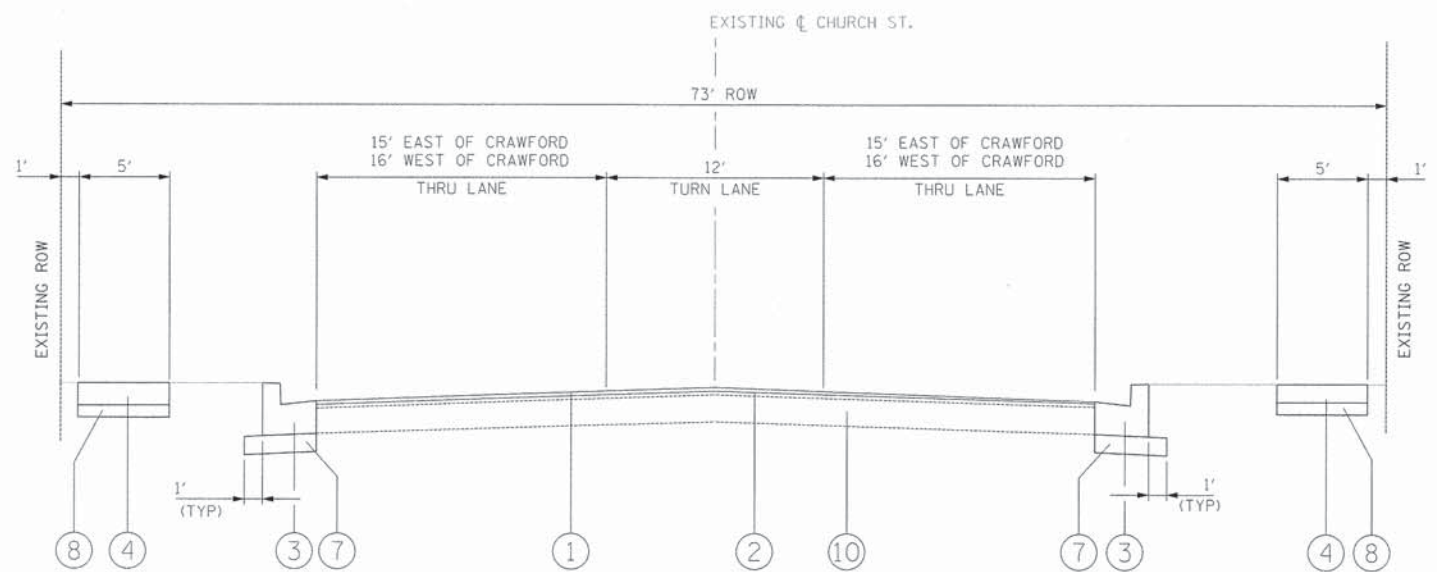

**PROPOSED TYPICAL SECTION
CHURCH STREET**

STA. 204+86.7 TO STA. 211+13.5 - 2 1/4" HMA SURFACE COURSE REMOVAL
(REPLACE WITH 1 1/2" HMA SURFACE COURSE AND 3/4" POLY LEVELING BINDER)
STA. 205+12.4 TO STA. 207+41.4 - CROSS SLOPE = ± 1.5%
STA. 208+61.5 TO STA. 210+93.5 - CROSS SLOPE = ± 2.5%

- LEGEND:**
- ① HOT-MIX ASPHALT SURFACE COURSE, MIX "D", N70 - 1 1/2"
 - ② POLYMERIZED LEVELING BINDER (MACHINE METHOD), IL-4.75, N50 - 3/4"
 - ③ COMBINATION CONCRETE CURB AND GUTTER, TYPE B-6.12
 - ④ PORTLAND CEMENT CONCRETE SIDEWALK, 5" (SEE PLANS FOR LOCATIONS)
 - ⑤ PORTLAND CEMENT CONCRETE BASE COURSE, 10"
 - ⑥ EXISTING PARKWAY
 - ⑦ SUB-BASE GRANULAR MATERIAL, TYPE B 6"
 - ⑧ SUB-BASE GRANULAR MATERIAL, TYPE B 4"
 - ⑨ POLYMERIZED LEVELING BINDER (MACHINE METHOD), IL-4.75, N50 - 1"
 - ⑩ EXISTING PCC BASE COURSE ±9"
 - ⑪ LANDSCAPED MEDIAN
 - ⑫ GEOTECHNICAL FABRIC FOR GROUND STABILIZATION
- NOTE: ALTERNATE SIDE TREATMENT ALONG CHURCH STREET AND CRAWFORD AVENUE INCLUDES DRIVEWAY RECONSTRUCTION. (SEE PLANS FOR LOCATIONS AND TYPE)

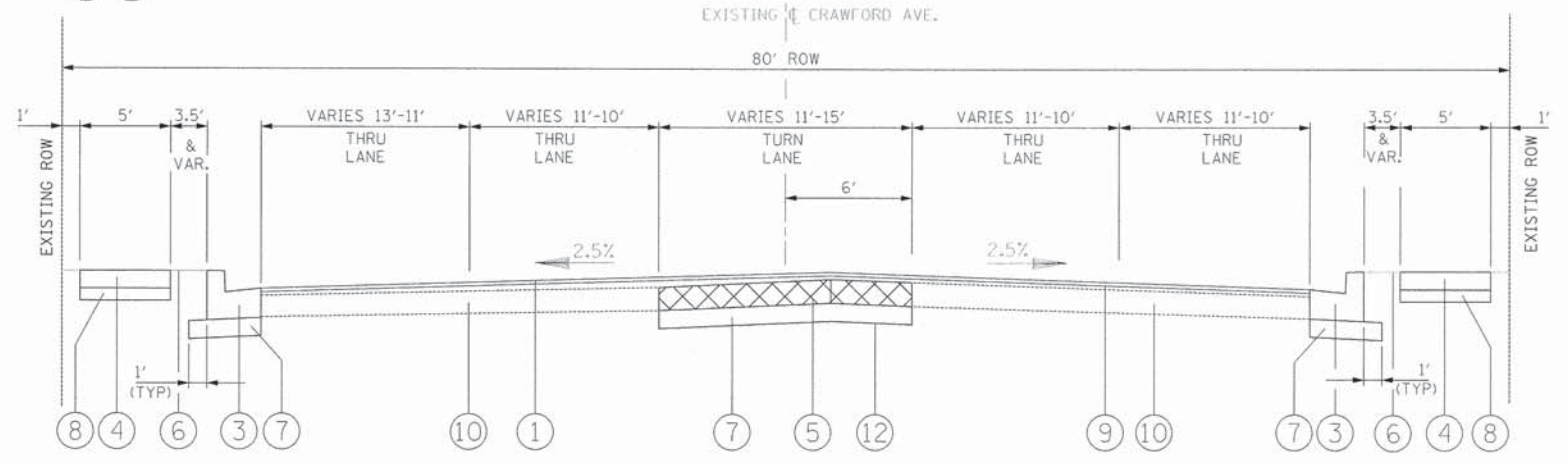

**PROPOSED TYPICAL SECTION
CRAWFORD AVENUE**

STA. 107+47.4 TO STA. 110+47.4 AND STA. 103+64.1 TO STA. 106+53.2
(SEE ROAD DETAILS SHEET FOR ADDITIONAL INFORMATION)

IDOT HOT-MIX ASPHALT MIXTURE REQUIREMENTS

MIXTURE TYPE	AIR VOIDS @ Ndes
ROADWAY RESURFACING	
HOT-MIX ASPHALT SURFACE COURSE, MIX "D", IL-9.5, N70 (1 1/2")	4% @ 70 Gyr.
POLYMERIZED LEVELING BINDER (MACHINE METHOD), IL-4.75, N50 (3/4")	3.5% @ 50 Gyr.
POLYMERIZED LEVELING BINDER (MACHINE METHOD), IL-4.75, N50 (1")	3.5% @ 50 Gyr.

THE UNIT WEIGHT USED TO CALCULATE ALL HMA SURFACE MIXTURE QUANTITIES IS 112 LBS/SQ YD/IN.

THE "AC TYPE" FOR POLYMERIZED HMA MIXES SHALL BE "SBS/SBR PG 76-22" AND FOR NON-POLYMERIZED HMA THE "AC TYPE" SHALL BE "PG 64-22" UNLESS MODIFIED BY DISTRICT ONE SPECIAL PROVISIONS.

FOR "PERCENT OF RAP" SEE DISTRICT ONE SPECIAL PROVISIONS.

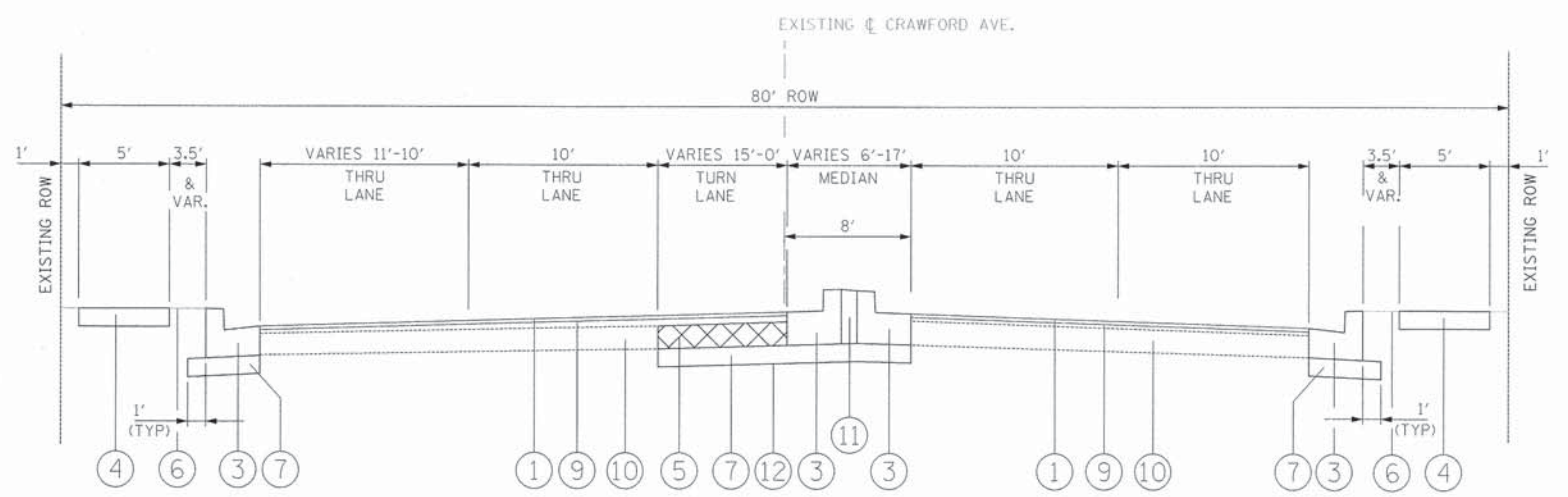

**PROPOSED TYPICAL SECTION
CRAWFORD AVENUE**

STA. 110+48.4 TO STA. 111+63.4 AND STA. 102+32.2 TO STA. 103+64.1
(SEE ROAD DETAILS SHEET FOR ADDITIONAL INFORMATION)

TYLIN INTERNATIONAL	USER NAME - RUSER19	DESIGNED - MBR	REVISED -	STATE OF ILLINOIS DEPARTMENT OF TRANSPORTATION	INTERSECTION IMPROVEMENT CHURCH STREET AT CRAWFORD AVENUE PROPOSED TYPICAL SECTIONS	F.A.U. RTE. 1313	SECTION 00-00241-00-CH	COUNTY COOK	TOTAL SHEETS 47	SHEET NO. 8	
	PLOT SCALE - 4SCALE19	DRAWN - CBS	REVISED -			SCALE: SHEET NO. OF SHEETS STA. TO STA.					
	PLOT DATE - 10/17/2013	CHECKED - DBD	REVISED -			FED. ROAD DIST. NO. [ILLINOIS] FED. AID PROJECT					
	DATE - 10/18/2013	DATE - 10/18/2013	REVISED -			CONTRACT NO. 63734					



CENTERLINE CHURCH STREET

STA. 200+00.00 N 1,960,659.75 E 1,147,969.44
 Course from 200+00.00 to 208+00.00 N 89° 30' 30.35" E Dist 800.00'
 STA. 208+00.00 N 1,960,666.61 E 1,148,769.42
 Course from 208+00.00 to 216+00.00 N 88° 46' 11.75" E Dist 800.00'
 STA. 216+00.00 N 1,960,683.78 E 1,149,569.23

CENTERLINE CRAWFORD AVENUE

STA. 100+00.00 N 1,959,966.64 E 1,148,762.34
 Course from 100+00.00 to 107+00.00 N 0° 34' 45.45" E Dist 700.00'
 STA. 107+00.00 N 1,960,666.61 E 1,148,769.42
 Course from 107+00.00 to 114+00.00 N 0° 29' 02.25" E Dist 700.00'
 STA. 114+00.00 N 1,961,366.58 E 1,148,775.33

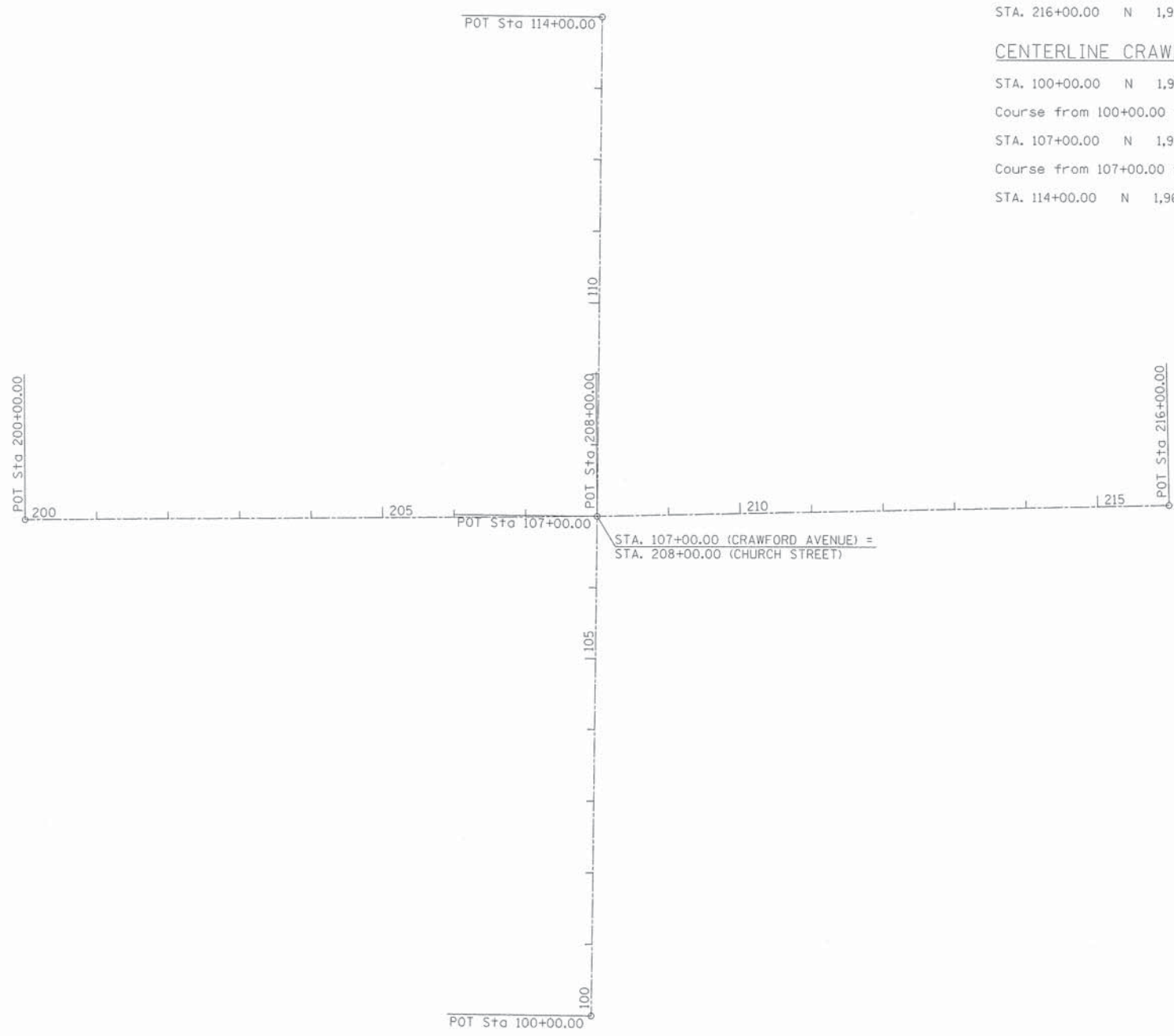

LOCATION MAP

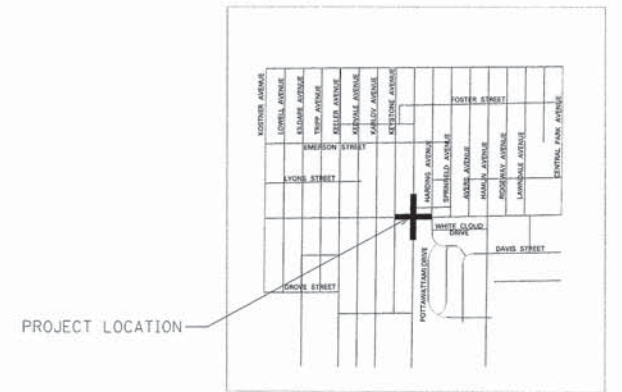

TYLIN INTERNATIONAL USER NAME - RUSER11 PLOT SCALE - 4SCALE1 PLOT DATE - 10/17/2013	DESIGNED - MBR	REVISED -	STATE OF ILLINOIS DEPARTMENT OF TRANSPORTATION	INTERSECTION IMPROVEMENT CHURCH STREET AT CRAWFORD AVENUE ALIGNMENT SHEET			F.A.U. RTE. 1313	SECTION 00-00241-00-CH	COUNTY COOK	TOTAL SHEETS 47	SHEET NO. 9
	DRAWN - CBS	REVISED -		SCALE:	SHEET NO.	OF SHEETS	STA.	TO STA.	CONTRACT NO. 63734		
	CHECKED - DBD	REVISED -		FED. ROAD DIST. NO. [ILLINOIS] FED. AID PROJECT							
DATE - 10/18/2013	REVISED -										

NOTE:

THE GENERAL CONTRACTOR IS REQUIRED TO HIRE AN ENVIRONMENTAL FIRM WITH AT LEAST FIVE (5) DOCUMENTED LEAKING UNDERGROUND STORAGE TANK CLEAN-UPS OR THAT IS PRE-QUALIFIED IN HAZARDOUS WASTE BY THE DEPARTMENT TO REMEDIATE THE SOIL CONTAMINATION AND MONITOR FOR WORKER PROTECTION. THIS FIRM WILL BE REQUIRED TO CONTINUOUSLY MONITOR FOR WORKER SAFETY AND SOIL CONTAMINATION AT SEVERAL LOCATIONS. SEE SPECIAL PROVISIONS AND SUPPLEMENTAL SPECIFICATIONS FOR DETAILS.

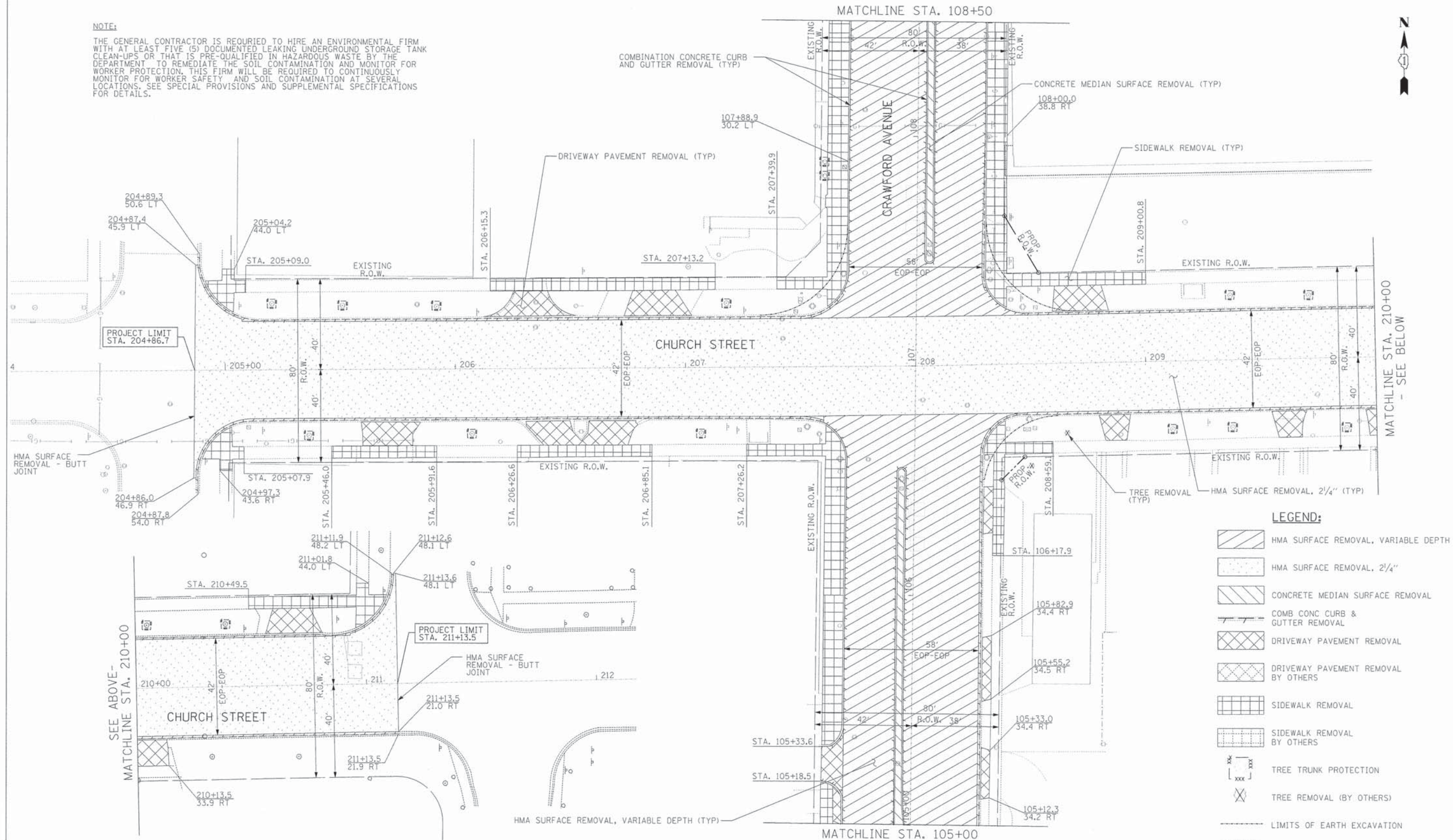

LEGEND:

- HMA SURFACE REMOVAL, VARIABLE DEPTH
- HMA SURFACE REMOVAL, 2 1/4"
- CONCRETE MEDIAN SURFACE REMOVAL
- COMB CONC CURB & GUTTER REMOVAL
- DRIVEWAY PAVEMENT REMOVAL
- DRIVEWAY PAVEMENT REMOVAL BY OTHERS
- SIDEWALK REMOVAL
- SIDEWALK REMOVAL BY OTHERS
- TREE TRUNK PROTECTION
- TREE REMOVAL (BY OTHERS)
- LIMITS OF EARTH EXCAVATION

NOTES:

- ALL STATION/OFFSET/RADIUS CALLOUTS MEASURED TO EDGE OF PAVEMENT UNLESS OTHERWISE NOTED.



TYLIN INTERNATIONAL

USER NAME = USERA	DESIGNED = MBR	REVISED =
PLOT SCALE = #SCALE#	DRAWN = DM	REVISED =
PLOT DATE = 10/17/2013	CHECKED = DBD	REVISED =
	DATE = 10/18/2013	REVISED =

**STATE OF ILLINOIS
DEPARTMENT OF TRANSPORTATION**

**INTERSECTION IMPROVEMENT
CHURCH STREET AT CRAWFORD AVENUE
EXISTING AND REMOVAL PLANS - SHEET 1 OF 2**

SCALE:	SHEET NO.	OF SHEETS	STA.	TO STA.
--------	-----------	-----------	------	---------

F.A.U. RTE.	SECTION	COUNTY	TOTAL SHEETS	SHEET NO.
1313	00-00241-00-CH	COOK	47	10
CONTRACT NO. 63734				
FED. ROAD DIST. NO.	ILLINOIS FED. AID PROJECT			

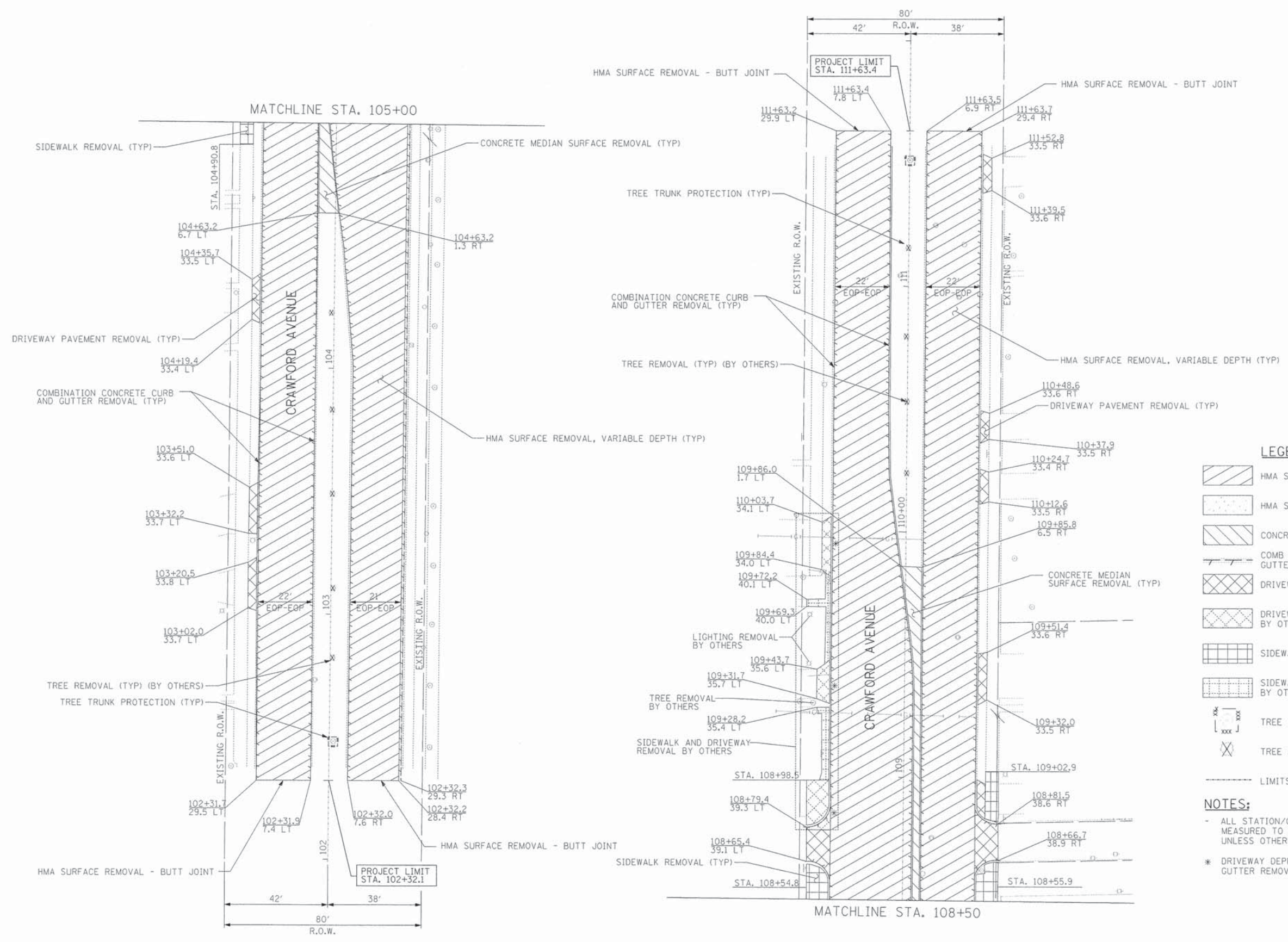

- LEGEND:**
- HMA SURFACE REMOVAL, VARIABLE DEPTH
 - HMA SURFACE REMOVAL, 2 1/4"
 - CONCRETE MEDIAN SURFACE REMOVAL
 - COMB CONC CURB & GUTTER REMOVAL
 - DRIVEWAY PAVEMENT REMOVAL
 - DRIVEWAY PAVEMENT REMOVAL BY OTHERS
 - SIDEWALK REMOVAL
 - SIDEWALK REMOVAL BY OTHERS
 - TREE TRUNK PROTECTION
 - TREE REMOVAL (BY OTHERS)
 - LIMITS OF EARTH EXCAVATION

- NOTES:**
- ALL STATION/OFFSET/RADIUS CALLOUTS MEASURED TO EDGE OF PAVEMENT UNLESS OTHERWISE NOTED.
 - * DRIVEWAY DEPRESSED CURB AND GUTTER REMOVAL BY OTHERS



TYLIN INTERNATIONAL	USER NAME = USER1	DESIGNED = MBR	REVISED =
	PLOT SCALE = 4SCALE4	DRAWN = DM	REVISED =
	PLOT DATE = 10/17/2013	CHECKED = DBD	REVISED =
		DATE = 10/18/2013	REVISED =

**STATE OF ILLINOIS
DEPARTMENT OF TRANSPORTATION**

**INTERSECTION IMPROVEMENT
CHURCH STREET AT CRAWFORD AVENUE
EXISTING AND REMOVAL PLANS - SHEET 2 OF 2**

F.A.U. RTE. 1313	SECTION 00-00241-00-CH	COUNTY COOK	TOTAL SHEETS 47	SHEET NO. 11
CONTRACT NO. 63734				
FED. ROAD DIST. NO. [ILLINOIS] FED. AID PROJECT				

F:\602558\Road\propaveSH01.dgn 5:53:58 PM 10/17/2013

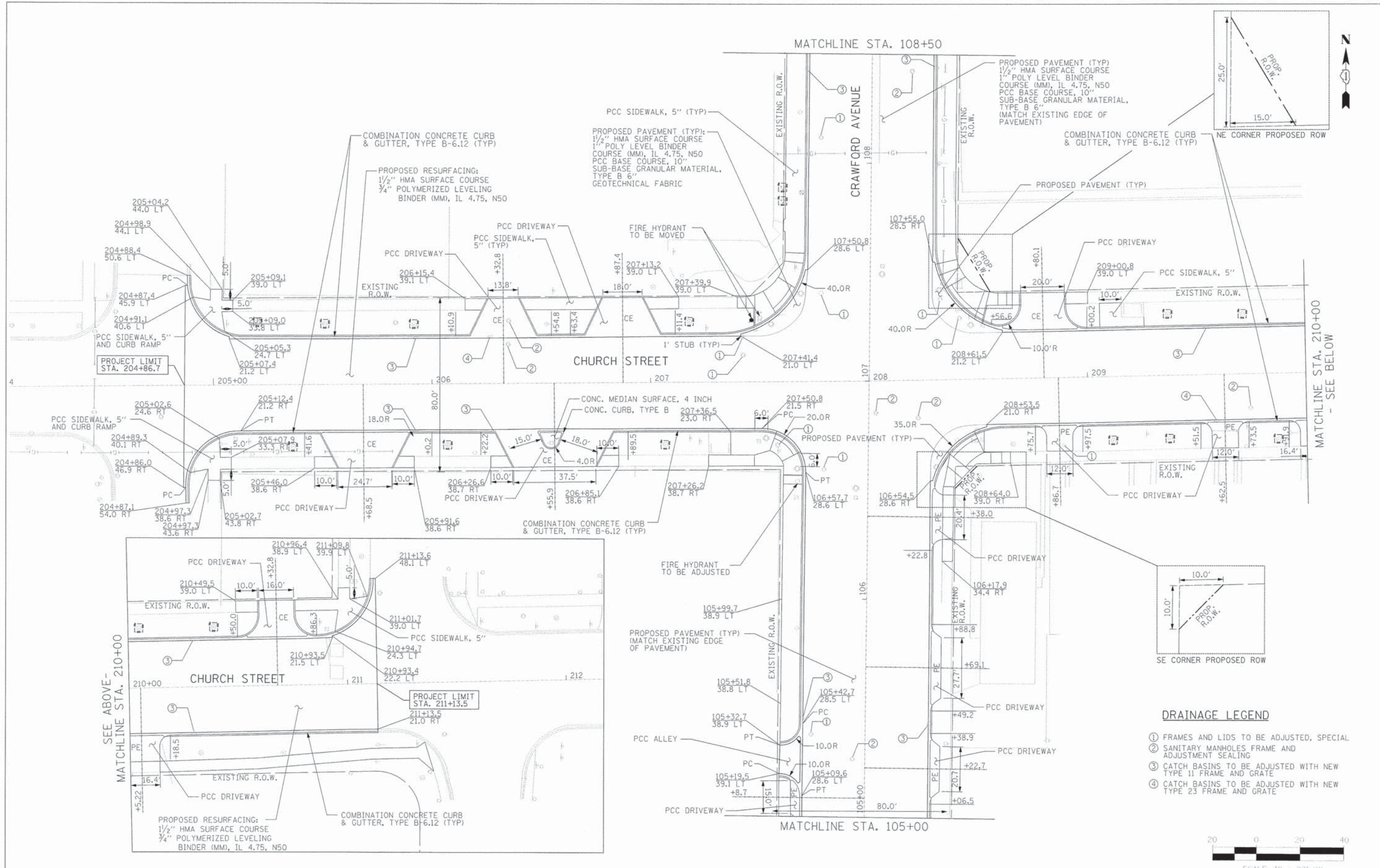

TYLIN INTERNATIONAL	USER NAME - USERS	DESIGNED - MBR	REVISED -
	PLOT SCALE - 1/4"=1'-0"	DRAWN - DM	REVISED -
	PLOT DATE - 10/17/2013	CHECKED - DBD	REVISED -
		DATE - 10/18/2013	REVISED -

**STATE OF ILLINOIS
DEPARTMENT OF TRANSPORTATION**

**INTERSECTION IMPROVEMENT
CHURCH STREET AT CRAWFORD AVENUE
PROPOSED PLAN - SHEET 1 OF 2**

SCALE: SHEET NO. OF SHEETS STA. TO STA.

F.A.U. RTE. 1313	SECTION 00-00241-00-CH	COUNTY COOK	TOTAL SHEETS 47	SHEET NO. 12
CONTRACT NO. 63734		ILLINOIS FED. AID PROJECT		

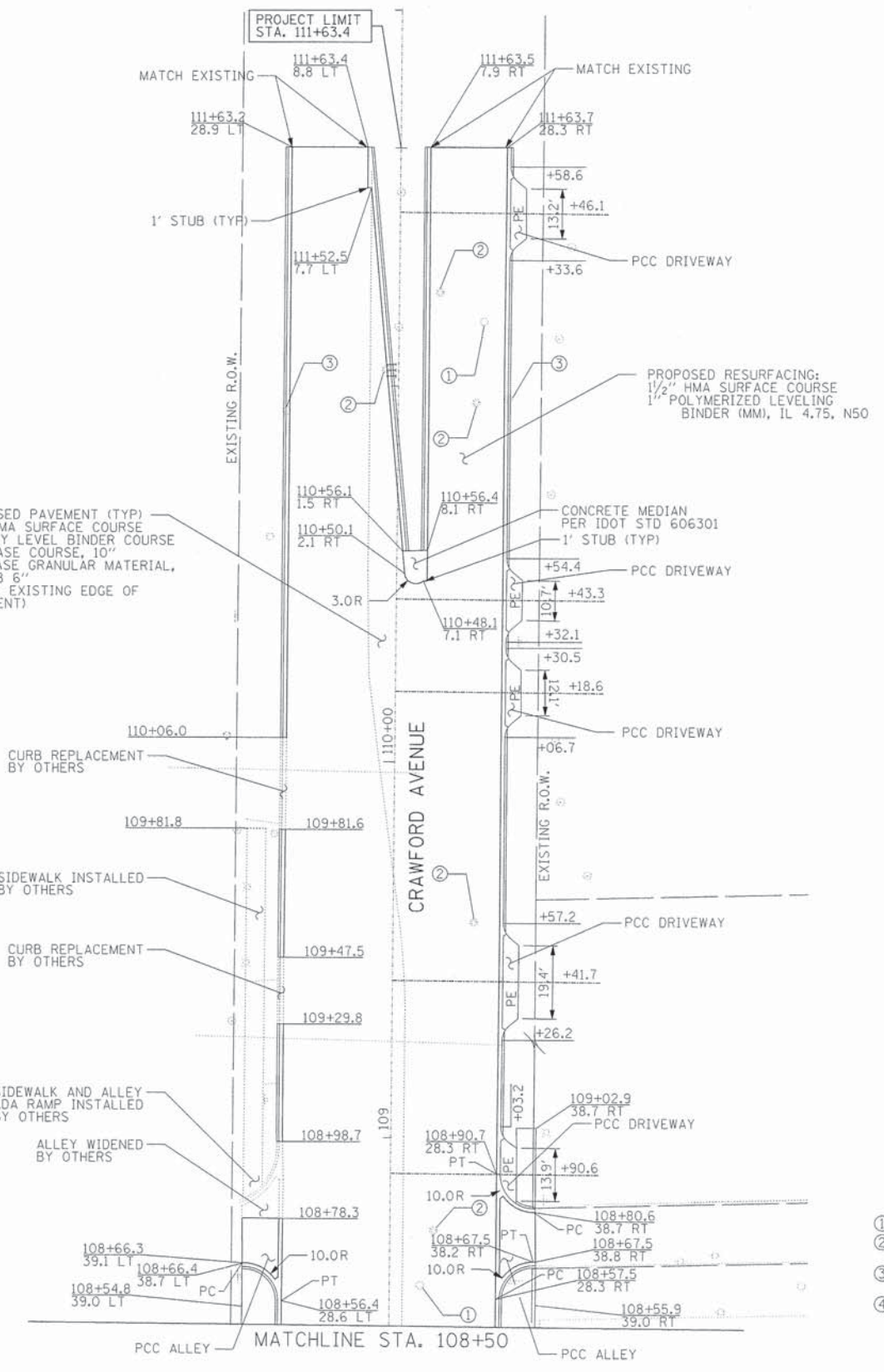
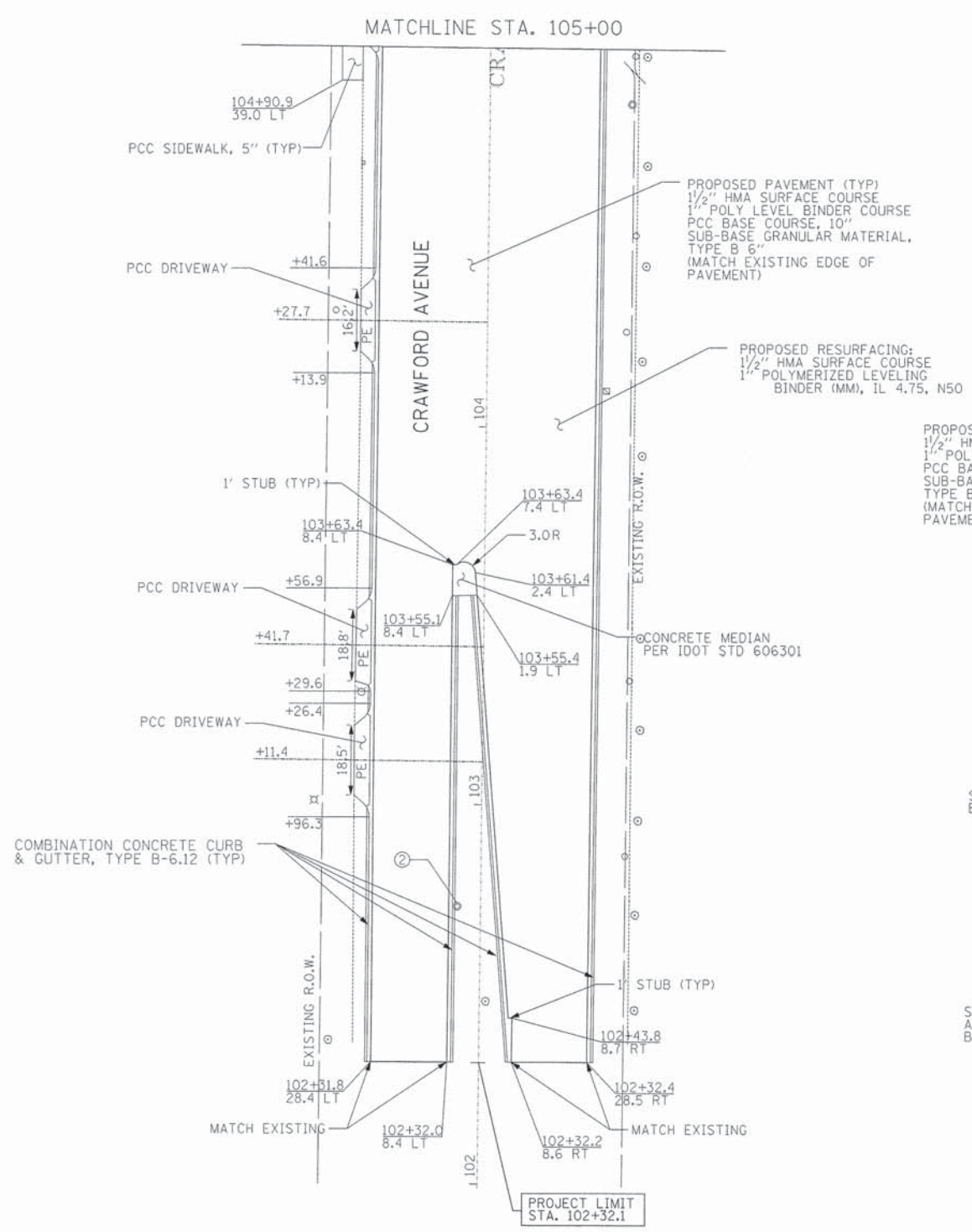

- DRAINAGE LEGEND**
- ① FRAMES AND LIDS TO BE ADJUSTED, SPECIAL
 - ② SANITARY MANHOLES FRAME AND ADJUSTMENT SEALING
 - ③ CATCH BASINS TO BE ADJUSTED WITH NEW TYPE 11 FRAME AND GRATE
 - ④ CATCH BASINS TO BE ADJUSTED WITH NEW TYPE 23 FRAME AND GRATE



TYLIN INTERNATIONAL	USER NAME - RUS214	DESIGNED - MBR	REVISED -
	PLOT SCALE - 4SCALE8	DRAWN - DM	REVISED -
	PLOT DATE - 10/17/2013	CHECKED - DBD	REVISED -
		DATE - 10/18/2013	REVISED -

**STATE OF ILLINOIS
DEPARTMENT OF TRANSPORTATION**

**INTERSECTION IMPROVEMENT
CHURCH STREET AT CRAWFORD AVENUE
PROPOSED PLAN - SHEET 2 OF 2**

SCALE: SHEET NO. OF SHEETS STA. TO STA.

F.A.U. RTE. 1313	SECTION 00-00241-00-CH	COUNTY COOK	TOTAL SHEETS 47	SHEET NO. 13
FED. ROAD DIST. NO.		ILLINOIS FED. AID PROJECT	CONTRACT NO. 63734	

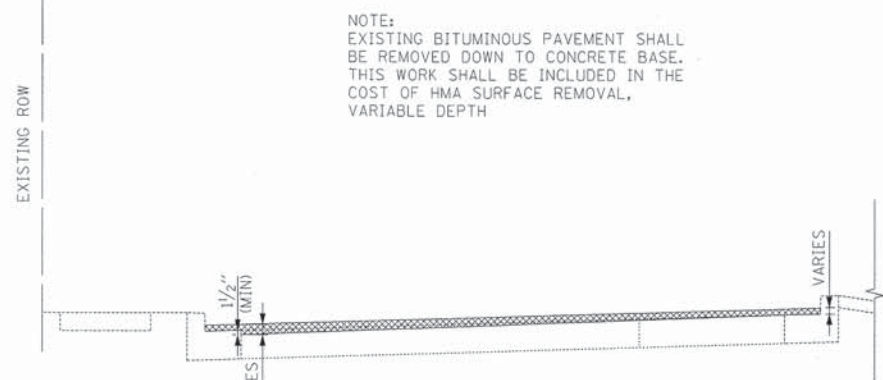

HMA SURFACE REMOVAL, VARIABLE DEPTH
CRAWFORD AVENUE

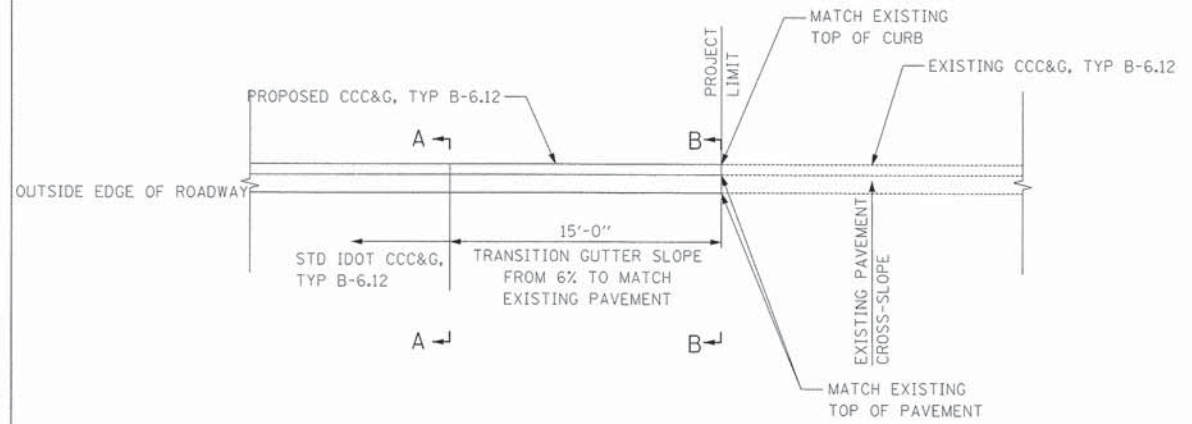

PLAN VIEW

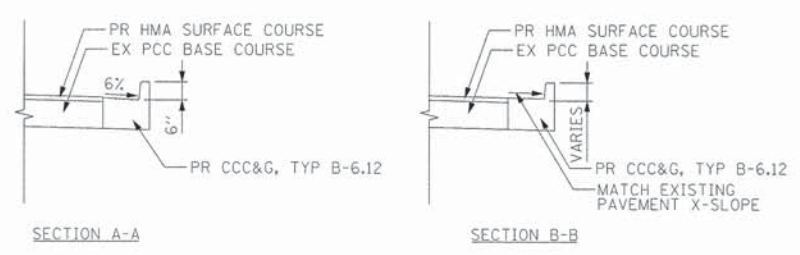

GUTTER TRANSITIONS TO
MATCH EXISTING PAVEMENT

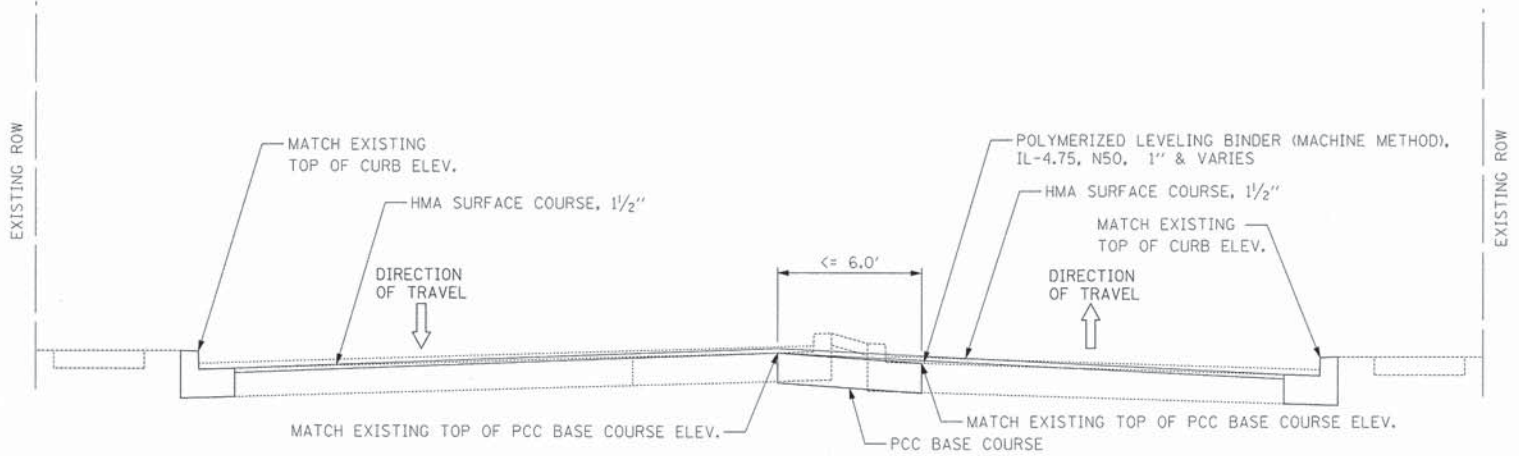

MEDIAN REPLACEMENT (<= 6') WITH
PCC BASE COURSE AND HMA SURFACE COURSE
CRAWFORD AVENUE

STA. 105+08.7 TO STA. 106+56.8
STA. 107+43.7 TO 109+34.0

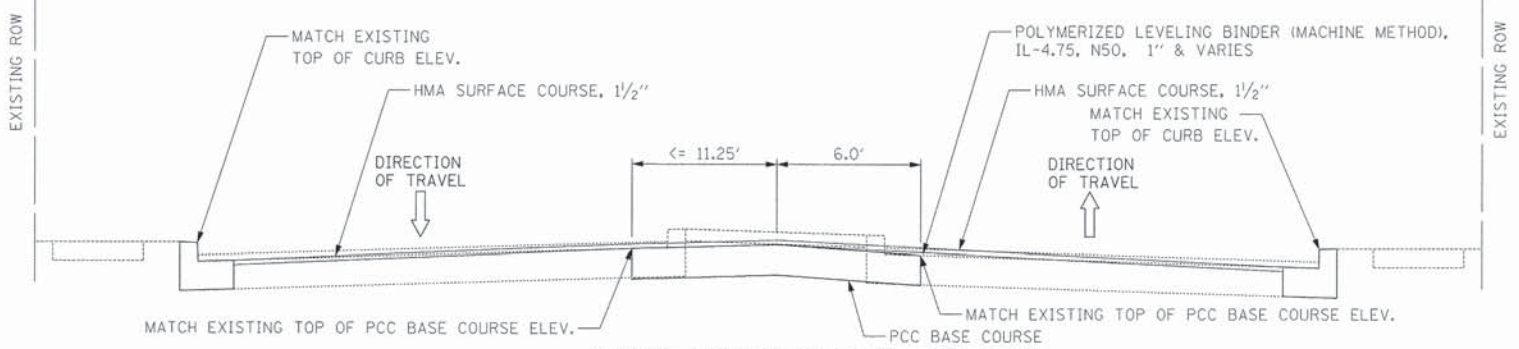

MEDIAN REPLACEMENT (>= 6') WITH
PCC BASE COURSE AND HMA SURFACE COURSE
CRAWFORD AVENUE

STA. 103+63.4 TO STA. 105+08.7
STA. 109+34.0 TO STA. 110+48.2

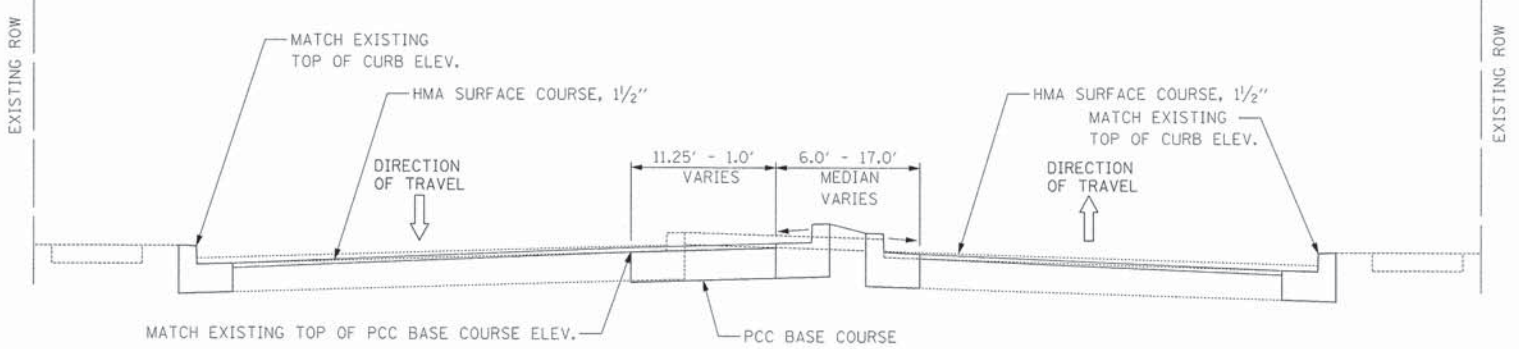

MEDIAN REPLACEMENT WITH
PCC BASE COURSE AND HMA SURFACE COURSE
CRAWFORD AVENUE

STA. 102+32.0 TO STA. 103+63.4
STA. 110+48.2 TO STA. 111+63.5

TYLIN INTERNATIONAL	USER NAME - MUSDH	DESIGNED - MBR	REVISED -
	PLOT SCALE - 4SCALE1	DRAWN -	REVISED -
	PLOT DATE - 10/17/2013	CHECKED - DBD	REVISED -
		DATE - 10/18/2013	REVISED -

STATE OF ILLINOIS
DEPARTMENT OF TRANSPORTATION

INTERSECTION IMPROVEMENT
CHURCH STREET AT CRAWFORD AVENUE
ROADWAY DETAILS

F.A.U. RTE. 1313	SECTION 00-00241-00-CH	COUNTY COOK	TOTAL SHEETS 47	SHEET NO. 14
FED. ROAD DIST. NO. [ILLINOIS] FED. AID PROJECT			CONTRACT NO. 63734	

SIGN LEGEND



R1-1
30"x30"
(FOLDABLE)



R4-7R
24"x30"



Church St
18"x60"



Crawford Av
18"x60"

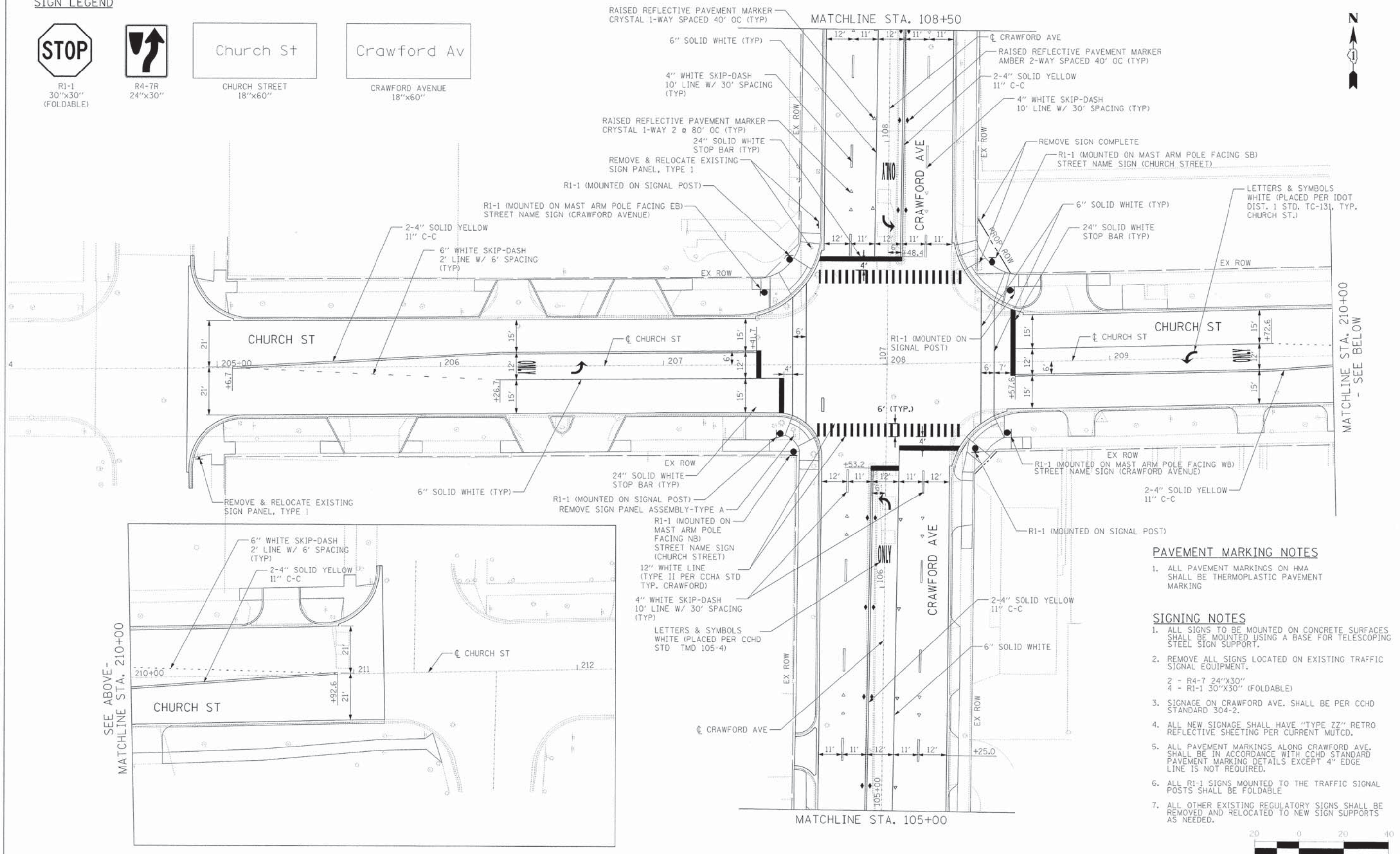

SEE ABOVE -
MATCHLINE STA. 210+00

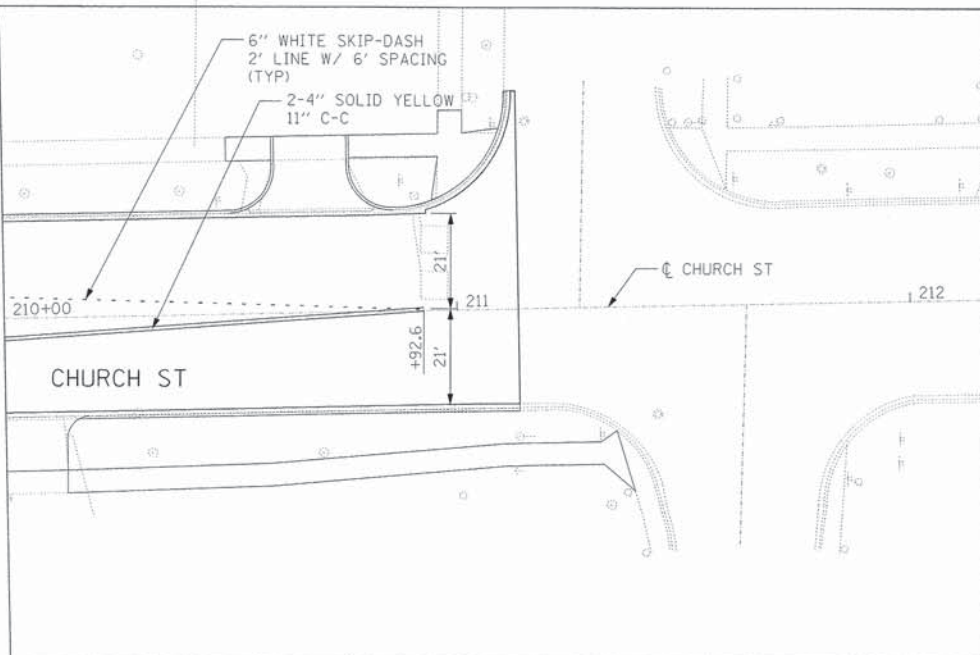

PAVEMENT MARKING NOTES

1. ALL PAVEMENT MARKINGS ON HMA SHALL BE THERMOPLASTIC PAVEMENT MARKING

SIGNING NOTES

1. ALL SIGNS TO BE MOUNTED ON CONCRETE SURFACES SHALL BE MOUNTED USING A BASE FOR TELESCOPING STEEL SIGN SUPPORT.
2. REMOVE ALL SIGNS LOCATED ON EXISTING TRAFFIC SIGNAL EQUIPMENT.
2 - R4-7 24"x30"
4 - R1-1 30"x30" (FOLDABLE)
3. SIGNAGE ON CRAWFORD AVE. SHALL BE PER CCHD STANDARD 304-2.
4. ALL NEW SIGNAGE SHALL HAVE "TYPE Z7" RETRO REFLECTIVE SHEETING PER CURRENT MUTCD.
5. ALL PAVEMENT MARKINGS ALONG CRAWFORD AVE. SHALL BE IN ACCORDANCE WITH CCHD STANDARD PAVEMENT MARKING DETAILS EXCEPT 4" EDGE LINE IS NOT REQUIRED.
6. ALL R1-1 SIGNS MOUNTED TO THE TRAFFIC SIGNAL POSTS SHALL BE FOLDABLE.
7. ALL OTHER EXISTING REGULATORY SIGNS SHALL BE REMOVED AND RELOCATED TO NEW SIGN SUPPORTS AS NEEDED.



TYLIN INTERNATIONAL P:\602558\Road\stripes\H01.dgn	DESIGNER - MBR DRAWN - CBS CHECKED - DBD DATE - 10/18/2013	REVISIONS REVISIONS REVISIONS REVISIONS
	PRIOR NAME - BUSER4 PLOT SCALE - #SCALE4 PLOT DATE - 10/26/2013	REVISIONS REVISIONS REVISIONS REVISIONS
	DESIGNED - MBR DRAWN - CBS CHECKED - DBD DATE - 10/18/2013	REVISIONS REVISIONS REVISIONS REVISIONS
	PRIOR NAME - BUSER4 PLOT SCALE - #SCALE4 PLOT DATE - 10/26/2013	REVISIONS REVISIONS REVISIONS REVISIONS

**STATE OF ILLINOIS
DEPARTMENT OF TRANSPORTATION**

INTERSECTION IMPROVEMENT CHURCH STREET AT CRAWFORD AVENUE PROPOSED PAVEMENT MARKING & SIGNING PLAN - SHEET 1 OF 2				
SCALE:	SHEET NO.	OF SHEETS	STA.	TO STA.

F.A.U. RTE.	SECTION	COUNTY	TOTAL SHEETS	SHEET NO.
1313	00-00241-00-CH	COOK	47	15
FED. ROAD DIST. NO. [ILLINOIS] FED. AID PROJECT			CONTRACT NO. 63734	



P:\602556\Road\stripes\SH02.dgn 5:54:08 PM 10/17/2013

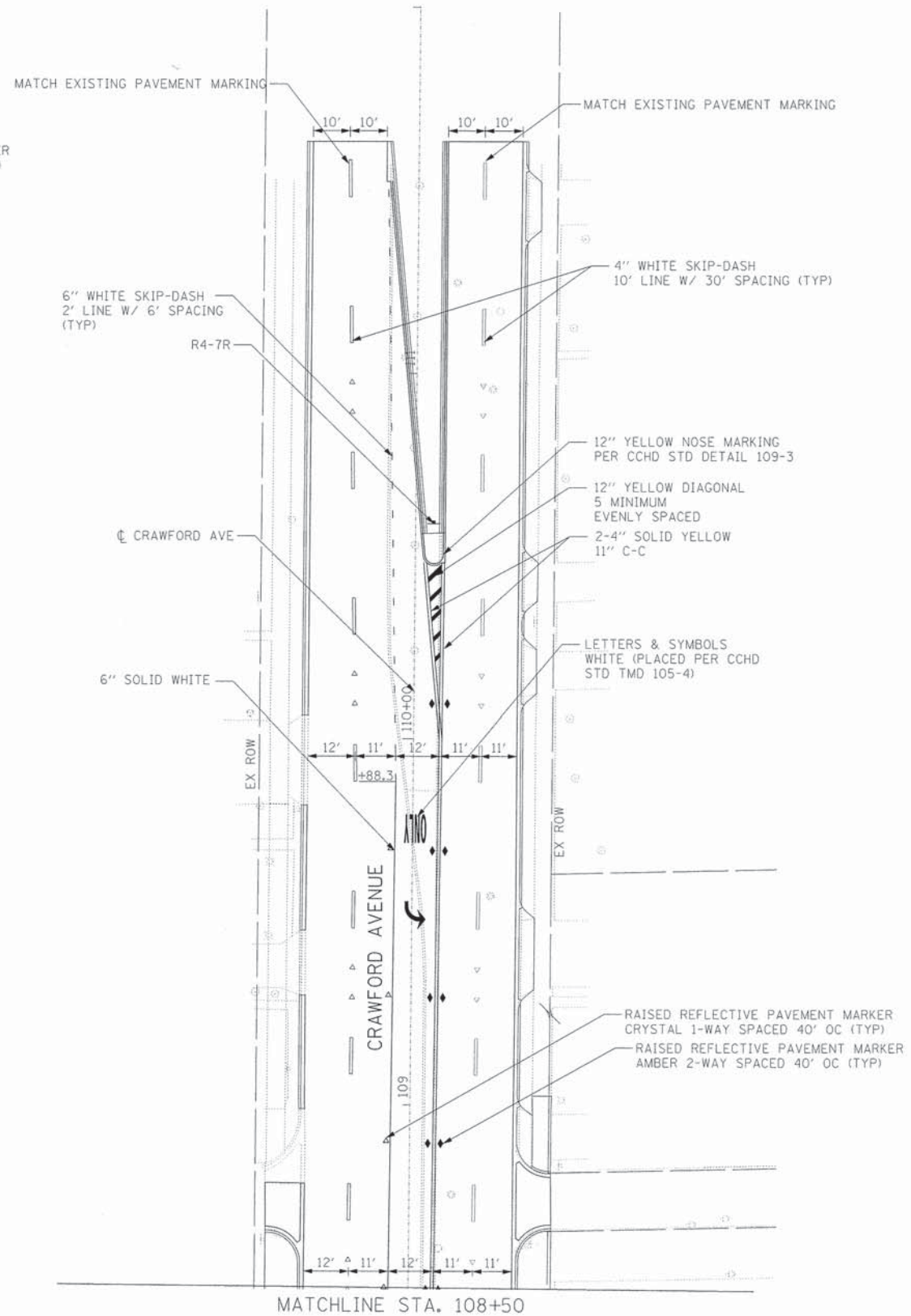
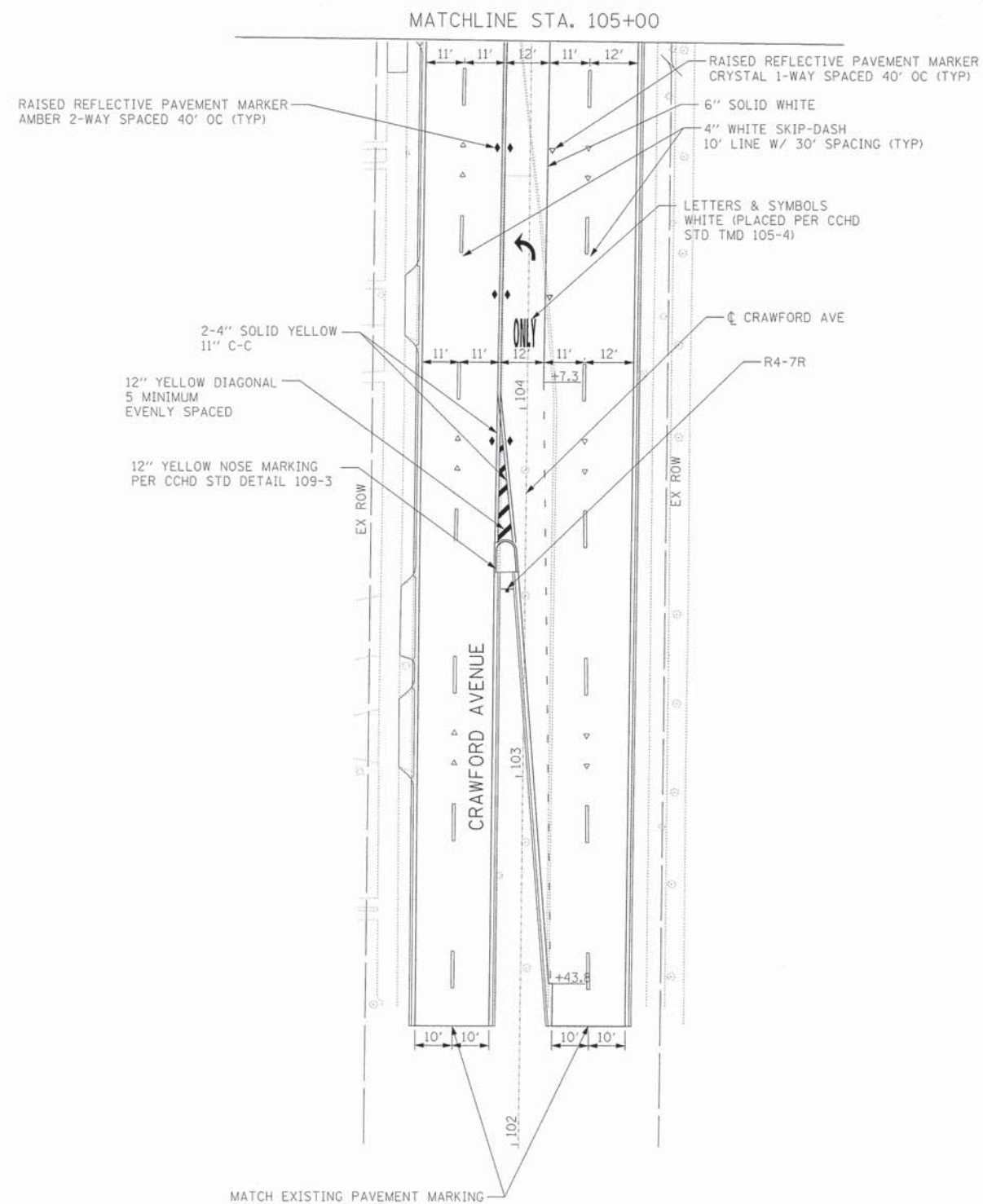

SIGN LEGEND



R4-7R
24"x30"

PAVEMENT MARKING NOTES

ALL PAVEMENT MARKINGS ON HMA SHALL BE THERMOPLASTIC PAVEMENT MARKING



TYLIN INTERNATIONAL USER NAME - MBR PLOT SCALE - 4SCALE4 PLOT DATE - 10/17/2013	DESIGNED - MBR	REVISIONS	STATE OF ILLINOIS DEPARTMENT OF TRANSPORTATION				INTERSECTION IMPROVEMENT CHURCH STREET AT CRAWFORD AVENUE PROPOSED PAVEMENT MARKING & SIGNING PLAN - SHEET 2 OF 2				F.A.U. RTE. 1313	SECTION 00-00241-00-CH	COUNTY COOK	TOTAL SHEETS 47	SHEET NO. 16			
	DRAWN - CBS	REVISIONS									SCALE: SHEET NO. OF SHEETS STA. TO STA.				CONTRACT NO. 63734			
	CHECKED - DBD	REVISIONS									FED. ROAD DIST. NO. ILLINOIS FED. AID PROJECT							
DATE - 10/18/2013	REVISIONS																	

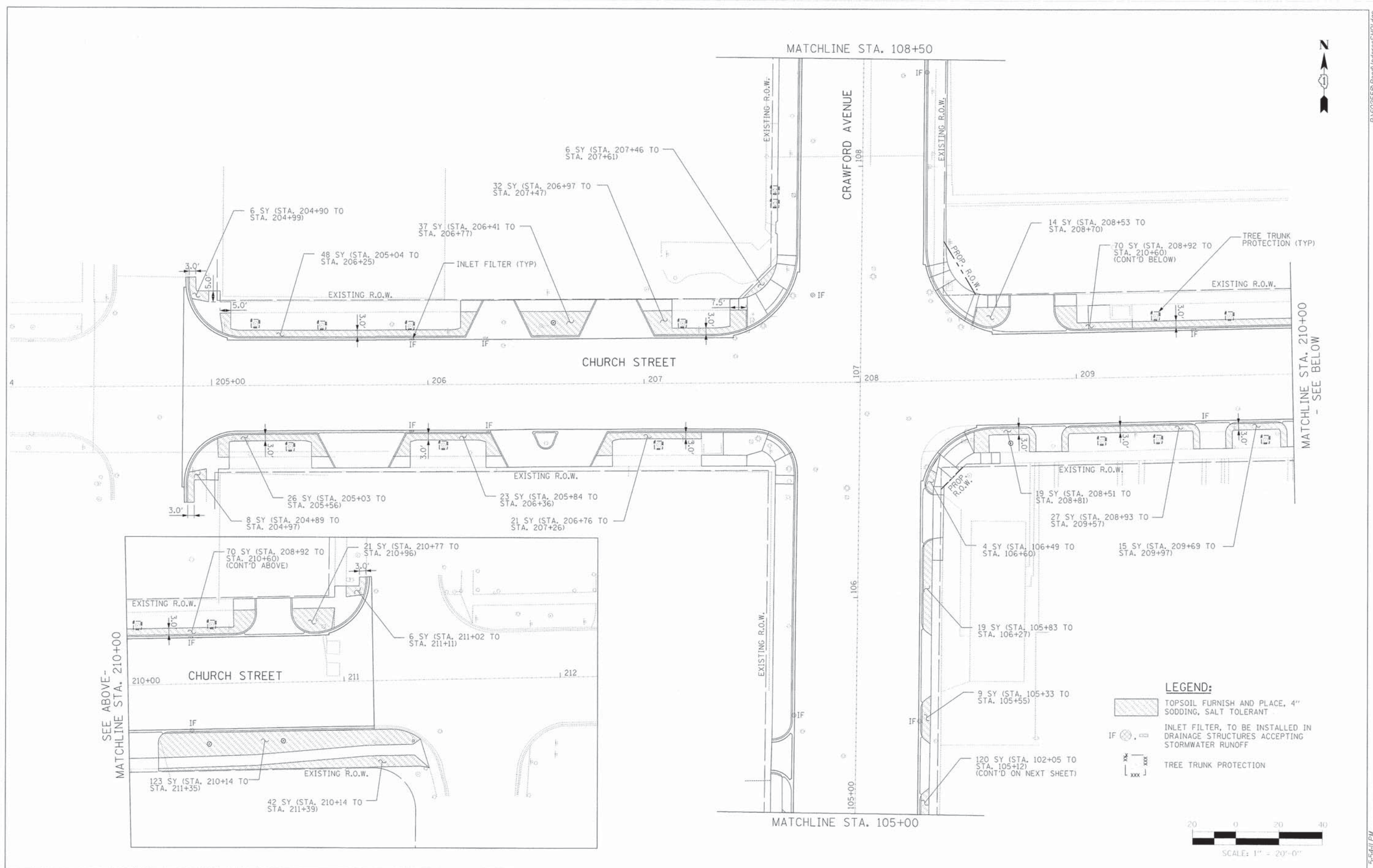

TYLIN INTERNATIONAL

USER NAME = BUSER9	DESIGNED - MBR	REVISED -
PL01 SCALE = 1/4"=1'-0"	DRAWN - DM	REVISED -
PL01 DATE = 10/17/2013	CHECKED - DBD	REVISED -
	DATE - 10/18/2013	REVISED -

**STATE OF ILLINOIS
DEPARTMENT OF TRANSPORTATION**

**INTERSECTION IMPROVEMENT
CHURCH STREET AT CRAWFORD AVENUE
PROPOSED LANDSCAPING AND EROSION CONTROL PLAN - SHEET 1 OF 2**

F.A.U. RTE. 1313	SECTION 00-00241-00-CH	COUNTY COOK	TOTAL SHEETS 47	SHEET NO. 17
FED. ROAD DIST. NO.		ILLINOIS FED. AID PROJECT CONTRACT NO. 63734		



P:\602558\Road\Underos5H02.dgn

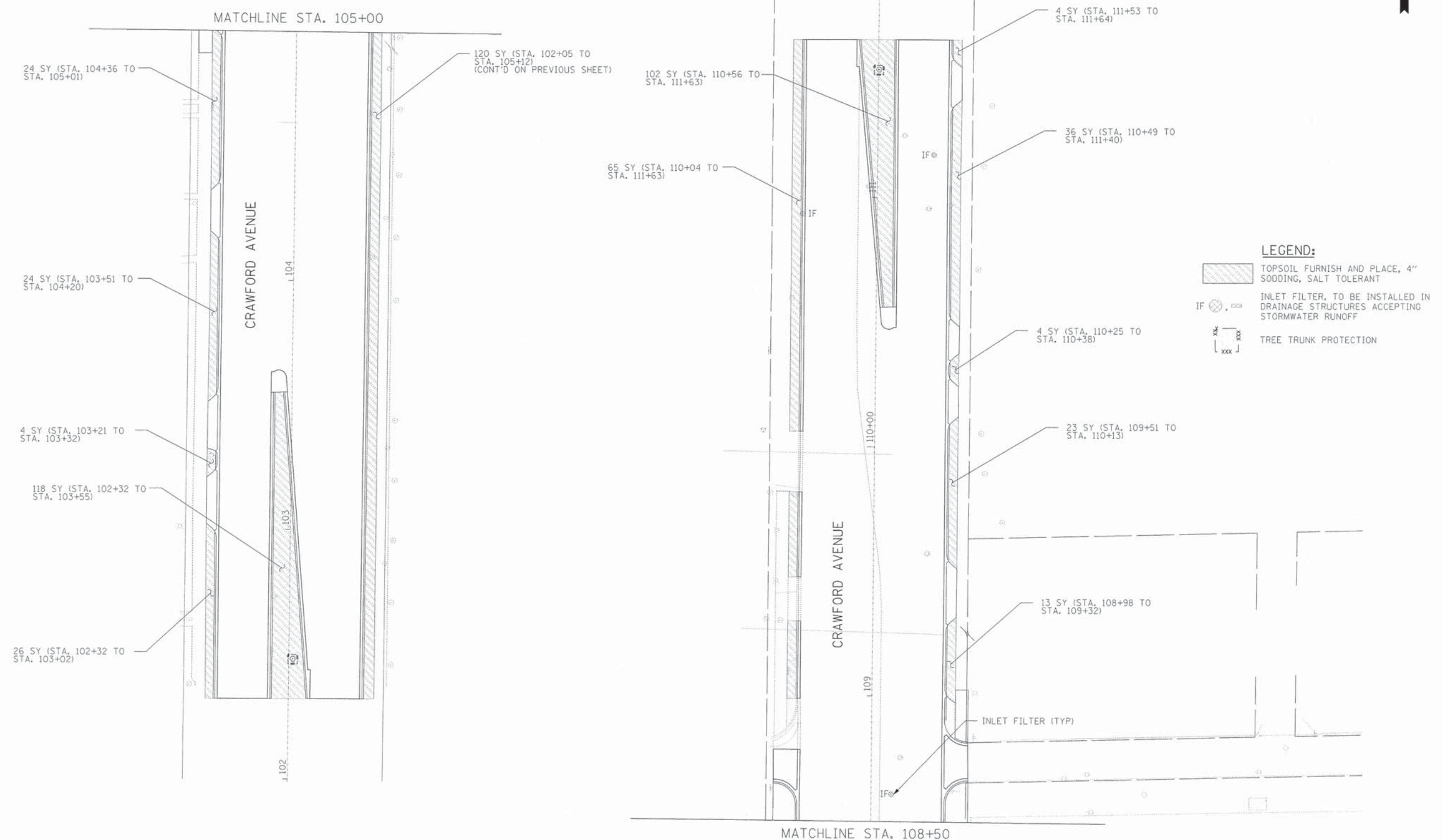

TYLIN INTERNATIONAL	USER NAME - RWSEH	DESIGNED - MBR	REVISED -
	PLOT SCALE - 4SCALEP	DRAWN - DM	REVISED -
	PLOT DATE - 10/17/2013	CHECKED - DBD	REVISED -
		DATE - 10/18/2013	REVISED -

**STATE OF ILLINOIS
DEPARTMENT OF TRANSPORTATION**

**INTERSECTION IMPROVEMENT
CHURCH STREET AT CRAWFORD AVENUE
PROPOSED LANDSCAPING AND EROSION CONTROL PLAN - SHEET 2 OF 2**

F.A.U. RTE. 1313	SECTION 00-00241-00-CH	COUNTY COOK	TOTAL SHEETS 47	SHEET NO. 18
FED. ROAD DIST. NO. ILLINOIS FED. AID PROJECT			CONTRACT NO. 63734	

P:\602558\Road\Underos5H02.dgn

10/17/2013 5:54:14 PM



NOTES:

1. THE LOCATIONS AND LENGTHS OF THE EXISTING SYSTEM ARE BASED ON PRE-BUILT PLANS AND TOPOGRAPHICAL INFORMATION AND SHOULD BE CONSIDERED APPROXIMATE.

GENERAL NOTES FOR TEMPORARY TRAFFIC SIGNALS

1. ALL CONTROL EQUIPMENT INCLUDING EMERGENCY PRE-EMPTION AND COMMUNICATION DEVICES FOR THE TEMPORARY TRAFFIC (S) SHALL BE FURNISHED BY THE CONTRACTOR.
2. ONLY CONTROLLERS SUPPLIED BY ONE THE DISTRICT APPROVED CLOSED LOOP EQUIPMENT MANUFACTURERS WILL BE APPROVED FOR USE AT TEMPORARY SIGNAL LOCATIONS. ALL CONTROLLERS USED FOR TEMPORARY TRAFFIC SIGNALS SHALL BE FULLY ACTUATED NEMA MICROPROCESSOR BASED WITH RS232 DATA ENTRY PORTS COMPATIBLE WITH EXISTING MONITORING SOFTWARE APPROVED BY IDOT DISTRICT 1, INSTALLED IN A NEMA TS2 CABINET. ONLY ONE BRAND OF CONTROLLER WILL BE ACCEPTED FOR ANY ONE CONTRACT.
3. ALL TRAFFIC SIGNAL SECTIONS AND PEDESTRIAN SIGNAL SECTIONS SHALL BE LED AND 12" (300mm) DIAMETER. HEADS SHALL BE PLACED AS INDICATED ON THE TEMPORARY TRAFFIC SIGNAL PLANS OR AS DIRECTED BY THE ENGINEER. PEDESTRIAN SIGNALS SHALL INCLUDE SOLID INTERNATIONAL SYMBOLS. PEDESTRIAN SIGNALS WITH COUNTDOWN TIMERS SHALL BE USED WHEN THE EXISTING INSTALLATION UTILIZES COUNTDOWN TYPE OR AS DIRECTED BY THE ENGINEER. COUNTDOWN TYPE PEDESTRIAN SIGNALS ARE NOT TO BE INSTALLED AT A RAILROAD INTERSECTION. THE CONTRACTOR SHALL FURNISH ENOUGH CABLE SLACK TO RELOCATE HEADS TO ANY POSITION ON THE SPAN WIRE OR AT LOCATIONS ILLUSTRATED ON THE PLANS FOR CONSTRUCTION STAGING. THE TEMPORARY TRAFFIC SIGNAL SHALL REMAIN IN OPERATION DURING ALL SIGNAL HEAD RELOCATIONS. EACH TEMPORARY TRAFFIC SIGNAL HEAD SHALL HAVE ITS OWN CABLE FROM THE CONTROLLER CABINET TO THE SIGNAL HEAD.
4. ALL EXISTING STREET NAME AND INTERSECTION REGULATORY SIGNS SHALL BE REMOVED FROM EXISTING POLES, RELOCATED AND SECURELY FASTENED TO THE SPAN WIRE OR WOOD POLE AS DIRECTED BY THE ENGINEER.
5. ANY TEMPORARY SIGNAL WITHIN AN EXISTING CLOSED LOOP TRAFFIC SIGNAL SYSTEM SHALL BE INTERCONNECTED TO THAT SYSTEM USING SIMILAR BRAND CONTROL EQUIPMENT.
6. THE TEMPORARY TRAFFIC SIGNAL SHALL HAVE THE SIGNAL HEAD DISPLAYS, SIGNAL HEAD PLACEMENTS AND CONTROLLER PHASING MATCH THE EXISTING TRAFFIC SIGNAL, AT THE TIME OF TURN ON, IF NO TRAFFIC STAGING IS IN PLACE OR WILL NOT BE STAGED ON THE DAY OF THE TURN ON.
7. UNINTERRUPTIBLE POWER SUPPLY (UPS) SYSTEMS SHALL BE INSTALLED AND MADE OPERATIONAL AT TEMPORARY TRAFFIC SIGNAL INSTALLATIONS WHERE UPS IS INSTALLED AT THE EXISTING TRAFFIC SIGNAL, TEMPORARY TRAFFIC SIGNALS AT RAILROAD INTERSECTIONS, AND TEMPORARY TRAFFIC SIGNALS AT INTERSECTIONS WITH FIRE STATION ACTUATED EMERGENCY VEHICLE PRE-EMPTION, OR WHEN INDICATED ON THE PLANS.
8. TRAFFIC SIGNAL MANAGEMENT SYSTEMS SHALL BE MAINTAINED IN OPERATION AS INDICATED ON THE PLANS OR AS DIRECTED BY THE ENGINEER. REQUIRED EQUIPMENT SHALL BE AS SHOWN ON THE PLANS AND THE CONTRACTOR SHALL PLACE THE EQUIPMENT IN OPERATION TO THE SATISFACTION OF THE ENGINEER AND THE AGENCY RESPONSIBLE FOR THE TRAFFIC SIGNAL MANAGEMENT SYSTEM.
9. DETECTION AT TEMPORARY TRAFFIC SIGNALS SHALL BE INCLUDED FOR ALL APPROACHES OF THE INTERSECTION UNLESS INDICATED OTHERWISE ON THE PLANS. THE DETECTION SYSTEM MUST MEET THE SPECIFICATIONS OF DISTRICT 1 AND THE CONTRACTOR SHALL PLACE THE DETECTORS INTO OPERATION TO THE SATISFACTION OF THE ENGINEER.
10. WHEN PAN, TILT, ZOOM CAMERAS ARE INSTALLED AT THE EXISTING INTERSECTION OR ARE CALLED FOR IN THE PLANS, THE CONTRACTOR SHALL BE RESPONSIBLE FOR INSTALLING AND MAINTAINING THE CAMERAS TO THE SATISFACTION OF THE ENGINEER AND THE AGENCY RESPONSIBLE FOR THE CAMERAS.

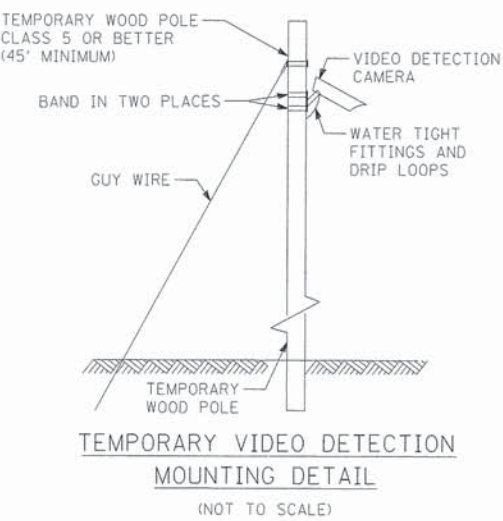

TEMPORARY SIGNAL REMOVAL NOTES:

THE FOLLOWING ITEMS SHALL BE REMOVED BY THE CONTRACTOR AND SHALL BE DISPOSED OF BY THEM OUTSIDE SIDE THE RIGHT-OF-WAY AT THEIR EXPENSE. THE SALVAGE VALUE OF THE REMOVED EQUIPMENT SHALL BE REFLECTED IN THE CONTRACT BID PRICE.

- 1 EACH TRAFFIC SIGNAL CONTROLLER AND CABINET
- 10 EACH SIGNAL POST
- 7 EACH HANDHOLE
- 8 EACH SIGNAL HEAD, 1-FACE, 3-SECTION
- 4 EACH SIGNAL HEAD, 1-FACE, 5-SECTION
- 1 LSUM EXISTING TRAFFIC SIGNAL CABLING

RESTORATION OF WORK AREA: RESTORATION OF THE TRAFFIC SIGNAL WORK AREA SHALL BE INCIDENTAL TO THE RELATED PAY ITEM SUCH AS FOUNDATION, CONDUIT, HANDHOLE, TRENCH AND BACKFILL, ETC., AND NO EXTRA COMPENSATION SHALL BE ALLOWED. ALL ROADWAY SURFACES SUCH AS SHOULDERS, MEDIANS, SIDEWALKS, PAVEMENT, ETC., SHALL BE REPLACED IN KIND. ALL DAMAGE TO UNMOWED FIELDS SHALL BE SEEDDED IN ACCORDANCE WITH STANDARD SPECIFICATIONS 252 AND 250 RESPECTIVELY.



TYLIN INTERNATIONAL USER NAME : USER1 PLOT SCALE : 1/4"=1'-0" PLOT DATE : 10/28/2013	DESIGNED - MBR	REVISED -	STATE OF ILLINOIS DEPARTMENT OF TRANSPORTATION	INTERSECTION IMPROVEMENT CHURCH STREET AT CRAWFORD AVENUE TEMPORARY TRAFFIC SIGNAL INSTALLATION AND REMOVAL				F.A.U. RTE. 1313	SECTION 00-00241-00-CH	COUNTY COOK	TOTAL SHEETS 47	SHEET NO. 19
	DRAWN -	REVISED -		SCALE: SHEET NO. OF SHEETS STA. TO STA.				CONTRACT NO. 63734				
	CHECKED - DBD	REVISED -						FED. ROAD DIST. NO. [ILLINOIS] FED. AID PROJECT				
DATE - 10/18/2013	REVISED -											

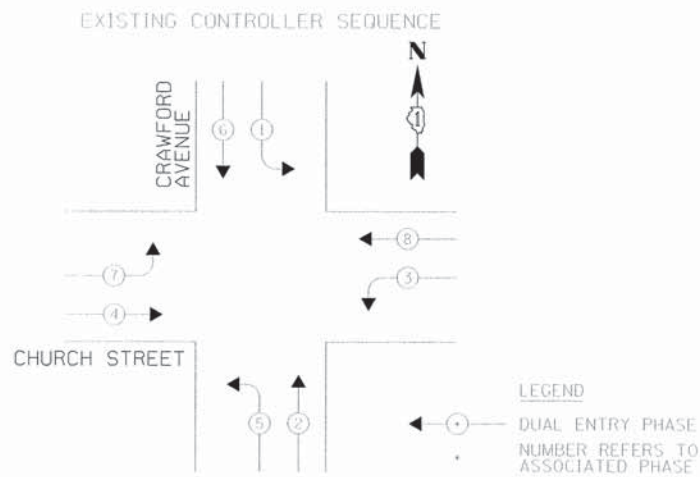

EXISTING PHASE DESIGNATION DIAGRAM

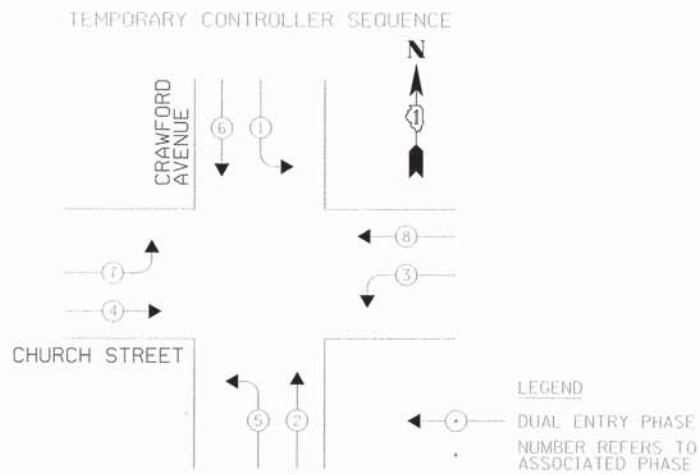

TEMPORARY PHASE DESIGNATION DIAGRAM

I.D.O.T. TRAFFIC SIGNAL INSTALLATION ELECTRICAL SERVICE REQUIREMENTS					TOTAL WATTAGE
TYPE	NO. OF LAMPS	WATTAGE		% OPERATION	
SIGNAL (RED)	12	INCAND.	LED	0.50	102.00
(YELLOW)	12			0.25	75.00
(GREEN)	12			0.25	45.00
ARROW	16			0.10	19.20
RED SIGNAL	--			1.00	--
CONTROLLER	1			1.00	100.00
ILLUM. SIGN	--			0.05	--
VIDEO SYSTEM	1	150		1.00	150.00
FLASHER					
ENERGY COSTS TO:				TOTAL:	491.20

VILLAGE OF SKOKIE
 5127 LAWTON STREET
 SKOKIE, IL 60077

ENERGY SUPPLY CONTACT: LARRY SWANE
 PHONE: 847.016.5465
 CURVING: COBED

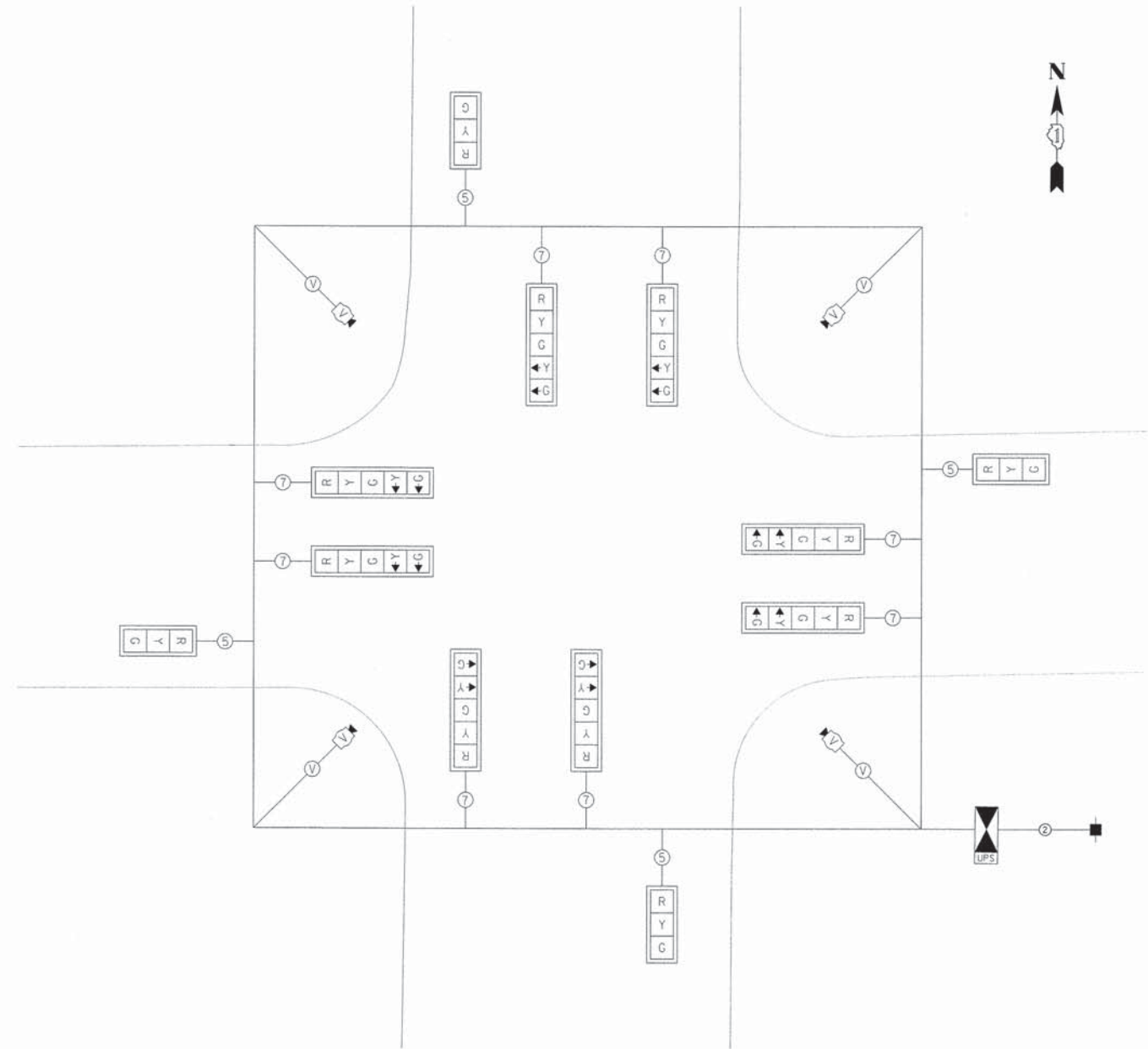

TEMPORARY CABLE PLAN

RESTORATION OF WORK AREA, RESTORATION OF THE TRAFFIC SIGNAL WORK AREA SHALL BE INCIDENTAL TO THE RELATED PAY ITEM SUCH AS FOUNDATION, CONDUIT, HANDHOLE, TRENCH AND BACKFILL, ETC., AND NO EXTRA COMPENSATION SHALL BE ALLOWED. ALL ROADWAY SURFACES SUCH AS SHOULDERS, MEDIANS, SIDEWALKS, PAVEMENT, ETC. SHALL BE REPLACED IN KIND. ALL DAMAGE TO MOWED LAWNS SHALL BE REPLACED WITH AN APPROVED SOD.

TYLIN INTERNATIONAL	USER NAME = BUSENS	DESIGNED = MBR	REVISED =
	PLOT SCALE = 45/SCALE	DRAWN =	REVISED =
	PLOT DATE = 10/17/2013	CHECKED = DBD	REVISED =
		DATE = 10/18/2013	REVISED =

STATE OF ILLINOIS
 DEPARTMENT OF TRANSPORTATION

INTERSECTION IMPROVEMENT
 CHURCH STREET AT CRAWFORD AVENUE
 TEMPORARY CABLE PLAN

SCALE: N.T.S. SHEET NO. OF SHEETS STA. TO STA.

F.A.U. RTE. 1313	SECTION 00-00241-00-CH	COUNTY COOK	TOTAL SHEETS 47	SHEET NO. 20
FED. ROAD DIST. NO.		ILLINOIS FED. AID PROJECT		
CONTRACT NO. 63734				

NOTE:

THE GENERAL CONTRACTOR IS REQUIRED TO HIRE AN ENVIRONMENTAL FIRM WITH AT LEAST FIVE (5) DOCUMENTED LEAKING UNDERGROUND STORAGE TANK CLEAN-UPS OR THAT IS PRE-QUALIFIED IN HAZARDOUS WASTE BY THE DEPARTMENT TO REMEDIATE THE SOIL CONTAMINATION AND MONITOR FOR WORKER PROTECTION. THIS FIRM WILL BE REQUIRED TO CONTINUOUSLY MONITOR FOR WORKER SAFETY AND SOIL CONTAMINATION AT SEVERAL LOCATIONS. SEE SPECIAL PROVISIONS AND SUPPLEMENTAL SPECIFICATIONS FOR DETAILS.

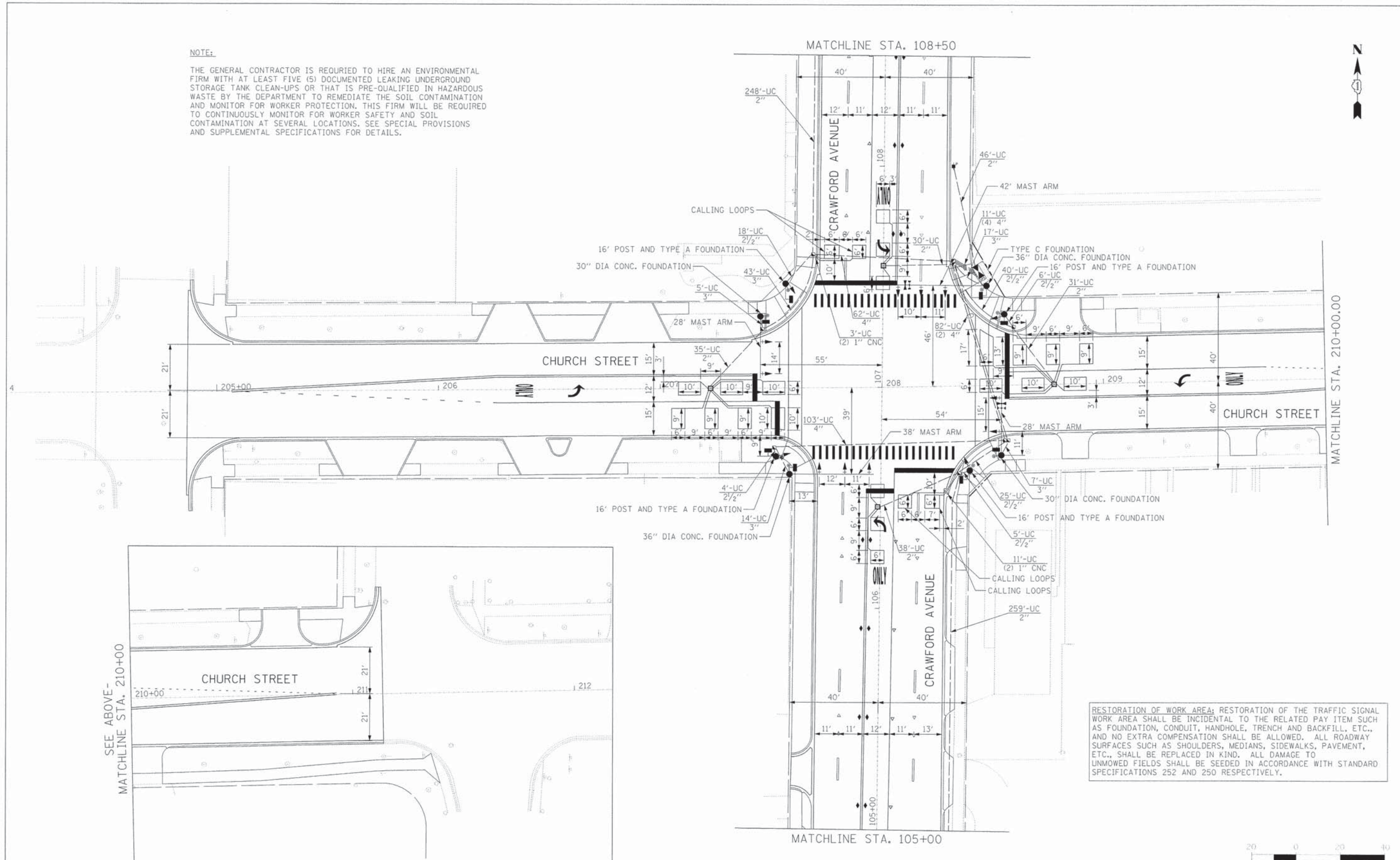

SEE ABOVE -
MATCHLINE STA. 210+00

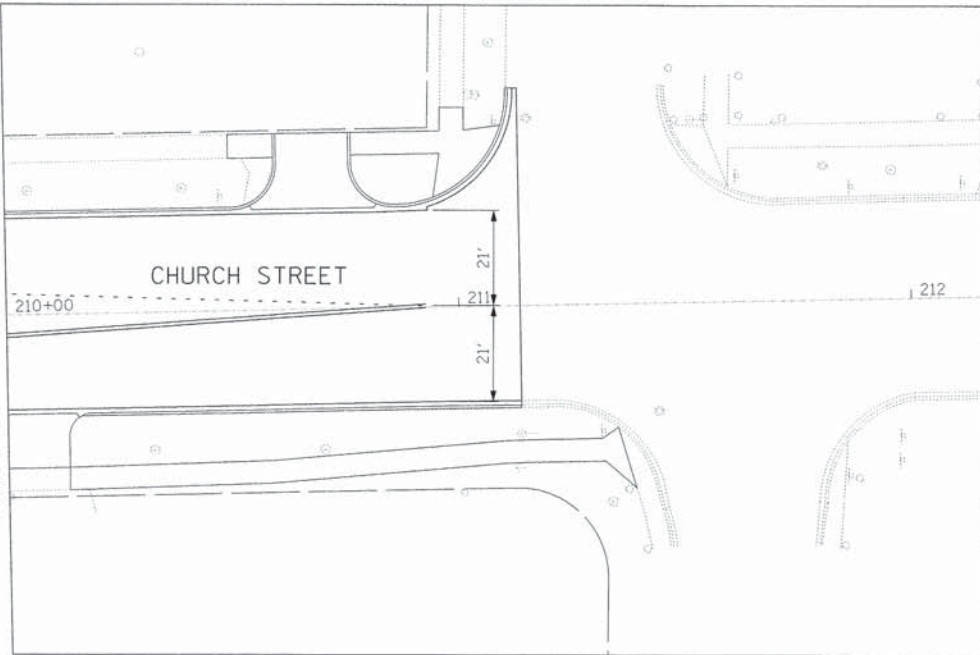

RESTORATION OF WORK AREA: RESTORATION OF THE TRAFFIC SIGNAL WORK AREA SHALL BE INCIDENTAL TO THE RELATED PAY ITEM SUCH AS FOUNDATION, CONDUIT, HANDHOLE, TRENCH AND BACKFILL, ETC., AND NO EXTRA COMPENSATION SHALL BE ALLOWED. ALL ROADWAY SURFACES SUCH AS SHOULDERS, MEDIANS, SIDEWALKS, PAVEMENT, ETC., SHALL BE REPLACED IN KIND. ALL DAMAGE TO UNMOWED FIELDS SHALL BE SEED IN ACCORDANCE WITH STANDARD SPECIFICATIONS 252 AND 250 RESPECTIVELY.



TYLIN INTERNATIONAL	USER NAME - RUSERR	DESIGNED - MBR	REVISED -
	PLOT SCALE - 4SCALE4	DRAWN -	REVISED -
	PLOT DATE - 10/17/2013	CHECKED - DBD	REVISED -
		DATE - 10/18/2013	REVISED -

**STATE OF ILLINOIS
DEPARTMENT OF TRANSPORTATION**

**INTERSECTION IMPROVEMENT
CHURCH STREET AT CRAWFORD AVENUE
TRAFFIC SIGNAL IMPROVEMENT PLANS - SHEET 1 OF 3**

F.A.U. RTE. 1313	SECTION 00-00241-00-CH	COUNTY COOK	TOTAL SHEETS 47	SHEET NO. 21
FED. ROAD DIST. NO. ILLINOIS		CONTRACT NO. 63734		
FED. AID PROJECT				

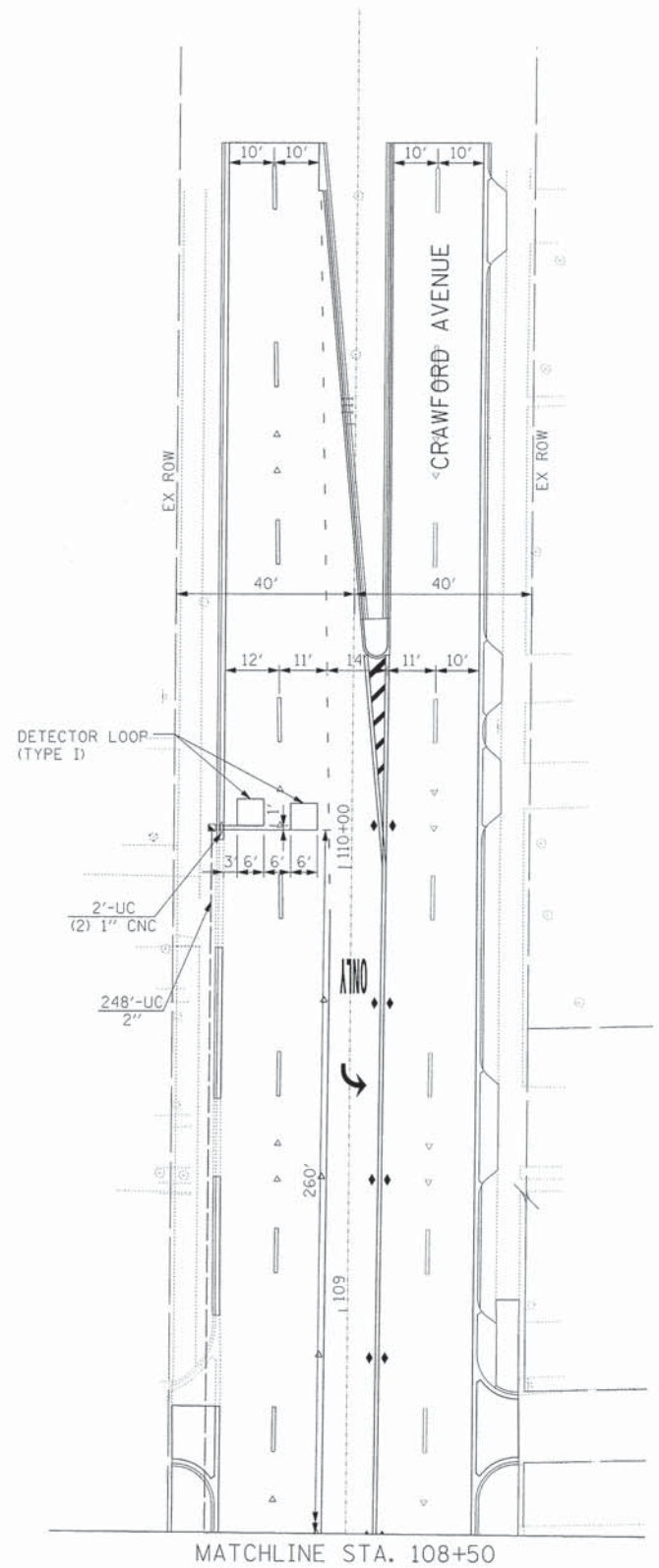
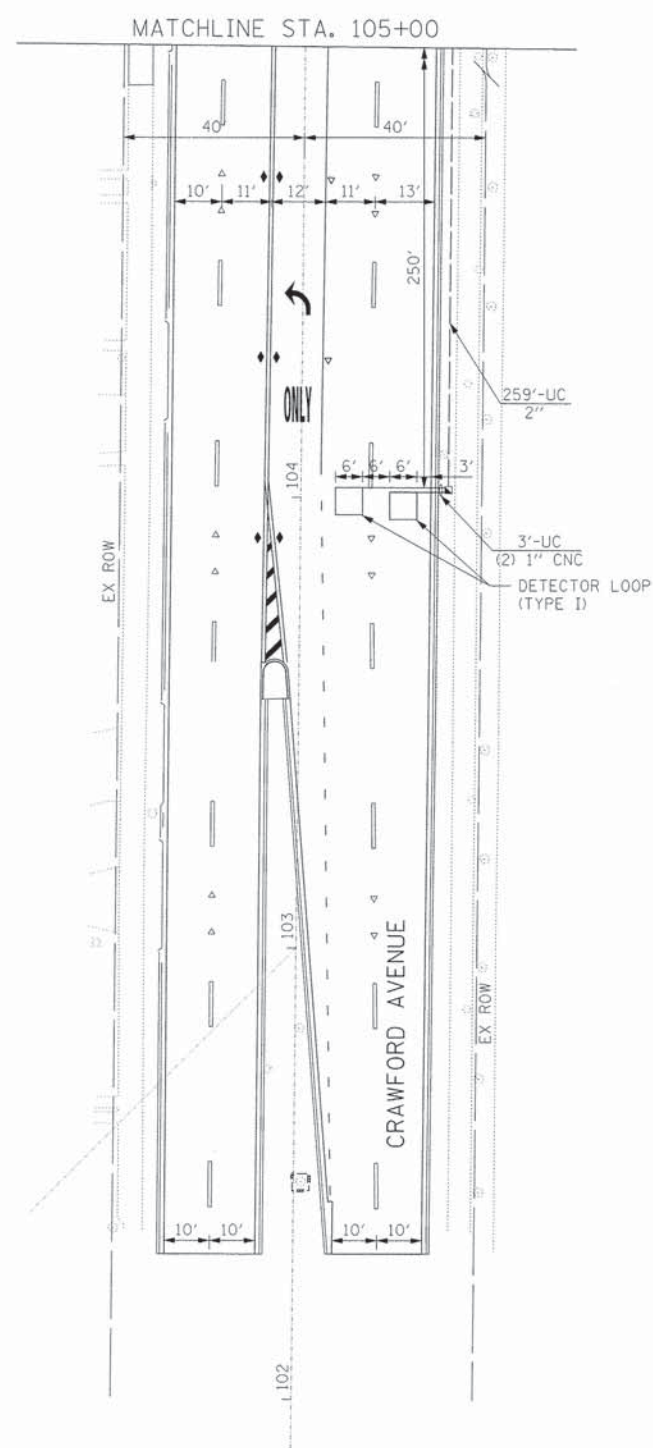

TYLIN INTERNATIONAL	USER NAME - 405049	DESIGNED - MBR	REVISED -
	PLOT SCALE - 4SCALE4	DRAWN -	REVISED -
	PLOT DATE - 10/17/2013	CHECKED - DBD	REVISED -
		DATE - 10/18/2013	REVISED -

**STATE OF ILLINOIS
DEPARTMENT OF TRANSPORTATION**

**INTERSECTION IMPROVEMENT
CHURCH STREET AT CRAWFORD AVENUE
TRAFFIC SIGNAL IMPROVEMENT PLANS - SHEET 2 OF 3**

SCALE: SHEET NO. OF SHEETS STA. TO STA.

F.A.U. RTE. 1313	SECTION 00-00241-00-CH	COUNTY COOK	TOTAL SHEETS 47	SHEET NO. 22
FED. ROAD DIST. NO.		ILLINOIS FED. AID PROJECT		
		CONTRACT NO. 63734		

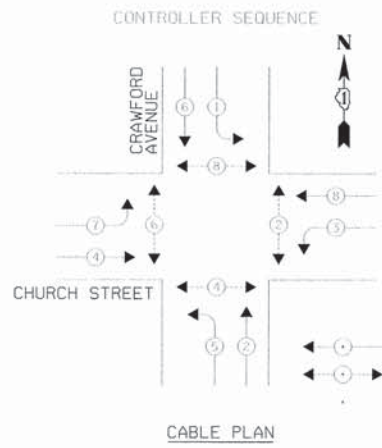

LEGEND
 DUAL ENTRY PHASE
 PEDESTRIAN PHASE
 NUMBER REFERS TO ASSOCIATED PHASE

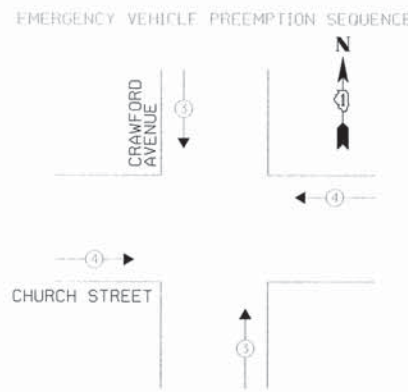

PROPOSED EMERGENCY VEHICLE PREEMPTION			
EMERGENCY VEHICLE PREEMPTOR	3	4	
MOVEMENT	↓	←	→

I.D.O.T. TRAFFIC SIGNAL INSTALLATION ELECTRICAL SERVICE REQUIREMENTS					TOTAL WATTAGE
TYPE	NO. OF LAMPS	WATTAGE		% OPERATION	
SIGNAL (RED)	14	INCAND.	LED	0.50	117.00
(YELLOW)	14			0.25	62.50
(GREEN)	14			0.25	37.50
ARROW	16			0.10	14.20
PED. SIGNAL	8			1.00	200.00
CONTROLLER	1			1.00	100.00
ILLUM. SIGN	—			0.05	—
FLASHER					
ENERGY COSTS TO:					TOTAL: 538.20

VILLAGE OF SKOKIE
 5127 OAKTON STREET
 SKOKIE, IL 60077
 ADDRESS LINE 3
 ENERGY SUPPLY CONTACT: LOBBY SHAW
 PHONE: 847.516.5465
 COMPANY: TIBED

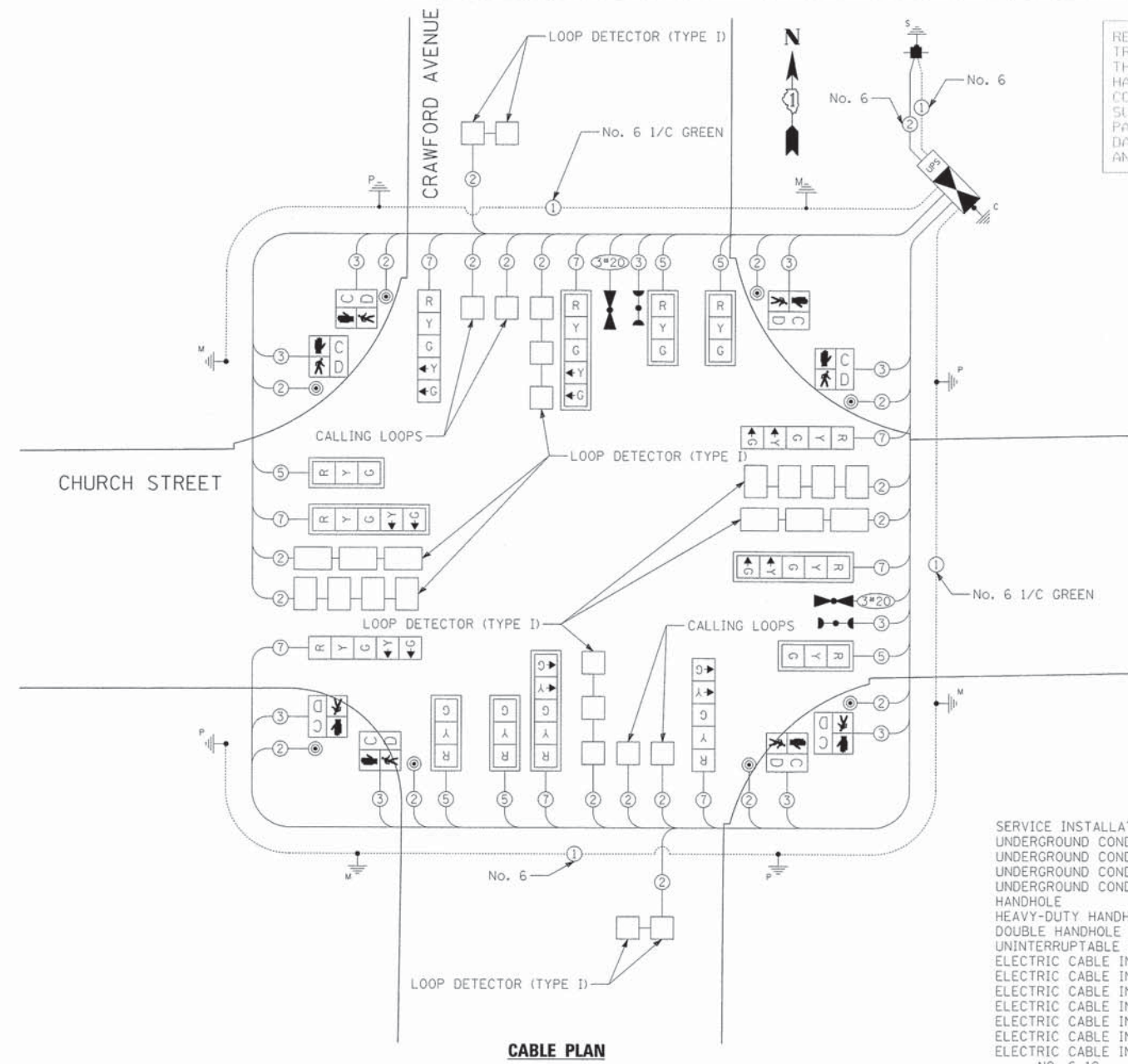

RESTORATION OF WORK AREA, RESTORATION OF THE TRAFFIC SIGNAL WORK AREA SHALL BE INCIDENTAL TO THE RELATED PAY ITEM SUCH AS FOUNDATION, CONDUIT, HANDHOLE, TRENCH AND BACKFILL, ETC., AND NO EXTRA COMPENSATION SHALL BE ALLOWED. ALL ROADWAY SURFACES SUCH AS SHOULDERS, MEDIANS, SIDEWALKS, PAVEMENT, ETC. SHALL BE REPLACED IN KIND. ALL DAMAGE TO MOWED LAWNS SHALL BE REPLACED WITH AN APPROVED SOD.

SCHEDULE OF QUANTITIES

SERVICE INSTALLATION - POLE MOUNTED	EACH	1
UNDERGROUND CONDUIT, GALVANIZED STEEL, 2" DIA.	FOOT	675
UNDERGROUND CONDUIT, GALVANIZED STEEL, 2 1/2" DIA.	FOOT	111
UNDERGROUND CONDUIT, GALVANIZED STEEL, 3" DIA.	FOOT	73
UNDERGROUND CONDUIT, GALVANIZED STEEL, 4" DIA.	FOOT	311
HANDHOLE	EACH	7
HEAVY-DUTY HANDHOLE	EACH	4
DOUBLE HANDHOLE	EACH	2
UNINTERRUPTABLE POWER SUPPLY, SPECIAL	EACH	1
ELECTRIC CABLE IN CONDUIT, SIGNAL NO. 14 2C	FOOT	1228
ELECTRIC CABLE IN CONDUIT, SIGNAL NO. 14 3C	FOOT	1569
ELECTRIC CABLE IN CONDUIT, SIGNAL NO. 14 5C	FOOT	1101
ELECTRIC CABLE IN CONDUIT, SIGNAL NO. 14 7C	FOOT	1440
ELECTRIC CABLE IN CONDUIT, LEAD-IN, NO. 14 1 PAIR	FOOT	3308
ELECTRIC CABLE IN CONDUIT, SERVICE, NO. 6 2 C	FOOT	66
ELECTRIC CABLE IN CONDUIT, EQUIPMENT GROUNDING CONDUCTOR, NO. 6 1C	FOOT	1191
TRAFFIC SIGNAL POST, GALVANIZED STEEL 16 FT.	EACH	4
STEEL MAST ARM ASSEMBLY AND POLE, 28 FT.	EACH	2
STEEL MAST ARM ASSEMBLY AND POLE, 38 FT.	EACH	1
STEEL MAST ARM ASSEMBLY AND POLE, 42 FT.	EACH	1
CONCRETE FOUNDATION, TYPE A	FOOT	16
CONCRETE FOUNDATION, TYPE C	FOOT	4
CONCRETE FOUNDATION, TYPE E 30-INCH DIAMETER	FOOT	20
CONCRETE FOUNDATION, TYPE E 36-INCH DIAMETER	FOOT	24
SIGNAL HEAD, L.E.D., 1-FACE, 3 SECTION, MAST ARM MOUNTED	EACH	6
SIGNAL HEAD, L.E.D., 1-FACE, 5 SECTION, BRACKET MOUNTED	EACH	4
SIGNAL HEAD, L.E.D., 1-FACE, 5 SECTION, MAST ARM MOUNTED	EACH	4
PEDESTRIAN SIGNAL HEAD, L.E.D., 1-FACE, BRACKET MOUNTED WITH COUNTDOWN TIMER	EACH	8
TRAFFIC SIGNAL BACK PLATE, LOUVERED, ALUMINUM	EACH	10
INDUCTIVE LOOP DETECTOR	EACH	12
DETECTOR LOOP, TYPE 1	FOOT	1123
LIGHT DETECTOR	EACH	2
LIGHT DETECTOR AMPLIFIER	EACH	1
PEDESTRIAN PUSH-BUTTON	EACH	8
REMOVE EXISTING TRAFFIC SIGNAL EQUIPMENT	EACH	1
REMOVE EXISTING HANDHOLE	EACH	5
REMOVE EXISTING CONCRETE FOUNDATIONS	EACH	10
EMERGENCY VEHICLE PRIORITY SYSTEM LINE SENSOR CABLE, NO. 20 3/C	FOOT	285
FULL-ACTUATED CONTROLLER AND TYPE IV CABINET	EACH	1
TEMPORARY TRAFFIC SIGNAL INSTALLATION	EACH	1
TEMPORARY TRAFFIC SIGNAL TIMING	EACH	1

TYLIN INTERNATIONAL	USER NAME: TUS018	DESIGNED: MBR	REVISED: -	STATE OF ILLINOIS DEPARTMENT OF TRANSPORTATION	INTERSECTION IMPROVEMENT CHURCH STREET AT CRAWFORD AVENUE TRAFFIC SIGNAL IMPROVEMENT PLANS - SHEET 3 OF 3			F.A.U. R.T.E. 1313	SECTION 00-00241-00-CH	COUNTY COOK	TOTAL SHEETS 47	SHEET NO. 23
	PLOT SCALE: 4/SCALE4	DRAWN: -	REVISED: -		SCALE: SHEET NO. OF SHEETS STA. TO STA.			CONTRACT NO. 63734				
	PLOT DATE: 10/17/2013	CHECKED: DBD	REVISED: -		DATE: 10/18/2013			FED. ROAD DIST. NO. [ILLINOIS] FED. AID PROJECT				
		DATE: 10/18/2013	REVISED: -									

P:\N02558\Road\Signal\plan\sk.dgn

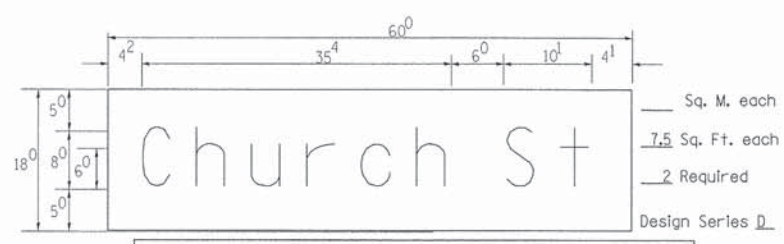
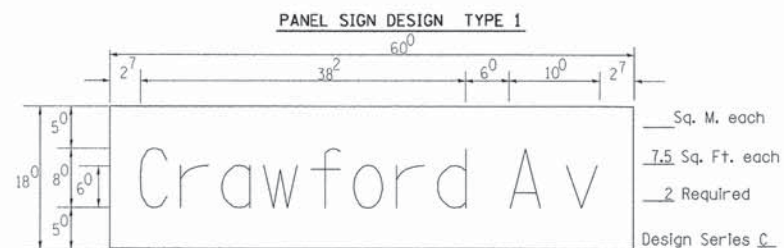

NOTE: SIGN DIMENSIONS ARE IN ENGLISH UNITS

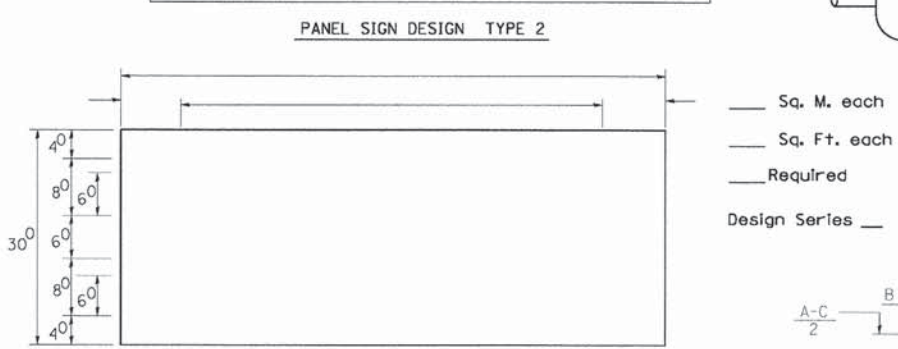

GENERAL NOTES

- WHERE MAST ARM MOUNTED STREET NAME SIGNS ARE SPECIFIED, THE MAST ARM ASSEMBLY AND POLES SHALL BE DESIGNED TO SUPPORT THE LOADINGS CALLED FOR ON STANDARDS 877001, 877002, 877006, 877011 AND 877012, AS APPLICABLE, PLUS TWO (2) SIGN PANELS 2'-6" x 8'-0" MOUNTED AS SHOWN. THE DESIGN SHALL BE IN ACCORDANCE WITH THE REQUIREMENTS OF THE CURRENT "STANDARD SPECIFICATIONS FOR STRUCTURAL SUPPORTS FOR HIGHWAY SIGNS, LUMINAIRES, AND TRAFFIC SIGNALS" AS PUBLISHED BY THE AMERICAN ASSOCIATION OF STATE HIGHWAY AND TRANSPORTATION OFFICIALS FOR 80 M.P.H. WIND VELOCITY.
- ALL SIGNS SHALL HAVE A WHITE REFLECTORIZED LEGEND AND BORDER ON A GREEN REFLECTORIZED BACKGROUND, TYPE A SHEETING.
- THE SIGN LENGTH SHOULD BE INCREASED IN 6-INCH INCREMENTS, BUT THE OVERALL LENGTH SHOULD NOT EXCEED 8'-0".
- ALL BORDERS SHALL BE 3/4" WIDE AND CORNER RADIUS SHALL BE 2-1/4".
- SIGNFIX ALUMINUM CHANNEL FRAMING SYSTEM SHALL BE USED FOR ALL SIGNS ATTACHED TO SIGNAL POLES AND POSTS. LOCAL SUPPLIERS OF THE SIGNFIX ALUMINUM CHANNEL FRAMING SYSTEM ARE:
* J.O. HERBERT CO. MIDLOTHIAN, VA. * WESTERN REMAC INC. WOODRIDGE, IL.

PARTS LISTING:
SIGN CHANNEL PART *HPN053 (MED. CHANNEL)
SIGN SCREWS 1/4" x 14 x 1" H.W.H. #3
BRACKETS PART *HPN034 (UNIVERSAL)
CHANNEL CLAMPS WITH STAINLESS STEEL STRAPPING
OTHER BRANDS OF MOUNTING HARDWARE ARE ACCEPTABLE, BASED UPON THE DEPARTMENT'S APPROVAL AND COMPATIBILITY WITH THE CHANNEL/BACKET OF THE ABOVE PRODUCT.

SUPPORTING CHANNELS

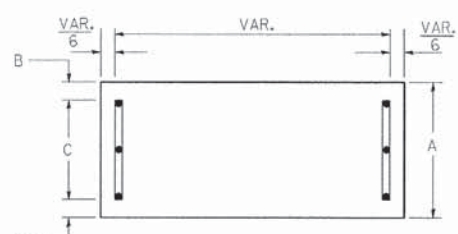

A	B	C
18"	2"	14"

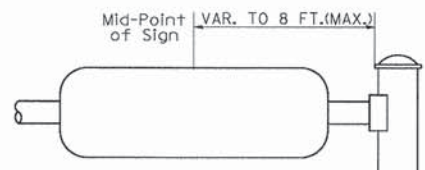

SUPPORTING CHANNELS

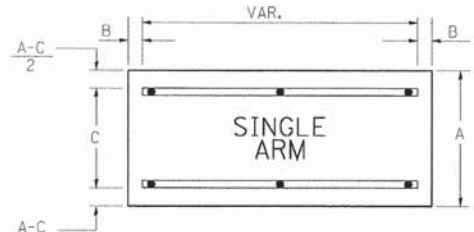

A	B	C
18"	2"	12"
30"	2"	22"

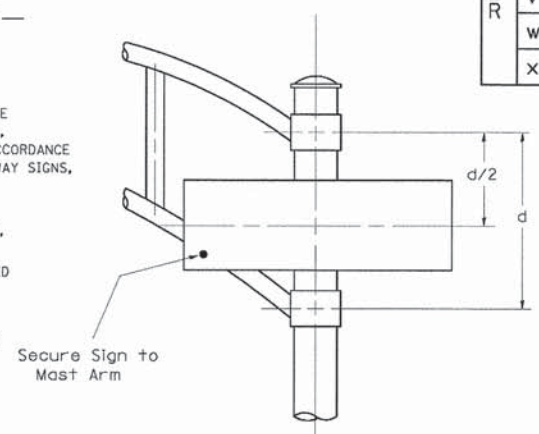

DUAL ARM

SIGNFIX ALUMINUM CHANNEL FRAMING SYSTEM shall be used. See Note #5.

Upper Case To Lower Case
Spacing Chart 8-6 Inch Series "C & D"

SERIES	SECOND LETTER															
	a c c e		b h i k l		f w		j		s t		v y		x		z	
	g o q	m n p r u														
A W X	12	14	14	15	12	14	06	10	11	14	06	10	11	12	12	14
B	14	15	20	21	14	15	11	12	14	15	12	14	12	14	16	17
C E G	14	15	20	21	12	14	06	10	12	14	12	14	14	15	14	15
D O Q R	14	15	20	21	14	15	06	10	12	14	12	14	14	15	14	15
F	05	06	14	15	06	10	05	06	06	10	06	10	06	10	11	12
H I M N	20	21	22	24	20	21	14	15	16	17	16	17	20	21	20	21
J U	20	21	20	21	16	17	14	15	16	17	16	17	16	17	20	21
K L	11	12	16	17	11	12	05	06	11	12	11	12	11	12	12	14
P	12	14	14	15	12	14	05	06	11	12	11	12	12	14	12	14
S	12	14	16	17	12	14	06	10	12	14	12	14	12	14	12	14
T	11	12	16	17	06	10	06	10	11	12	11	12	11	12	12	14
V	06	10	14	15	11	12	06	10	12	14	12	14	12	14	12	14
Y	05	06	14	15	06	10	05	06	05	07	05	06	06	10	11	12
Z	16	17	22	24	16	17	12	14	16	17	16	17	16	17	20	21

Lower Case To Lower Case
Spacing Chart 6 Inch Series "C & D"

SERIES	SECOND LETTER															
	a c c e		b h i k l		f w		j		s t		v y		x		z	
	g o q	m n p r u														
ad h g i j	16	17	22	24	16	17	12	14	14	15	14	15	16	17	16	17
l m n q u																
b f k o p s	12	14	16	17	11	12	05	06	11	12	11	12	12	14	12	14
c e	12	14	16	17	12	14	06	10	12	14	12	14	12	14	12	14
r	06	10	12	14	06	10	03	03	05	06	05	06	06	10	06	10
t z	12	14	16	17	12	14	06	10	11	12	11	12	12	14	12	14
v y	11	12	14	15	11	12	05	06	06	10	06	10	11	12	11	12
w	11	12	14	15	11	12	05	06	11	12	11	12	11	12	12	14
x	12	14	16	17	11	12	05	06	11	12	11	12	11	12	12	14

Number To Number
Spacing Chart 8 Inch Series "C & D"

SERIES	SECOND NUMBER																			
	0		1		2		3		4		5		6		7		8		9	
0 9	16	17	16	17	14	15	12	14	14	15	14	15	16	17	12	14	16	17	16	17
1	20	21	20	21	20	21	16	17	14	15	20	21	20	21	14	15	20	21	20	21
2 3 4	14	15	14	15	14	15	12	14	12	14	14	15	14	15	11	12	16	17	14	15
5	14	15	14	15	14	15	11	12	11	12	14	15	14	15	11	12	14	15	14	15
6	16	17	14	15	14	15	12	15	12	14	14	15	14	15	11	12	14	15	14	15
7	12	14	12	14	14	15	12	15	05	06	12	14	14	15	11	12	14	15	12	14
8	16	17	16	17	14	15	12	15	12	14	14	15	16	17	12	14	16	17	14	15

EXAMPLE, 2³ DENOTES 3/8

UPPER AND LOWER CASE
LETTER WIDTHS

LETTERS	6 INCH UPPER CASE LETTERS		8 INCH UPPER CASE LETTERS		LETTERS	6 INCH LOWER CASE LETTERS	
	SERIES		SERIES			SERIES	
	C	D	C	D		C	D
A	3 ⁶	5 ⁰	5 ⁰	6 ⁵	a	3 ⁵	4 ²
B	3 ²	4 ⁰	4 ³	5 ³	b	3 ⁵	4 ²
C	3 ²	4 ⁰	4 ³	5 ³	c	3 ⁵	4 ¹
D	3 ²	4 ⁰	4 ³	5 ³	d	3 ⁵	4 ²
E	3 ⁰	3 ⁵	4 ⁰	4 ⁷	e	3 ⁵	4 ²
F	3 ⁰	3 ⁵	4 ⁰	4 ⁷	f	2 ³	2 ⁶
G	3 ²	4 ⁰	4 ³	5 ³	g	3 ⁵	4 ²
H	3 ²	4 ⁰	4 ³	5 ³	h	3 ⁵	4 ²
I	0 ⁷	0 ⁷	1 ¹	1 ²	i	1 ¹	1 ¹
J	3 ⁰	3 ⁶	4 ⁰	5 ⁰	j	2 ⁰	2 ²
K	3 ²	4 ¹	4 ³	5 ⁴	k	3 ⁵	4 ²
L	3 ⁰	3 ⁵	4 ⁰	4 ⁷	l	1 ¹	1 ¹
M	3 ⁷	4 ⁵	5 ¹	6 ¹	m	6 ⁰	7 ⁰
N	3 ²	4 ⁰	4 ³	5 ³	n	3 ⁵	4 ²
O	3 ⁴	4 ²	4 ⁵	5 ⁵	o	3 ⁶	4 ³
P	3 ²	4 ⁰	4 ³	5 ³	p	3 ⁵	4 ²
Q	3 ⁴	4 ²	4 ⁵	5 ⁵	q	3 ⁵	4 ²
R	3 ²	4 ⁰	4 ³	5 ³	r	2 ⁶	3 ²
S	3 ²	4 ⁰	4 ³	5 ³	s	3 ⁶	4 ²
T	3 ⁰	3 ⁵	4 ⁰	4 ⁷	t	2 ⁷	3 ²
U	3 ²	4 ⁰	4 ³	5 ³	u	3 ⁵	4 ²
V	3 ⁵	4 ⁴	4 ⁷	6 ⁰	v	4 ²	4 ⁷
W	4 ⁴	5 ²	6 ⁰	7 ⁰	w	5 ⁵	6 ⁴
X	3 ⁴	4 ⁰	4 ⁵	5 ³	x	4 ⁴	5 ¹
Y	3 ⁶	5 ⁰	5 ⁰	6 ⁶	y	4 ⁶	5 ³
Z	3 ²	4 ⁰	4 ³	5 ³	z	3 ⁶	4 ³

NUMBER	6 INCH SERIES		8 INCH SERIES	
	C	D	C	D
1	12	14	15	20
2	3 ²	4 ⁰	4 ³	5 ³
3	3 ²	4 ⁰	4 ³	5 ³
4	3 ⁵	4 ³	4 ⁷	5 ⁷
5	3 ²	4 ⁰	4 ³	5 ³
6	3 ²	4 ⁰	4 ³	5 ³
7	3 ²	4 ⁰	4 ³	5 ³
8	3 ²	4 ⁰	4 ³	5 ³
9	3 ²	4 ⁰	4 ³	5 ³
0	3 ⁴	4 ²	4 ⁵	5 ⁵

FILE NAME =	USER NAME = boward	DESIGNED - DAG/BCK	REVISED - DAG 10/28/09
en\pwork\PW1001\BAUERL\08188315\ts02.dgn		DRAWN - BCK	REVISED -
PLOT SCALE = 49.9999 1/1 IN.		CHECKED - DAG/DAD	REVISED -
PLOT DATE = 11/4/2009		DATE - 03-15-09	REVISED -

STATE OF ILLINOIS
DEPARTMENT OF TRANSPORTATION

DISTRICT ONE
MAST ARM MOUNTED STREET NAME SIGNS

F.A.U. RTE. 1313	SECTION 00-00241-00-CH	COUNTY COOK	TOTAL SHEETS 47	SHEET NO. 24
TS-02			CONTRACT NO. 63734	
FED. ROAD DIST. NO. 1 ILLINOIS FED. AID PROJECT				

SCALE: NONE SHEET NO. 1 OF 1 SHEETS STA. TO STA.

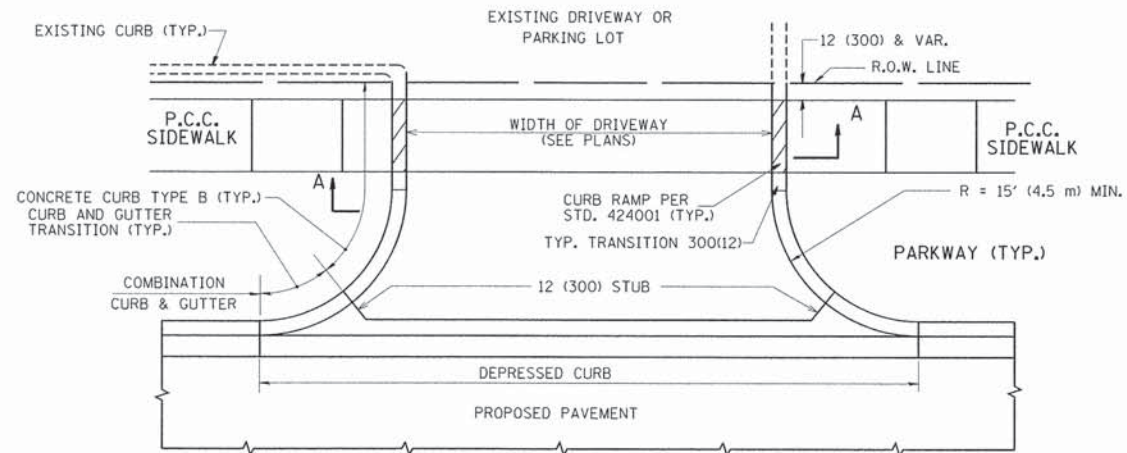

WITH CONCRETE CURB, TYPE B

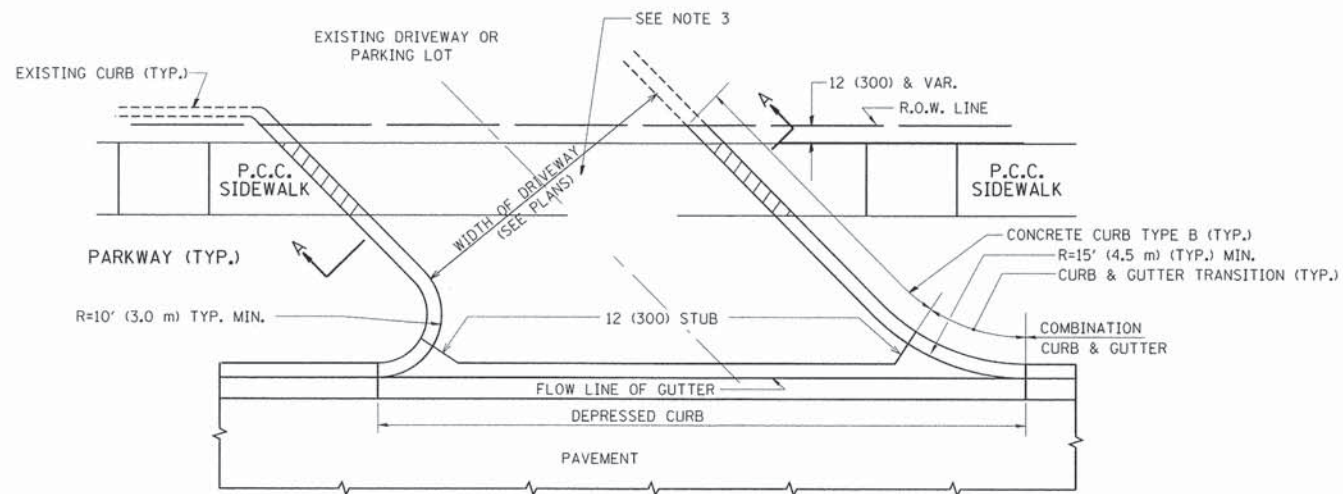

WITH CONCRETE CURB, TYPE B

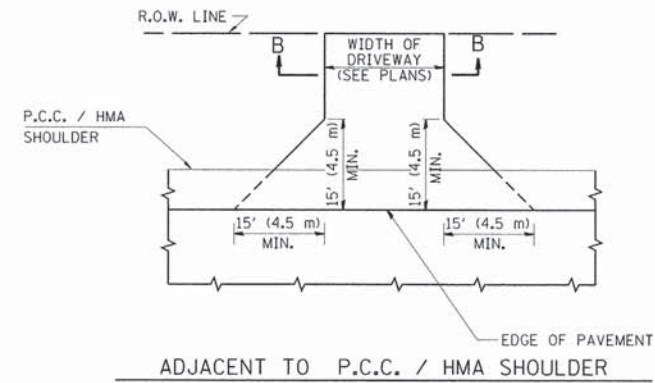
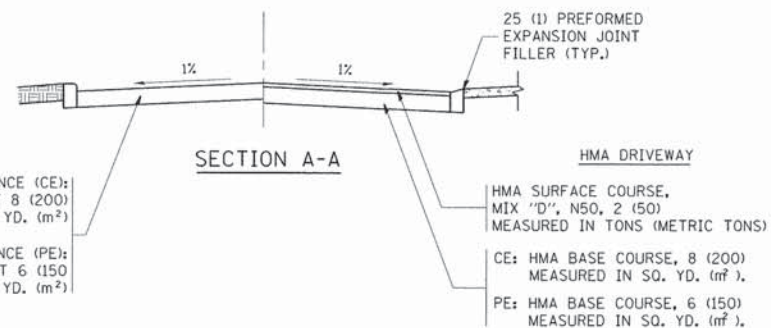

ADJACENT TO P.C.C. / HMA SHOULDER

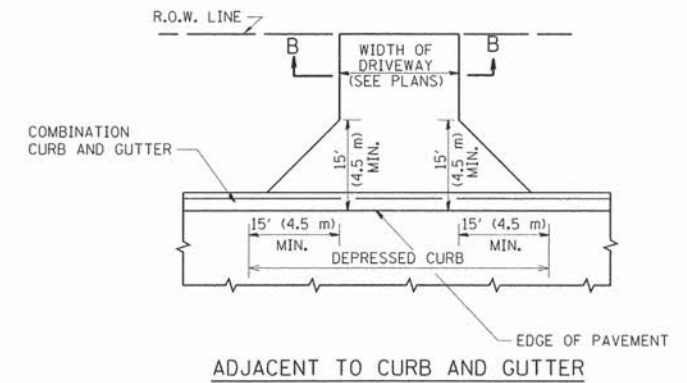

ADJACENT TO CURB AND GUTTER

GENERAL NOTES:

DRIVEWAY SLOPES, LOCATIONS, & GEOMETRIC LAYOUT SHALL BE IN ACCORDANCE WITH THE LATEST EDITION OF THE "HANDBOOK FOR POLICY ON PERMITS FOR ACCESS DRIVEWAYS TO STATE HIGHWAYS". FOR FURTHER LAYOUT REQUIREMENTS, REFER TO ILLUSTRATIONS IN THE PERMIT HANDBOOK. DRIVEWAYS SHALL BE REPLACED IN KIND, UNLESS OTHERWISE NOTED ON THE PLANS.

COMMERCIAL DRIVEWAYS SHALL BE CONSTRUCTED WITH CONCRETE CURB, TYPE B RETURNS EXCEPT WHEN THE SIDEWALK EDGE IS 4 FEET (1.2 METERS) OR LESS FROM THE BACK OF CURB, CONSTRUCT A FLARE DRIVEWAY WITHOUT CURB.

THE RESIDENT ENGINEER SHALL CONTACT THE TRAFFIC PERMIT OFFICE AT 847/ 705-4131 FOR ANY QUESTIONS ON DRIVEWAYS SHOWN IN THE PLANS; SPECIFICALLY IN REFERENCE TO ADDITIONAL AND/OR RELOCATION/REMOVAL OF A DRIVEWAY.

COMBINATION CONCRETE CURB & GUTTER SHALL BE MEASURED STRAIGHT ACROSS THE DRIVEWAY. NO ADDITIONAL COMPENSATION WILL BE ALLOWED FOR THE CURB & GUTTER TRANSITION.

1 (25) PREFORMED EXPANSION JOINT FILLER WILL NOT BE PAID SEPARATELY, BUT SHALL BE CONSIDERED INCLUDED IN THE COST OF THE P.C.C. DRIVEWAY PAVEMENT OR P.C.C. SIDEWALK.

WHEN THE P.C.C. SIDEWALK EXTENDS THROUGH THE DRIVEWAY, THE THICKNESS OF THE SIDEWALK IN THE DRIVEWAY AREA SHALL BE THE SAME AS THE DRIVEWAY THICKNESS. SIDEWALK WILL BE PAID FOR AS P.C.C. SIDEWALK OF THE THICKNESS SPECIFIED. SIDEWALK CROSS SLOPE THRU DRIVEWAY AREA TO BE A MAXIMUM OF 1:50.

FILE NAME =	USER NAME = lryso	DESIGNED - R. SHAH	REVISED - P. LqFLUER 04-15-03
es:\pwork\pwsdot\lryso\d0108315\bd01.dgn		DRAWN -	REVISED - R. BORO 01-01-07
		CHECKED -	REVISED - R. BORO 06-11-08
		DATE - 11-04-95	REVISED - R. BORO 09-06-11

**STATE OF ILLINOIS
DEPARTMENT OF TRANSPORTATION**

**DRIVEWAY DETAILS - DISTANCE BETWEEN R.O.W.
AND FACE OF CURB & EDGE OF SHOULDER >= 15' (4.5 m)**

F.A.U. RTE. 1313	SECTION 00-00241-00-CH	COUNTY COOK	TOTAL SHEETS 47	SHEET NO. 25
BD0156-07 (BD-01)		CONTRACT NO. 63734		
FED. ROAD DIST. NO. 1 ILLINOIS FED. AID PROJECT				

SCALE: NONE SHEET NO. 1 OF 1 SHEETS STA. TO STA.

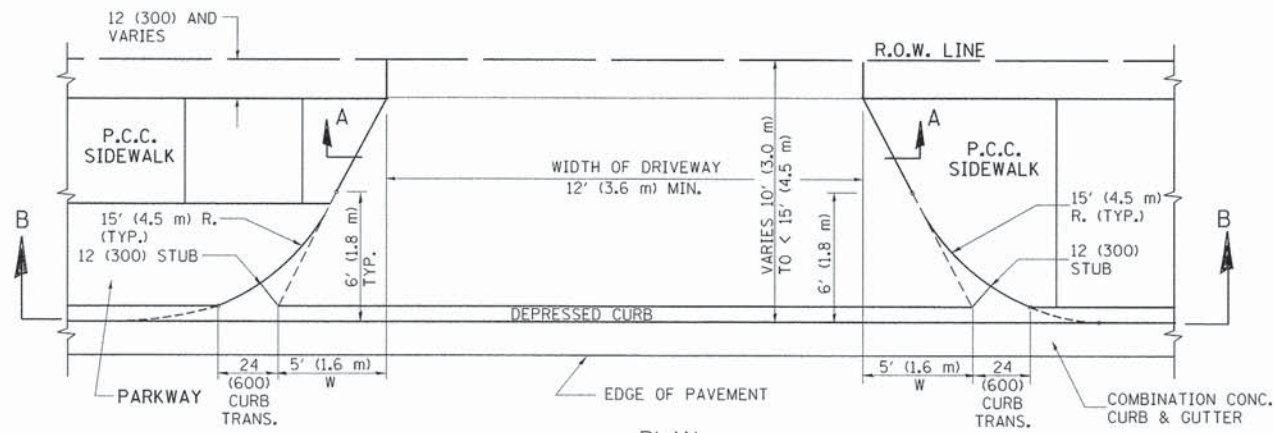

PLAN
10' (3.0 m) TO < 15' (4.5 m)

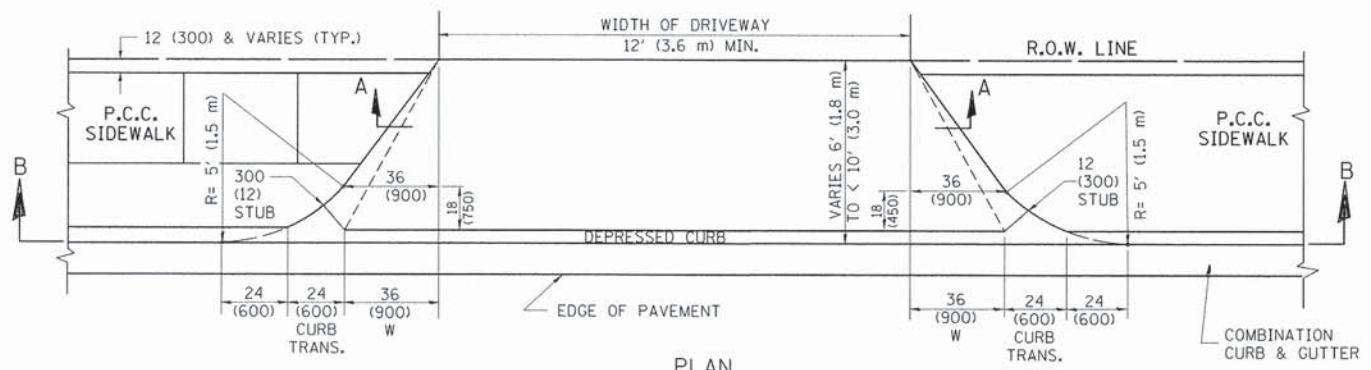

PLAN
6' (1.8 m) TO < 10' (3.0 m)

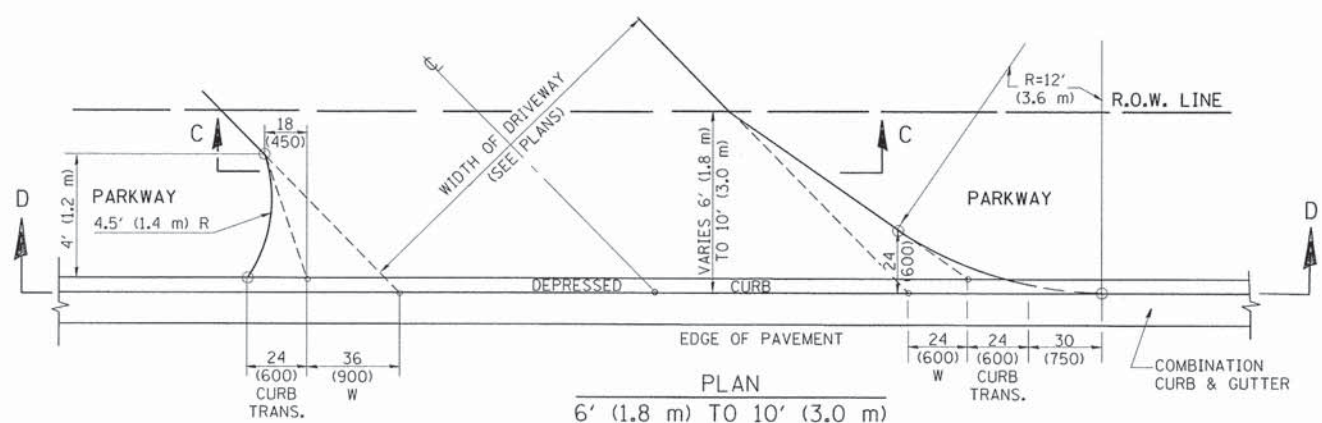

PLAN
6' (1.8 m) TO 10' (3.0 m)

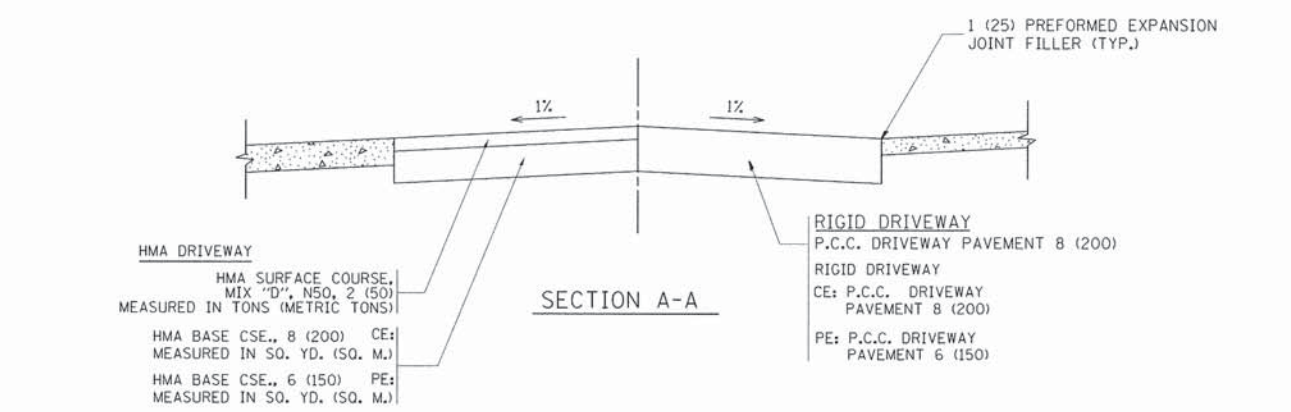

HMA DRIVEWAY
HMA SURFACE COURSE, MIX "D", N50, 2 (50) MEASURED IN TONS (METRIC TONS)
HMA BASE CSE., 8 (200) CE: MEASURED IN SQ. YD. (SQ. M.)
HMA BASE CSE., 6 (150) PE: MEASURED IN SQ. YD. (SQ. M.)

RIGID DRIVEWAY
P.C.C. DRIVEWAY PAVEMENT 8 (200)
RIGID DRIVEWAY
CE: P.C.C. DRIVEWAY PAVEMENT 8 (200)
PE: P.C.C. DRIVEWAY PAVEMENT 6 (150)

SECTION A-A

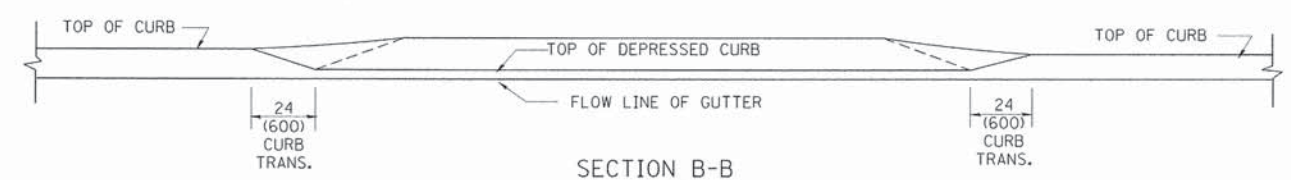

RIGID DRIVEWAY
CE: P.C.C. DRIVEWAY PAVEMENT 8 (200)
PE: P.C.C. DRIVEWAY PAVEMENT 6 (150)

HMA DRIVEWAY
HMA SURFACE COURSE, MIX "D", N50, 2 (50) MEASURED IN TONS (METRIC TONS)
CE: HMA BASE CSE., 8 (200) MEASURED IN SQ. YD. (SQ. M.)
PE: HMA BASE CSE., 6 (150) MEASURED IN SQ. YD. (SQ. M.)

SECTION C-C

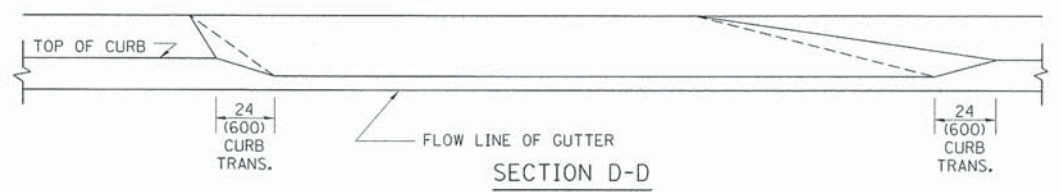

RIGID DRIVEWAY
CE: P.C.C. DRIVEWAY PAVEMENT 8 (200)
PE: P.C.C. DRIVEWAY PAVEMENT 6 (150)

HMA DRIVEWAY
HMA SURFACE COURSE, MIX "D", N50, 2 (50) MEASURED IN TONS (METRIC TONS)
CE: HMA BASE CSE., 8 (200) MEASURED IN SQ. YD. (SQ. M.)
PE: HMA BASE CSE., 6 (150) MEASURED IN SQ. YD. (SQ. M.)

SECTION D-D

GENERAL NOTES

DRIVEWAY SLOPES, LOCATIONS, & GEOMETRIC LAYOUT SHALL BE IN ACCORDANCE WITH THE LATEST EDITION OF THE "HANDBOOK FOR POLICY ON PERMITS FOR ACCESS DRIVEWAYS TO STATE HIGHWAYS". FOR FURTHER LAYOUT REQUIREMENTS, REFER TO ILLUSTRATION 10 IN THE PERMIT HANDBOOK. WHERE SIDEWALKS EXIST, DRIVEWAYS SHALL BE REPLACED WITH RIGID PAVEMENT. WHERE NO SIDEWALKS EXIST, DRIVEWAYS SHALL BE REPLACED IN KIND. SIDEWALK CROSS SLOPE THRU DRIVEWAY AREA TO BE A MAXIMUM OF 1:50.

WHEN THE DISTANCE BETWEEN R.O.W. AND THE BACK OF CURB IS EQUAL TO OR LESS THAN 8' (2.4 m), THE P.C.C. SIDEWALK SHALL EXTEND TO THE BACK OF CURB.

THE RESIDENT ENGINEER SHALL CONTACT THE TRAFFIC PERMIT OFFICE AT 847/ 705-4131 FOR ANY QUESTIONS ON DRIVEWAYS SHOWN IN THE PLANS; SPECIFICALLY IN REFERENCE TO ADDITIONAL AND/OR RELOCATION/REMOVAL OF A DRIVEWAY.

COMBINATION CONCRETE CURB & GUTTER SHALL BE MEASURED STRAIGHT ACROSS THE DRIVEWAY. NO ADDITIONAL COMPENSATION WILL BE ALLOWED FOR THE CURB & GUTTER TRANSITION.

THE 1 (25) PREFORMED EXPANSION JOINT FILLER WILL NOT BE PAID SEPARATELY, BUT SHALL BE CONSIDERED INCLUDED IN THE COST OF THE P.C.C. DRIVEWAY PAVEMENT OR P.C.C. SIDEWALK.

"W" VARIES FROM 36 (900) TO 5' (1.5 m) PROPORTIONAL TO THE LENGTH (L), FROM 6' (1.8 m) TO 10' (3 m).

ALL DIMENSIONS ARE IN INCHES (MILLIMETERS) UNLESS OTHERWISE NOTED.

FILE NAME =	USER NAME = lsgn	DESIGNED - R. SHAH	REVISED - M. GOMEZ 04-06-01
ct:\pwork\pwork\lsgn\ad0189315\bd02.dgn		DRAWN -	REVISED - P. LoFLEUR 04-15-03
		CHECKED -	REVISED - R. BORO 01-01-07
		DATE - 11-06-95	REVISED - R. BORO 09-06-11

STATE OF ILLINOIS
DEPARTMENT OF TRANSPORTATION

DRIVEWAY DETAILS	
DISTANCE BETWEEN ROW AND FACE OF CURB < 15' (4.5 m)	
SCALE: NONE	SHEET NO. 1 OF 1 SHEETS STA. TO STA.

F.A.U. RTE.	SECTION	COUNTY	TOTAL SHEETS	SHEET NO.
1313	00-00241-00-CH	COOK	47	26
BD400-02 (BD-02)			CONTRACT NO. 63734	
FED. ROAD DIST. NO. 1 ILLINOIS FED. AID PROJECT				

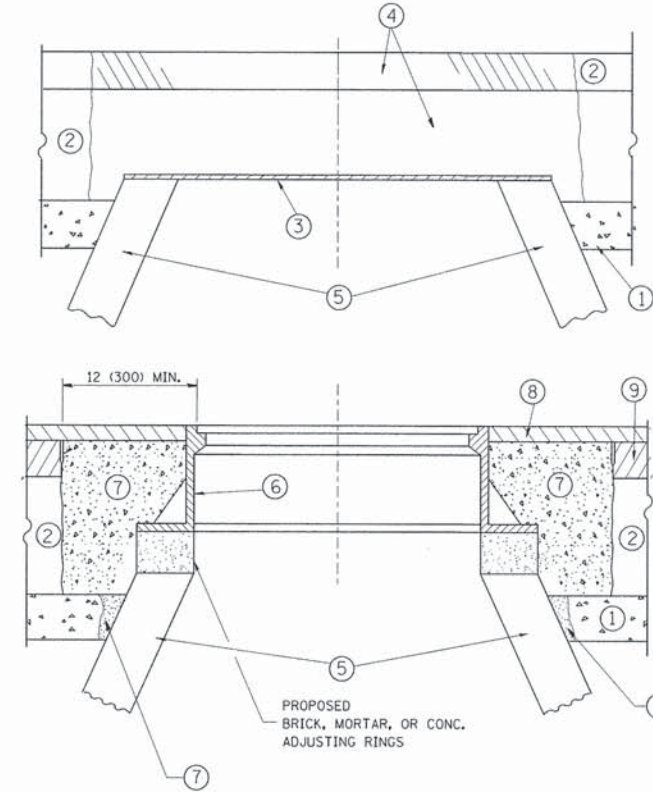

CONSTRUCTION PROCEDURES

STAGE 1 (BEFORE PAVEMENT MILLING)

- A) REMOVE A MINIMUM OF 12 (300) OF THE PAVEMENT FROM AROUND THE STRUCTURE.
- B) REMOVE THE EXISTING FRAME AND LID FROM THE STRUCTURE.
- C) COVER THE STRUCTURE OPENING WITH A 36 (900) DIAMETER METAL PLATE.
- D) BACKFILL WITH CRUSHED STONE AND A MINIMUM 1 1/2 (40) THICK HMA SURFACE MIX APPROVED BY THE ENGINEER.

STAGE 2 (AFTER PAVEMENT MILLING)

- A) REMOVE THE HMA SURFACE MIX AND CRUSHED STONE.
- B) INSTALL THE FRAME AND LID; ADJUST THE FRAME TO ITS FINAL SURFACE ELEVATION.
- C) THE SURROUNDING SPACE SHALL BE FILLED WITH CLASS PP-1* CONCRETE TO THE ELEVATION OF THE SURFACE OF THE EXISTING BASE COURSE OR THE BINDER COURSE.

* UNLESS OTHERWISE SPECIFIED IN THE PLANS.

THE PROCEDURE EXPLAINED ABOVE SHALL CONFORM TO THE APPLICABLE PORTIONS OF SECTIONS 353, 406, 602, AND 603 OF THE STANDARD SPECIFICATIONS EXCEPT THAT "THE CONTRACTOR SHALL ADJUST THE STRUCTURES TO THE FINISHED PAVEMENT ELEVATION NO MORE THAN 5 CALENDAR DAYS PRIOR TO PLACEMENT OF THE FINAL LIFT OF SURFACE UNLESS APPROVED BY THE ENGINEER."

LEGEND

- ① SUB-BASE GRANULAR MATERIAL
- ② EXISTING PAVEMENT
- ③ 36 (900) DIAMETER METAL PLATE
- ④ PROPOSED CRUSHED STONE AND HMA SURFACE MIX
- ⑤ EXISTING STRUCTURE
- ⑥ FRAME AND LID (SEE NOTES)
- ⑦ CLASS PP-1* CONCRETE
- ⑧ PROPOSED HMA SURFACE COURSE
- ⑨ PROPOSED HMA BINDER COURSE

LOCATION OF STRUCTURES:

THE CONTRACTOR WILL BE REQUIRED TO KEEP A RECORD OF THE LOCATIONS OF THE BURIED STRUCTURES ACCORDING TO THE STATION AND DISTANCE LEFT OR RIGHT OF THE CENTERLINE OF PAVEMENT. UPON COMPLETION OF THE WORK, THE CONTRACTOR WILL DELIVER THE RECORD TO THE ENGINEER.

BASIS OF PAYMENT:

REMOVING FRAMES AND LIDS ON DRAINAGE AND UTILITY STRUCTURES IN THE PAVEMENT PRIOR TO MILLING, AND ADJUSTING TO FINAL GRADE PRIOR TO PLACING THE SURFACE COURSE, WILL BE PAID FOR AT THE CONTRACT UNIT PRICE EACH FOR "FRAMES AND LIDS TO BE ADJUSTED (SPECIAL)."

THIS WORK WILL NOT BE PAID FOR WHEN DRAINAGE AND UTILITY STRUCTURES ARE SPECIFIED FOR PAYMENT AS STRUCTURE RECONSTRUCTION.

NEW FRAMES AND LIDS, WHEN SPECIFIED, WILL BE PAID FOR SEPARATELY.

NOTES:

EXISTING BROKEN FRAMES AND LIDS SHALL BE REMOVED AND DISPOSED OF BY THE CONTRACTOR AND SHALL BE REPLACED AS DIRECTED BY THE ENGINEER. REPLACEMENT FRAMES AND LIDS WILL BE PAID FOR IN ACCORDANCE WITH ARTICLE 109.04 OF THE STANDARD SPECIFICATIONS UNLESS A SEPARATE PAY ITEM HAS BEEN PROVIDED.

IF THE EXISTING LIDS ARE OPEN, THE FRAME WILL BE ADJUSTED TO THE ELEVATION OF THE MILLED PAVEMENT SURFACE PRIOR TO THE MILLING OPERATION. THE FRAME WILL NOT BE REMOVED AND COVERED BY THE METAL PLATE.

CITY OF CHICAGO CASTINGS ARE THE PROPERTY OF THE CITY AND THE CONTRACTOR SHALL NOTIFY THE CITY FOR REMOVAL AND DISPOSITION OF THE CASTINGS.

THE METAL PLATE USED TO COVER THE STRUCTURE SHALL REMAIN THE PROPERTY OF THE CONTRACTOR.

WHEN STRUCTURES ARE TO BE ADJUSTED OR RECONSTRUCTED, THE LOWERING AND RAISING OF THE FRAMES AND LIDS WILL NOT BE PAID FOR SEPARATELY BUT WILL BE INCLUDED IN THE COST OF THE CORRESPONDING PAY ITEM.

DETAILS FOR FRAMES AND LIDS ADJUSTMENT WITH MILLING

ALL DIMENSIONS ARE IN INCHES (MILLIMETERS) UNLESS OTHERWISE SHOWN

FILE NAME : c:\pwwork\pwwork\bauserdl\d0108315\bd08.dgn	USER NAME : bauserdl	DESIGNED : R. SHAH	REVISED : R. WIEDEMAN 05-14-04
		DRAWN : -	REVISED : R. BORO 01-01-07
		CHECKED : -	REVISED : R. BORO 03-09-11
		DATE : 10-25-94	REVISED : R. BORO 12-06-11

**STATE OF ILLINOIS
DEPARTMENT OF TRANSPORTATION**

DETAILS FOR FRAMES AND LIDS ADJUSTMENT WITH MILLING			
SCALE: NONE	SHEET NO. 1 OF 1 SHEETS	STA.	TO STA.

F.A.U. RTE. 1313	SECTION 00-00241-00-CH	COUNTY COOK	TOTAL SHEETS 47	SHEET NO. 27
BD600-03 (BD-8)			CONTRACT NO. 63734	
FED. ROAD DIST. NO. 1 (ILLINOIS) FED. AID PROJECT				

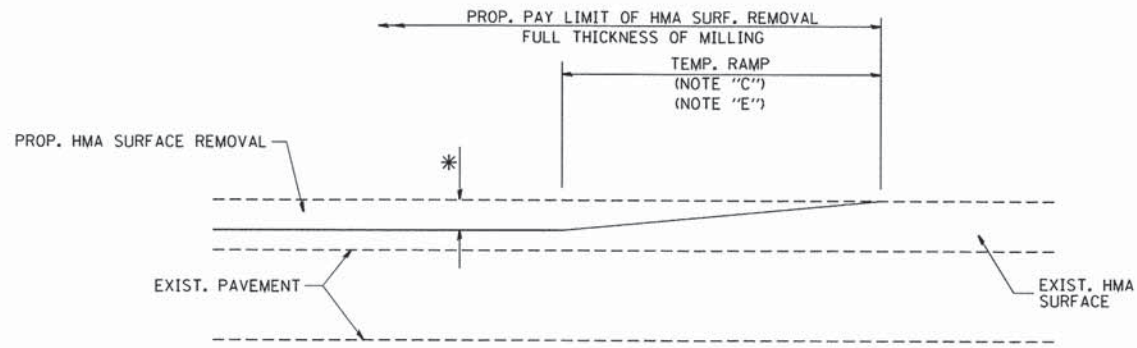

MILLED TEMPORARY RAMP
(FOR BUTT JOINT AND HMA TAPER SEE DETAIL BELOW)

OPTION 1

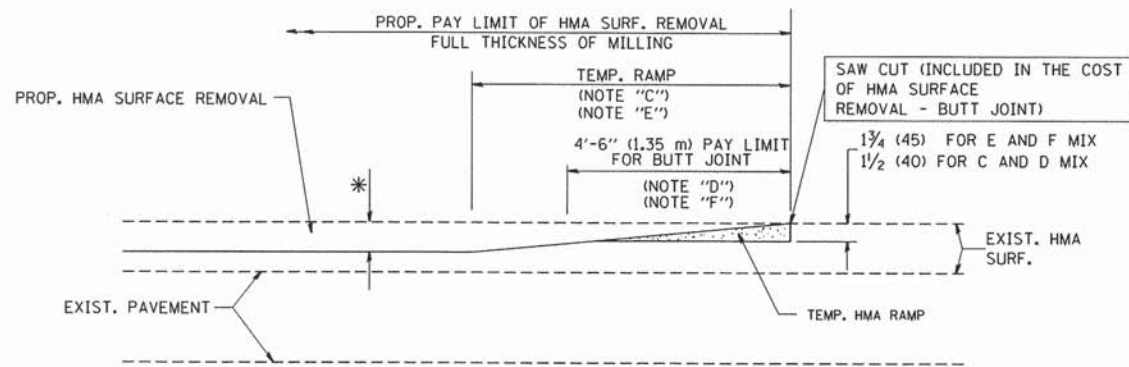

HMA CONSTRUCTED TEMPORARY RAMP
(FOR BUTT JOINT AND HMA TAPER SEE DETAIL BELOW)

OPTION 2
TYPICAL TEMPORARY RAMP

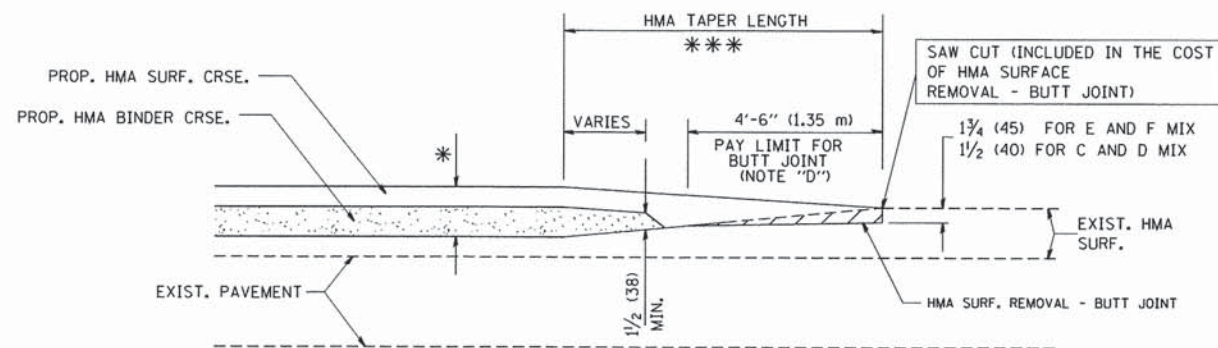

BUTT JOINT AND HMA TAPER
TYPICAL BUTT JOINT AND HMA TAPER FOR MILLING AND RESURFACING

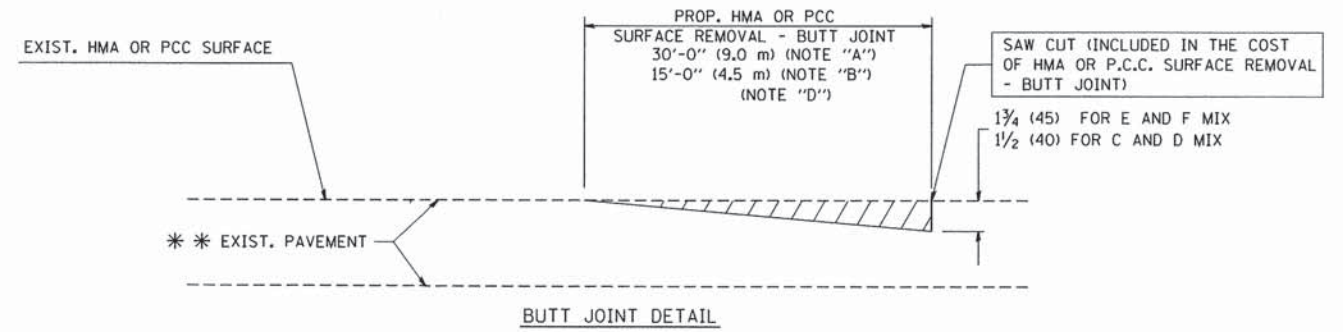

BUTT JOINT DETAIL

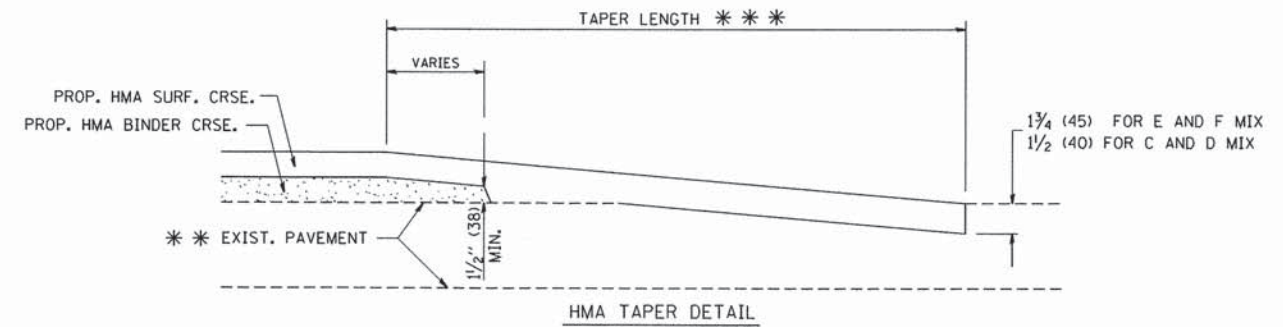

TYPICAL BUTT JOINT AND HMA TAPER FOR RESURFACING ONLY

*** PC CONCRETE, HMA OR HMA RESURFACED PAVEMENT.

NOTES

- A: MAINLINE ROADWAYS AND MAJOR SIDE ROADS.
- B: MINOR SIDE ROADS.
- C: THE TEMP. RAMP SHALL BE CONSTRUCTED IMMEDIATELY UPON REMOVAL OF THE EXISTING HMA SURFACE.
- D: THE BUTT JOINT SHALL BE CONSTRUCTED IMMEDIATELY PRIOR TO PLACING THE PROPOSED HMA COURSES.
- E: TAPER THE TEMP. RAMP AT A RATE OF 3'-0" (900 mm) PER 1 INCH (25 mm) OF MILLING THICKNESS.
- F: INSTALLATION AND REMOVAL OF THE 4'-6" (1.35 m) TEMP. RAMP IS INCLUDED IN COST OF HMA SURFACE REMOVAL - BUTT JOINT
- G: SEE ARTICLE 406.08 AND 406.14 OF THE STANDARD SPECIFICATIONS FOR "HMA AND/OR PCC SURFACE REMOVAL, BUTT JOINT".
- * SEE TYPICAL SECTIONS FOR MILLING THICKNESS.
- *** 20'-0" (6.1 m) PER 1 (25) RESURFACING (NOTE "A")
10'-0" (3.0 m) PER 1 (25) RESURFACING (NOTE "B")

BASIS OF PAYMENT:

THE BUTT JOINT WILL BE PAID FOR AT THE CONTRACT UNIT PRICE PER SQUARE YARD (SQUARE METER) FOR "HOT-MIX ASPHALT SURFACE REMOVAL - BUTT JOINT" OR FOR "PORTLAND CEMENT CONCRETE SURFACE REMOVAL - BUTT JOINT".

ALL DIMENSIONS ARE IN INCHES (MILLIMETERS) UNLESS OTHERWISE SHOWN.

FILE NAME = W:\diststd\22x34\bd32.dgn	USER NAME = geglienobt	DESIGNED - M. DE YONG	REVISED - R. SHAH 10-25-94
		DRAWN -	REVISED - A. ABBAS 03-21-97
	PLOT SCALE = 50.0000' / IN.	CHECKED -	REVISED - M. GOMEZ 04-06-01
	PLOT DATE = 1/4/2008	DATE - 06-13-90	REVISED - R. BORO 01-01-07

**STATE OF ILLINOIS
DEPARTMENT OF TRANSPORTATION**

**BUTT JOINT AND
HMA TAPER DETAILS**

SCALE: NONE SHEET NO. 1 OF 1 SHEETS STA. TO STA.

F.A.U. RTE. 1313	SECTION 00-00241-00-CH	COUNTY COOK	TOTAL SHEETS 47	SHEET NO. 28
BD400-05 BD32			CONTRACT NO. 63734	
FED. ROAD DIST. NO. 1 [ILLINOIS] FED. AID PROJECT				

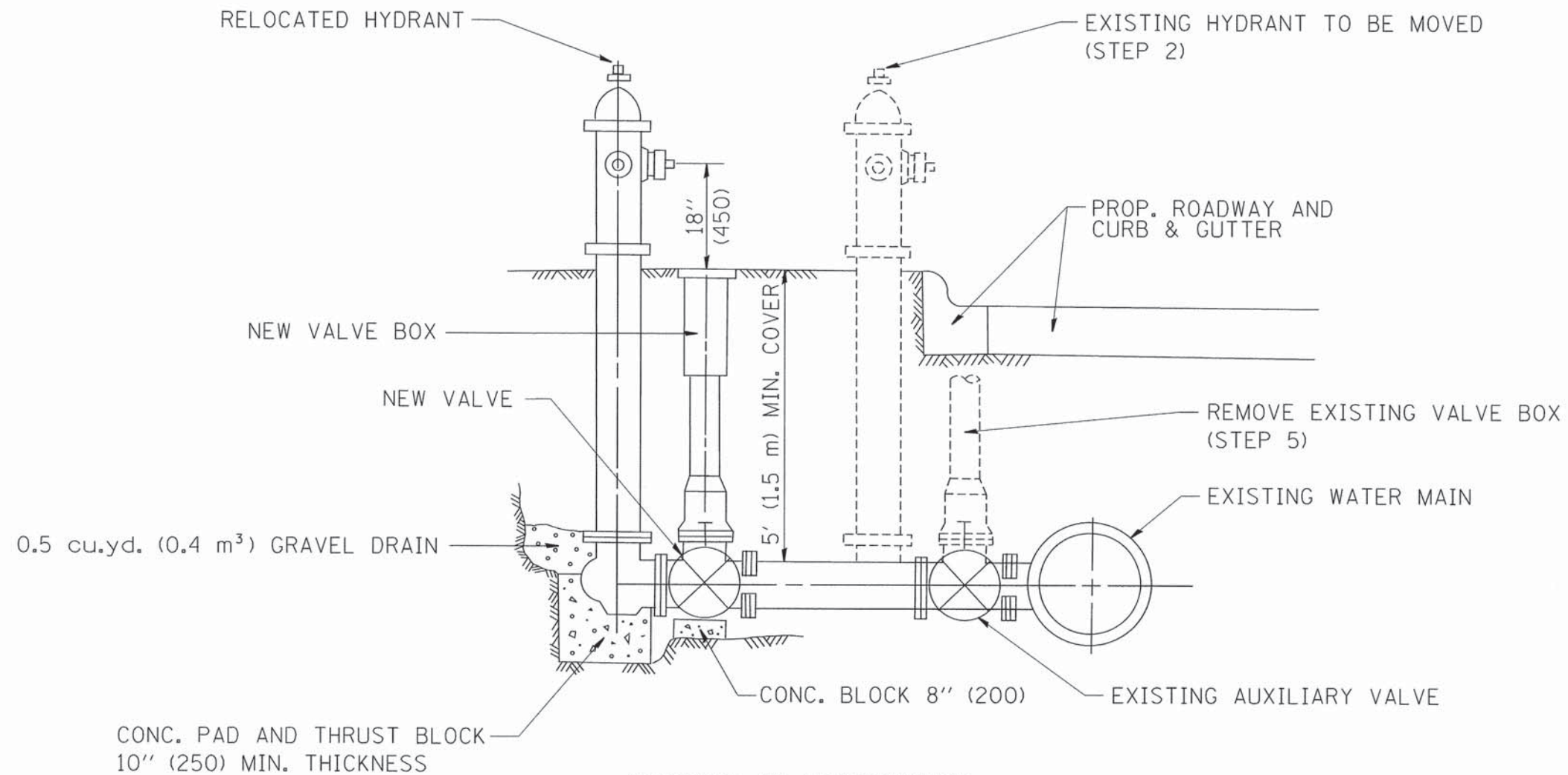

SEQUENCE OF CONSTRUCTION:

1. CLOSE EXISTING VALVE.
2. REMOVE EXISTING HYDRANT.
3. INSTALL HYDRANT EXTENSION AND NEW VALVE.
4. RELOCATE EXISTING HYDRANT.
5. OPEN EXISTING VALVE, REMOVE BOX.
6. BACKFILL.
7. FLUSH AND TEST FOR CHLORIDE RESIDUAL AND PROVIDE TEST.

ALL WORK TO BE DONE IN ACCORDANCE WITH ARTICLE 564 OF THE STANDARD SPECIFICATIONS. NEW VALVE AND BOX SHALL BE SAME MAKE AND MODEL AS EXISTING.

FIRE HYDRANT TO BE MOVED

ALL DIMENSIONS ARE IN INCHES (MILLIMETERS) UNLESS OTHERWISE SHOWN.

FILE NAME = W:\diststd\22x34\bd36.dgn	USER NAME = geglionbt	DESIGNED -	REVISED - R. SHAH 09-09-94	STATE OF ILLINOIS DEPARTMENT OF TRANSPORTATION	FIRE HYDRANT TO BE MOVED			F.A.U. RTE.	SECTION	COUNTY	TOTAL SHEETS	SHEET NO.
	PLOT SCALE = 50,0000 ' / IN.	DRAWN -	REVISED - R. SHAH 10-25-94					1313	00-00241-00-CH	COOK	47	29
PLOT DATE = 1/4/2000	DATE -	REVISED -	REVISED -	SCALE: NONE	SHEET NO. 1 OF 1 SHEETS	STA.	TO STA.	BD-36		CONTRACT NO. 63734		
								FED. ROAD DIST. NO. 1 ILLINOIS FED. AID PROJECT				

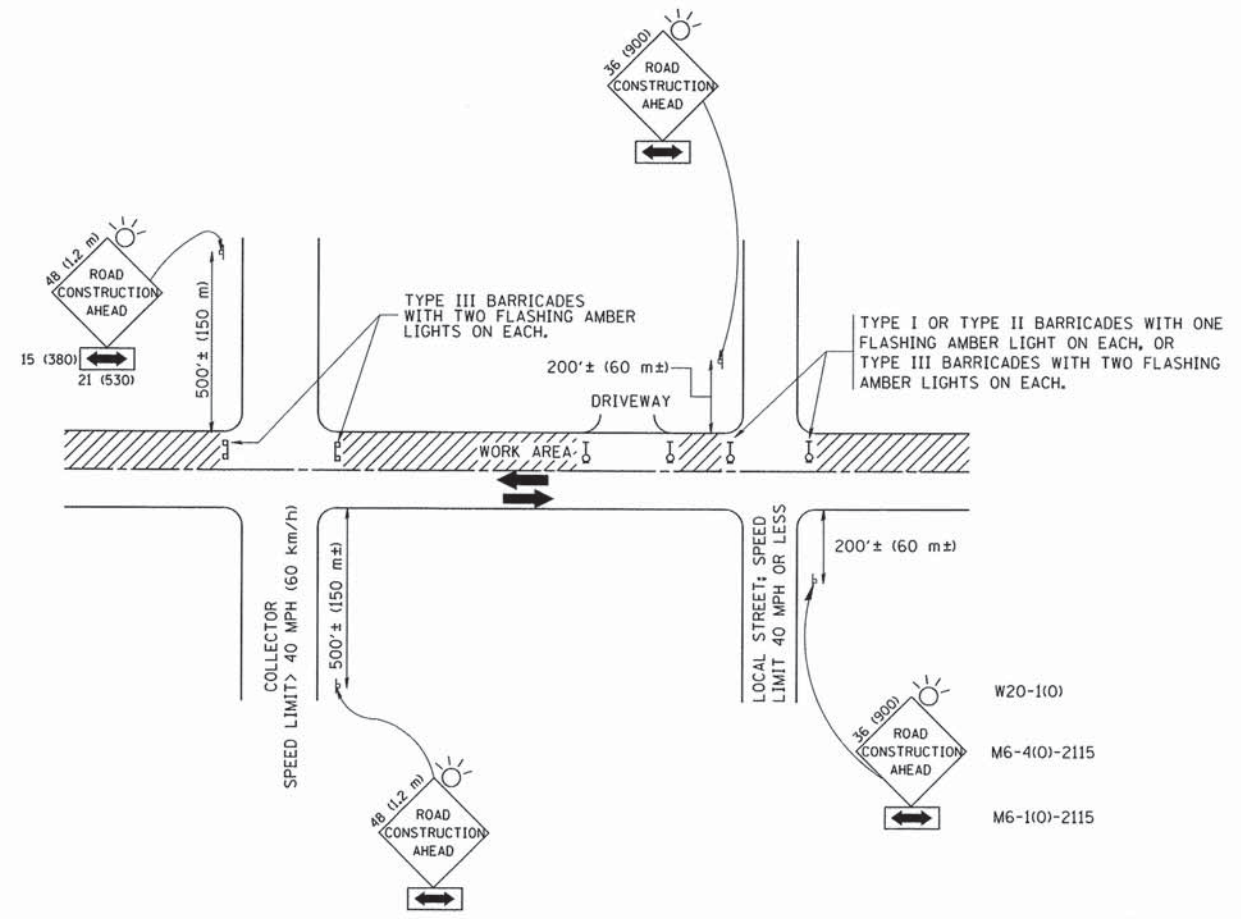

TRAFFIC CONTROL AND PROTECTION FOR SIDE ROADS, INTERSECTIONS, AND DRIVEWAYS

NOTES:

- A. FOR NO LANE RESTRICTION ON THE SIDE ROAD OR DRIVEWAYS
 1. SIDE ROAD WITH A SPEED LIMIT OF 40 MPH (60 km/h) OR LESS AS SHOWN ON THE DRAWING AND AS DIRECTED BY THE ENGINEER:
 - a) ONE ROAD CONSTRUCTION AHEAD SIGN 36 x 36 (900x900) WITH A FLASHER AND FLAG MOUNTED ON IT APPROXIMATELY 200' (60 m) IN ADVANCE OF THE MAIN ROUTE.
 - b) THE CLOSED PORTION OF THE MAIN ROUTE SHALL BE PROTECTED BY BLOCKING WITH TYPE I, TYPE II OR TYPE III BARRICADES, 1/3 OF THE CROSS SECTION OF THE CLOSED PORTION.
 2. SIDE ROAD WITH A SPEED LIMIT GREATER THAN 40 MPH (60 km/h) AS SHOWN ON THE DRAWING AND AS DIRECTED BY THE ENGINEER:
 - a) ONE ROAD CONSTRUCTION AHEAD SIGN 48 x 48 (1.2 m x 1.2 m) WITH A FLASHER MOUNTED ON IT APPROXIMATELY 500' (150 m) IN ADVANCE OF THE MAIN ROUTE.
 - b) THE CLOSED PORTION OF THE MAIN ROUTE SHALL BE PROTECTED BY BLOCKING WITH TYPE III BARRICADES, 1/2 OF THE CROSS SECTION OF THE CLOSED PORTION.
- 3. WHEN THE SIDE ROAD LIES BETWEEN THE BEGINNING OF THE MAINLINE SIGNING AND THE WORK ZONE, A SINGLE HEADED ARROW (M6-1) SHALL BE USED IN LIEU OF THE DOUBLE HEADED ARROW (M6-4).
- B. FOR A LANE CLOSURE ON A SIDE ROAD OR DRIVEWAY:

USE APPLICABLE PORTIONS OF THE TYPICAL APPLICATION OF TRAFFIC CONTROL DEVICES (STD. 701501, STD. 701606 OR THE APPROPRIATE STANDARD). THE SPACING OF SIGNS AND BARRICADES SHALL BE ADJUSTED FOR FIELD CONDITIONS AS DIRECTED BY THE ENGINEER. THE DIRECTIONAL ARROW SHALL BE COVERED OR REMOVED WHEN NO LONGER CONSISTENT WITH THE SIDE ROAD LANE CLOSURE.
- C. ADVANCE WARNING SIGNS ARE TO BE OMITTED ON DRIVEWAY UNLESS OTHERWISE NOTED.
- D. THE TRAFFIC CONTROL AND PROTECTION FOR SIDE ROADS, INTERSECTIONS, AND DRIVEWAYS SHALL BE INCIDENTAL TO THE COST OF SPECIFIED TRAFFIC CONTROL STANDARDS OR ITEMS.

All dimensions are in millimeters (Inches) unless otherwise shown.

FILE NAME = W:\diststd\22x34\tcl0.dgn	USER NAME = goglionobt	DESIGNED - LHA	REVISED - J. OBERLE 10-18-95
		DRAWN -	REVISED - A. HOUSEH 03-06-96
	PLOT SCALE = 50,000 ' / IN.	CHECKED -	REVISED - A. HOUSEH 10-15-96
	PLOT DATE = 1/4/2008	DATE - 06-89	REVISED - T. RAMMACHER 01-06-00

STATE OF ILLINOIS
DEPARTMENT OF TRANSPORTATION

TRAFFIC CONTROL AND PROTECTION FOR
SIDE ROADS, INTERSECTIONS, AND DRIVEWAYS

SCALE: NONE SHEET NO. 1 OF 1 SHEETS STA. TO STA.

F.A.U. RTE.	SECTION	COUNTY	TOTAL SHEETS	SHEET NO.
1313	00-00241-00-CH	COOK	47	30
TC-10			CONTRACT NO. 63734	
FED. ROAD DIST. NO. 1 [ILLINOIS] FED. AID PROJECT				

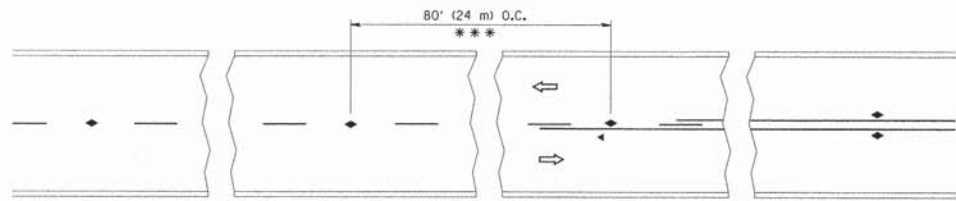

*** REDUCE TO 40' (12 m) O.C. ON CURVES WITH POSTED OR ADVISORY SPEED 45 M.P.H. (70 km/h) OR LESS.

TWO-LANE/TWO-WAY

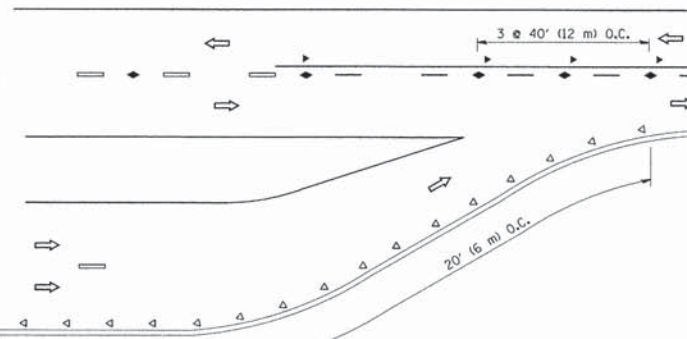

LANE REDUCTION TRANSITION

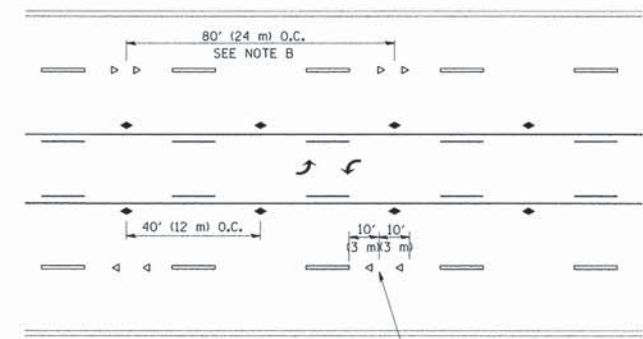

TWO-WAY LEFT TURN

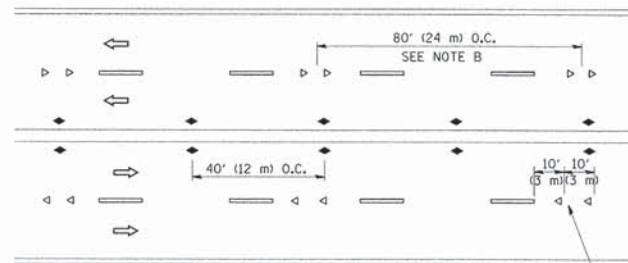

MULTI-LANE/UNDIVIDED

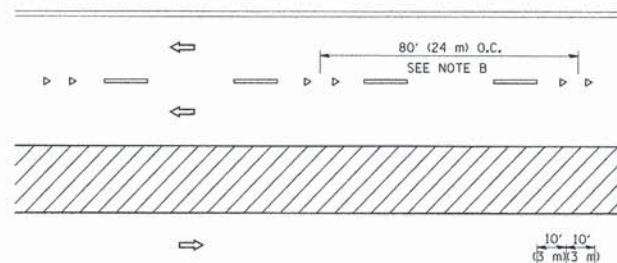

MULTI-LANE/DIVIDED

GENERAL NOTES

1. MARKERS USED WITH DASHED LINES SHALL BE CENTERED IN THE GAP BETWEEN SEGMENTS.
2. MARKERS USED ADJACENT TO SOLID LINES SHALL BE OFFSET 2 TO 3 (50 TO 75) TOWARD TRAFFIC AS SHOWN.
3. MARKERS THROUGH TANGENTS LESS THAN 500' (150 m) IN LENGTH BETWEEN CURVES SHALL BE INSTALLED AT THE LESSER OF THE TWO CURVE SPACINGS.

SYMBOLS

- YELLOW STRIPE
- WHITE STRIPE
- ◀ ONE-WAY AMBER MARKER
- ◄ ONE-WAY CRYSTAL MARKER (W/O)
- ◆ TWO-WAY AMBER MARKER

LANE MARKER NOTES

- A. USE DOUBLE LANE LINE MARKERS SPACED AS SHOWN.
- B. REDUCE TO 40' (12 m) O.C. ON CURVES WHERE ADVISORY SPEEDS ARE 10 M.P.H (20 km/h) LOWER THAN POSTED SPEEDS.

DESIGN NOTES

1. DOUBLE LANE LINE MARKERS SHALL BE USED UNLESS SPECIFIED OTHERWISE.
2. EXCEPT AS SHOWN ON THE LANE REDUCTION TRANSITION AND FREEWAY EXIT RAMP DETAIL, MARKERS ARE NOT TO BE SPECIFIED ON RIGHT EDGE LINES.
3. THE EXACT MARKER LIMITS, SPACING, AND COLOR SHALL BE INCLUDED IN THE PLANS WHEN STANDARD SPECIFICATIONS ARE NOT BEING USED.
4. MARKERS SHOULD NOT BE USED ALONGSIDE CURBS EXCEPT FOR EXTREMELY SHORT SECTIONS OF CURBS WHERE NOT MORE THAN TWO MARKERS WOULD BE INVOLVED.

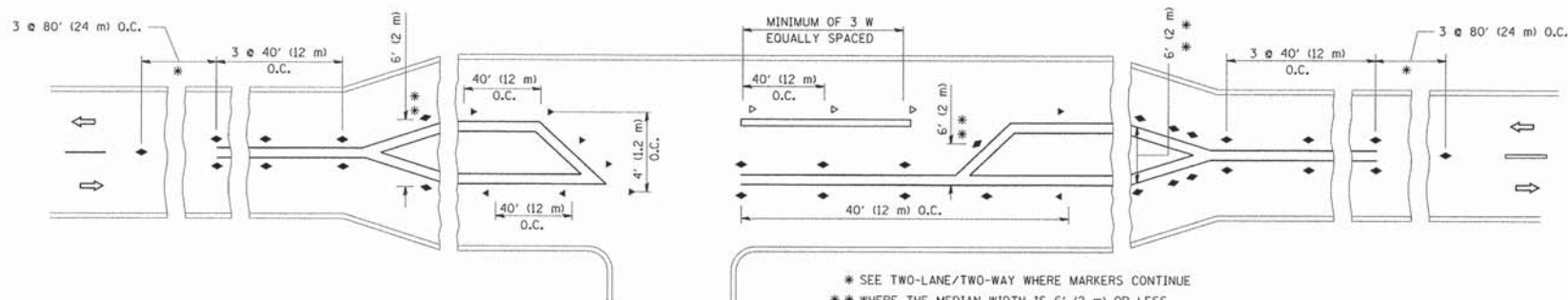

LEFT TURN

* SEE TWO-LANE/TWO-WAY WHERE MARKERS CONTINUE
 ** WHERE THE MEDIAN WIDTH IS 6' (1.2 m) OR LESS USE TWO-WAY MARKERS.

All dimensions are in inches (millimeters) unless otherwise shown.

FILE NAME =	USER NAME = leyso	DESIGNED -	REVISED - T. RAMMACHER 09-19-94
cc:\pvc\work\pwsdot\1\eyso\00188315\11.dgn		DRAWN -	REVISED - T. RAMMACHER 03-12-99
	PLOT SCALE = 50,000 / IN.	CHECKED -	REVISED - T. RAMMACHER 01-06-00
	PLOT DATE = 3/2/2011	DATE -	REVISED - C. JUCIUS 09-09-09

STATE OF ILLINOIS
 DEPARTMENT OF TRANSPORTATION

TYPICAL APPLICATIONS			
RAISED REFLECTIVE PAVEMENT MARKERS (SNOW-PLOW RESISTANT)			
SCALE: NONE	SHEET NO. 1 OF 1 SHEETS	STA.	TO STA.

F.A.U. RTE.	SECTION	COUNTY	TOTAL SHEETS	SHEET NO.
1313	00-00241-00-CH	COOK	47	31
TC-11			CONTRACT NO. 63734	
FED. ROAD DIST. NO. 1 [ILLINOIS] FED. AID PROJECT				

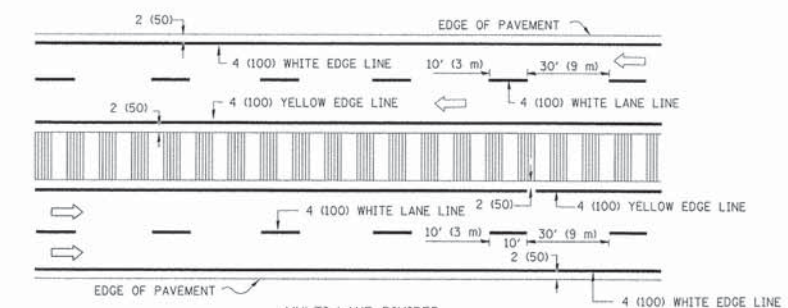
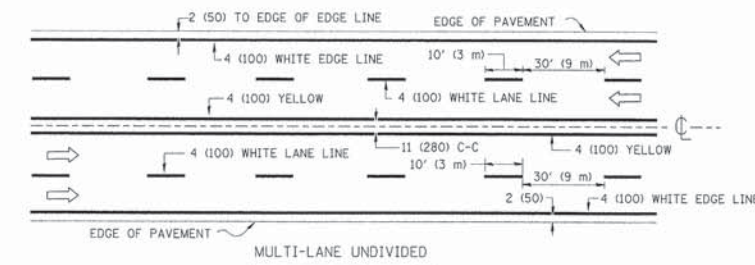
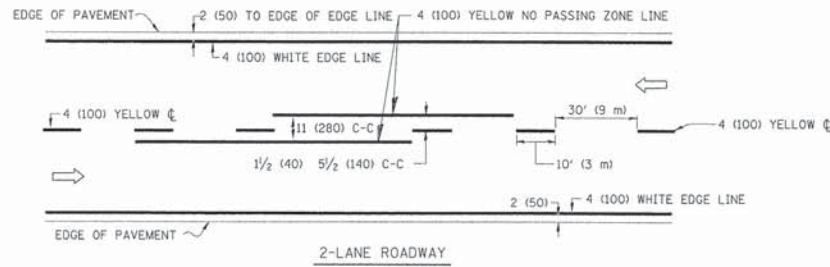

TYPICAL LANE AND EDGE LINE MARKING

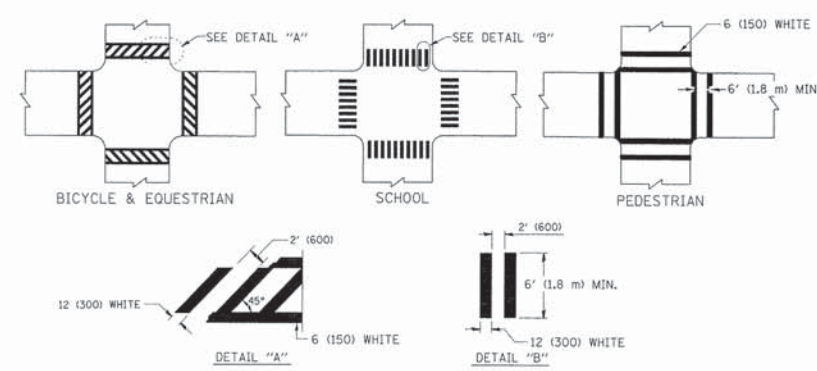

TYPICAL CROSSWALK MARKING

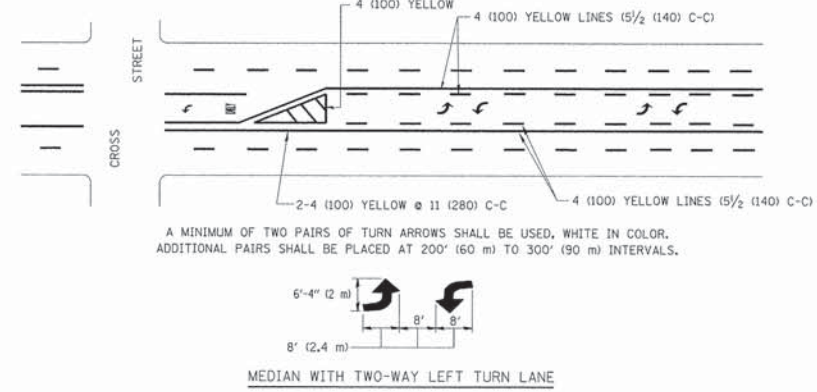
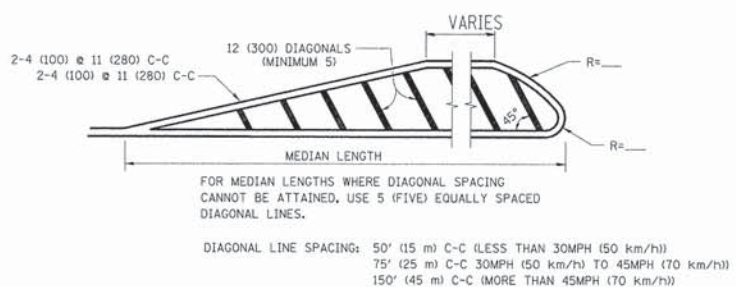
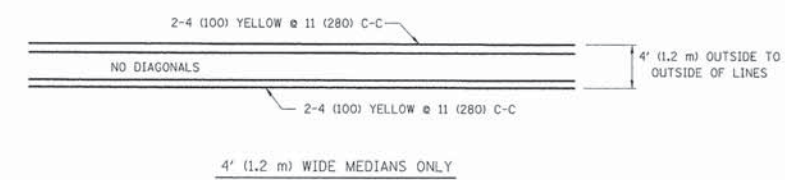

TYPICAL PAINTED MEDIAN MARKING

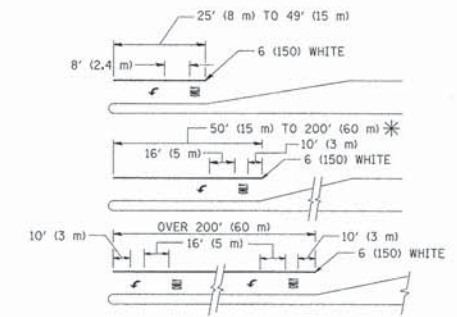

FULL SIZE LETTERS 8" (2.4 m) AND ARROWS SHALL BE USED.
 AREA = 15.6 SQ. FT. (1.5 m²) ONLY AREA = 20.8 SQ. FT. (1.9 m²)
 * TURN LANES IN EXCESS OF 400' (120 m) IN LENGTH MAY HAVE AN ADDITIONAL SET OF ARROW - "ONLY" INSTALLED MIDWAY BETWEEN THE OTHER TWO SETS OF ARROW - "ONLY".

TYPICAL LEFT (OR RIGHT) TURN LANE

TYPICAL TURN LANE MARKING

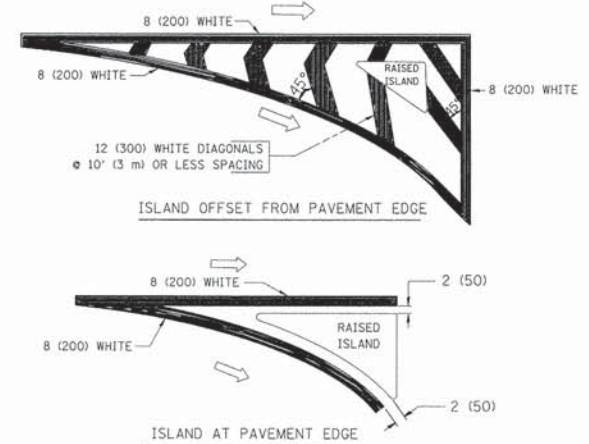

TYPICAL ISLAND MARKING

TYPE OF MARKING	WIDTH OF LINE	PATTERN	COLOR	SPACING / REMARKS
CENTERLINE ON 2 LANE PAVEMENT	4 (100)	SKIP-DASH	YELLOW	10' (3 m) LINE WITH 30' (9 m) SPACE
CENTERLINE ON MULTI-LANE UNDIVIDED PAVEMENT	2 @ 4 (100)	SOLID	YELLOW	11 (280) C-C
NO PASSING ZONE LINES: FOR ONE DIRECTION FOR BOTH DIRECTIONS	4 (100) 2 @ 4 (100)	SOLID SOLID	YELLOW YELLOW	5/2 (140) C-C FROM SKIP-DASH CENTERLINE 11 (280) C-C OMIT SKIP-DASH CENTERLINE BETWEEN
LANE LINES	4 (100) 5 (125) ON FREEWAYS	SKIP-DASH SKIP-DASH	WHITE WHITE	10' (3 m) LINE WITH 30' (9 m) SPACE
DOTTED LINES (EXTENSIONS OF CENTER, LANE OR TURN LANE MARKINGS)	SAME AS LINE BEING EXTENDED	SKIP-DASH	SAME AS LINE BEING EXTENDED	2' (600) LINE WITH 6' (1.8 m) SPACE
EDGE LINES	4 (100)	SOLID	YELLOW-LEFT WHITE-RIGHT	OUTLINE MOUNTABLE MEDIANS IN YELLOW; EDGE LINES ARE NOT USED NEXT TO BARRIER CURB
TURN LANE MARKINGS	6 (150) LINE; FULL SIZE LETTERS & SYMBOLS (8" (2.4m))	SOLID	WHITE	SEE TYPICAL TURN LANE MARKING DETAIL
TWO WAY LEFT TURN MARKING	2 @ 4 (100) EACH DIRECTION 8' (2.4m) LEFT ARROW	SKIP-DASH AND SOLID IN PAIRS	YELLOW WHITE	10' (3 m) LINE WITH 30' (9 m) SPACE FOR SKIP-DASH; 5/2 (140) C-C BETWEEN SOLID LINE AND SKIP-DASH LINE SEE TYPICAL TWO-WAY LEFT TURN MARKING DETAIL
CROSSWALK LINES (PEDESTRIAN) A. DIAGONALS (BIKE & EQUESTRIAN) B. LONGITUDINAL BARS (SCHOOL)	2 @ 6 (150) 12 (300) @ 45° 12 (300) @ 90°	SOLID SOLID SOLID	WHITE WHITE WHITE	NOT LESS THAN 6' (1.8 m) APART 2' (600) APART SEE TYPICAL CROSSWALK MARKING DETAILS.
STOP LINES	24 (600)	SOLID	WHITE	PLACE 4' (1.2 m) IN ADVANCE OF AND PARALLEL TO CROSSWALK, IF PRESENT. OTHERWISE, PLACE AT DESIRED STOPPING POINT. PARALLEL TO CROSSROAD CENTERLINE, WHERE POSSIBLE.
PAINTED MEDIANS	2 @ 4 (100) WITH 12 (300) DIAGONALS @ 45° NO DIAGONALS USED FOR 4' (1.2 m) WIDE MEDIANS	SOLID	YELLOW; TWO WAY TRAFFIC WHITE; ONE WAY TRAFFIC	11 (280) C-C FOR THE DOUBLE LINE SEE TYPICAL PAINTED MEDIAN MARKING.
GORE MARKING AND CHANNELIZING LINES	8 (200) WITH 12 (300) DIAGONALS @ 45°	SOLID	WHITE	DIAGONALS: 15' (4.5 m) C-C (LESS THAN 30MPH (50 km/h)) 20' (6 m) C-C 30MPH (50 km/h) TO 45MPH (70 km/h) 30' (9 m) C-C (OVER 45MPH (70 km/h))
RAILROAD CROSSING	24 (600) TRANSVERSE LINES; "RR" 15 6" (1.8 m) LETTERS; 16 (400) LINE FOR "X"	SOLID	WHITE	SEE STATE STANDARD 780001 AREA OF: "R"=3.6 SQ. FT. (0.33 m ²) EACH "X"=54.0 SQ. FT. (5.0 m ²)
SHOULDER DIAGONALS	12 (300) @ 45°	SOLID	WHITE - RIGHT YELLOW - LEFT	50' (15 m) C-C (LESS THAN 30MPH (50 km/h)) 75' (25 m) C-C 30 MPH (50 km/h) TO 45MPH (70 km/h) 150' (45 m) C-C (OVER 45MPH (70 km/h))

FOR FURTHER DETAILS ON PAVEMENT MARKING REFER TO STANDARD SPECIFICATIONS FOR ROAD AND BRIDGE CONSTRUCTION AND STATE STANDARD 780001.

All dimensions are in inches (millimeters) unless otherwise shown.

FILE NAME =	USER NAME = drvakosgn	DESIGNED - EVERS	REVISED - T. RAMMACHER 10-27-94
ct\pwork\pwsdot\drvakosgn\d0108315\td3.dgn		DRAWN -	REVISED - C. JUCIUS 09-09-09
PLOT SCALE = 50,000' / IN.		CHECKED -	REVISED -
PLOT DATE = 9/9/2009		DATE - 03-19-90	REVISED -

STATE OF ILLINOIS
DEPARTMENT OF TRANSPORTATION

DISTRICT ONE		F.A.U. R.T.E.	SECTION	COUNTY	TOTAL SHEETS	SHEET NO.
TYPICAL PAVEMENT MARKINGS		1313	00-00241-00-CH	COOK	47	32
SCALE: NONE		SHEET NO. 1 OF 1 SHEETS		STA.	TO STA.	

TC-13		CONTRACT NO. 63734	
FED. ROAD DIST. NO. 1 [ILLINOIS] FED. AID PROJECT			

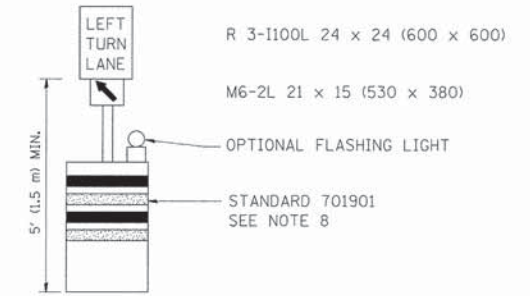
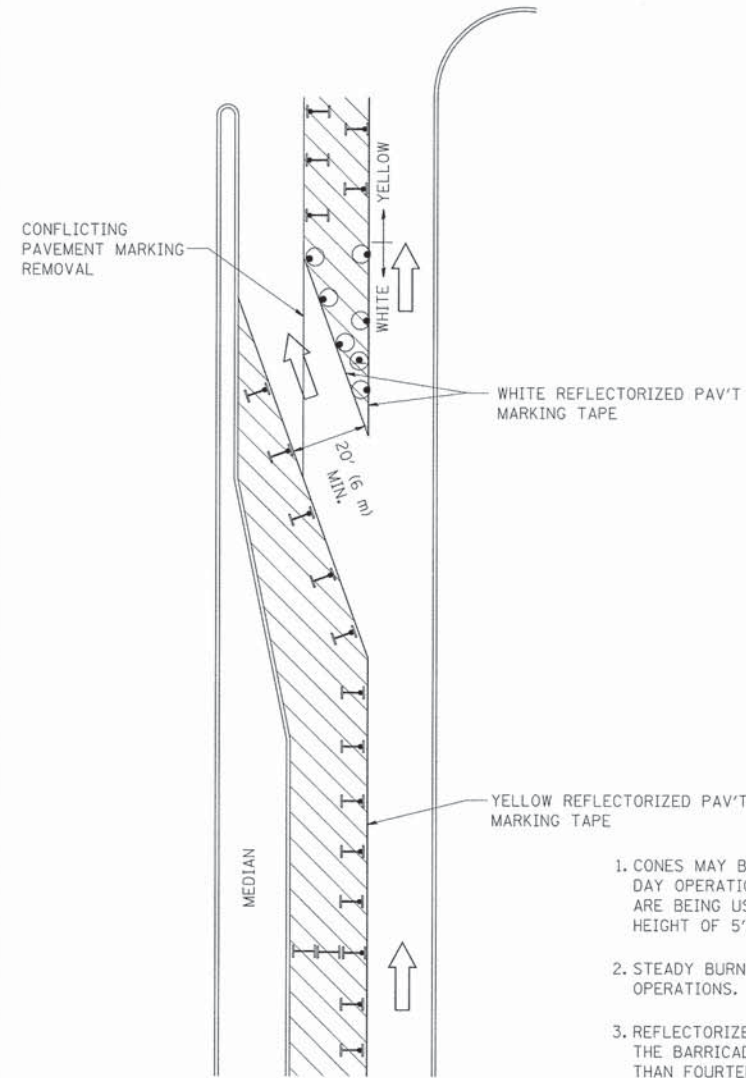







GENERAL NOTES

1. CONES MAY BE SUBSTITUTED FOR BARRICADES OR DRUMS AT HALF THE SPACING DURING DAY OPERATIONS. CONES SHALL BE A MINIMUM OF 28 (710) IN HEIGHT. WHEN CONES ARE BEING USED, THE "LEFT TURN LANE" SIGN MAY BE SKID MOUNTED AT A MINIMUM HEIGHT OF 5' (1.5 m).
2. STEADY BURNING LIGHTS WILL NOT BE REQUIRED ON BARRICADES OR DRUMS FOR DAY OPERATIONS. ALL LIGHTS SHALL BE MONODIRECTIONAL.
3. REFLECTORIZED TEMPORARY PAVEMENT MARKING TAPE SHALL BE PLACED THROUGHOUT THE BARRICADED AREA OF EACH TURN BAY WHERE THE CLOSURE TIME IS GREATER THAN FOURTEEN DAYS.
4. THIS APPLICATION ALSO APPLIES WHEN WORK IS BEING PERFORMED IN THE RIGHT LANE(S) AND THE RIGHT TURN BAY IS TO REMAIN OPEN. UNDER THIS CONDITION, "RIGHT TURN LANE" R3-100 24 x 24 (600 x 600) AND M6-2R 21 x 15 (530 x 380) SHALL BE USED.
5. THESE CONTROLS SHALL SUPPLEMENT MAINLINE TRAFFIC CONTROL FOR LANE CLOSURES.
6. LONGITUDINAL DIMENSIONS MAY BE ADJUSTED TO FIT FIELD CONDITIONS.
7. FORM OPER 725 IS REQUIRED.
8. IF A DRUM OR TYPE II BARRICADE WITH AN ATTACHED SIGN PANEL WHICH MEETS NCHRP 350 REQUIREMENTS IS NOT AVAILABLE, THE SIGNS SHALL BE MOUNTED, ABOVE THE BARRICADES, ON SEPARATE SIGNS SUPPORTS THAT MEET NCHRP 350 PREQUIREMENTS.
9. TRAFFIC CONTROL AND PROTECTION AT TURN BAYS (TO REMAIN OPEN TO TRAFFIC) SHALL BE INCLUDED IN THE COST SPECIFIED TRAFFIC CONTROL STANDARDS OR ITEMS.

All dimensions are in inches (millimeters) unless otherwise shown.

LEGEND

-  WORK AREA
-  LANE OPEN TO TRAFFIC
-  TYPE I OR II BARRICADE WITH STEADY BURN LIGHT
-  DRUM WITH STEADY BURN LIGHT
-  DRUM WITH SIGN (WITH OPTIONAL FLASHING LIGHT) SEE DETAIL
-  TYPE I OR II CHECK BARRICADE WITH FLASHING LIGHT

FILE NAME =	USER NAME = drvakasn	REVISED -T. RAMMACHER 09-08-94	REVISED - R. BORO 09-14-09
ct:\pw\work\PWID01\DRIVAKOSGN\d81863151	14.dgn	REVISED - A. HOUSEH 11-07-95	REVISED -
	PLOT SCALE = 49,9999 ' / IN.	REVISED - A. HOUSEH 10-12-96	REVISED -
	PLOT DATE = 9/14/2009	REVISED -T. RAMMACHER 01-06-00	REVISED -

**STATE OF ILLINOIS
DEPARTMENT OF TRANSPORTATION**

**TRAFFIC CONTROL AND PROTECTION AT TURN BAYS
(TO REMAIN OPEN TO TRAFFIC)**

SCALE: NONE SHEET NO. 1 OF 1 SHEETS STA. TO STA.

F.A.U. RTE.	SECTION	COUNTY	TOTAL SHEETS	SHEET NO.
1313	00-00241-00-CH	COOK	47	33
TC-14		CONTRACT NO. 63734		
<small>FED. ROAD DIST. NO. 1 [ILLINOIS] FED. AID PROJECT</small>				

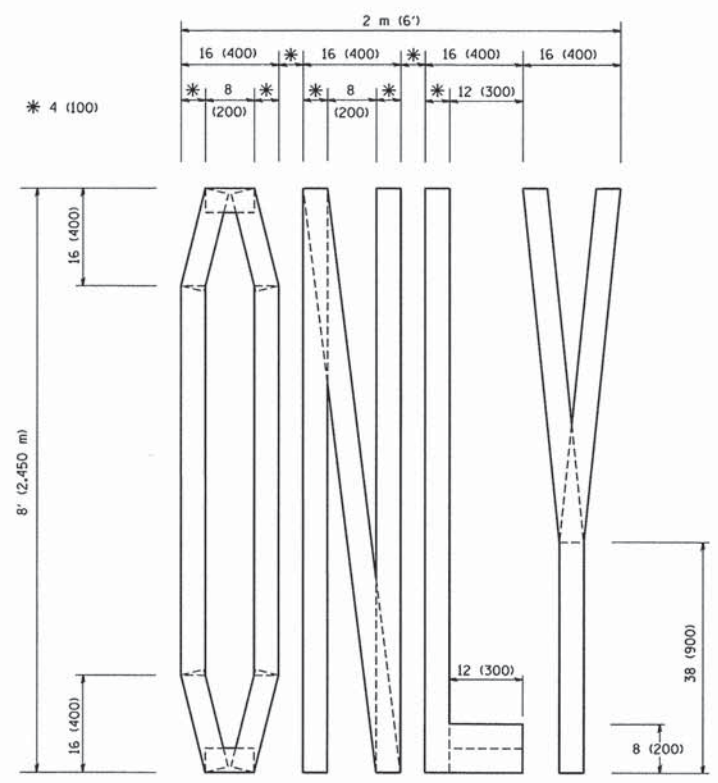

QUANTITY
 4 (100) LINE = 64.1 ft. (19.7 m)
 21.1 sq. ft. (1.97 sq. m)

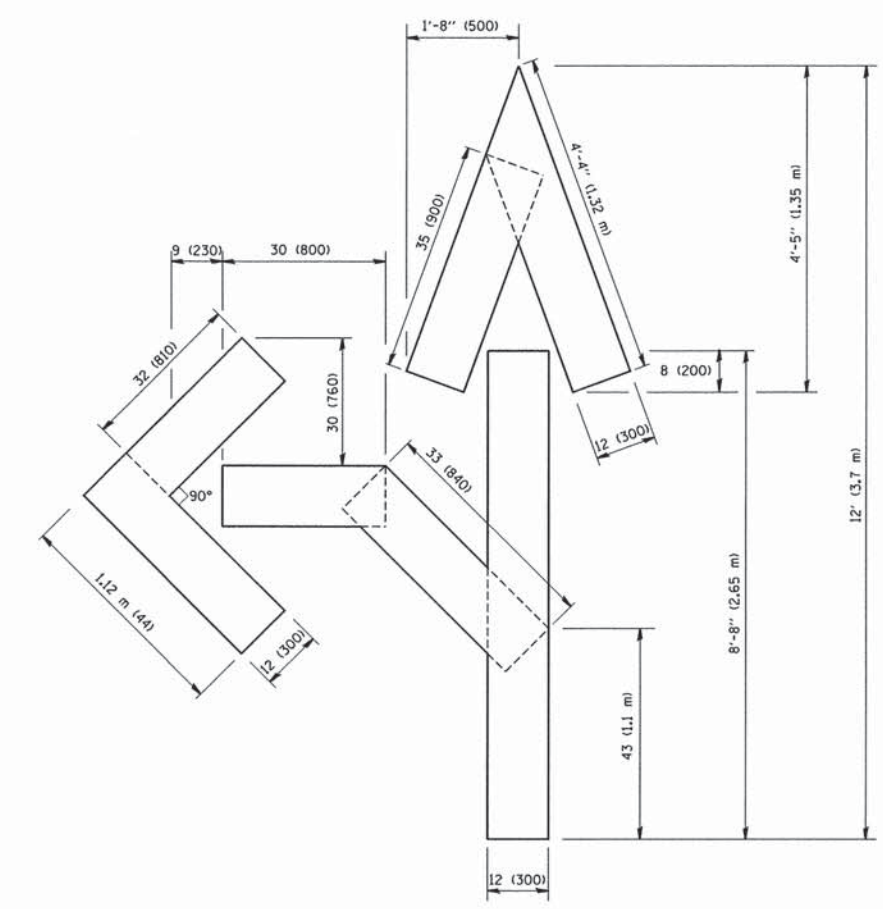

QUANTITY
 4 (100) LINE = 82.5 ft. (25.3 m)
 27.5 sq. ft. (2.53 sq. m)

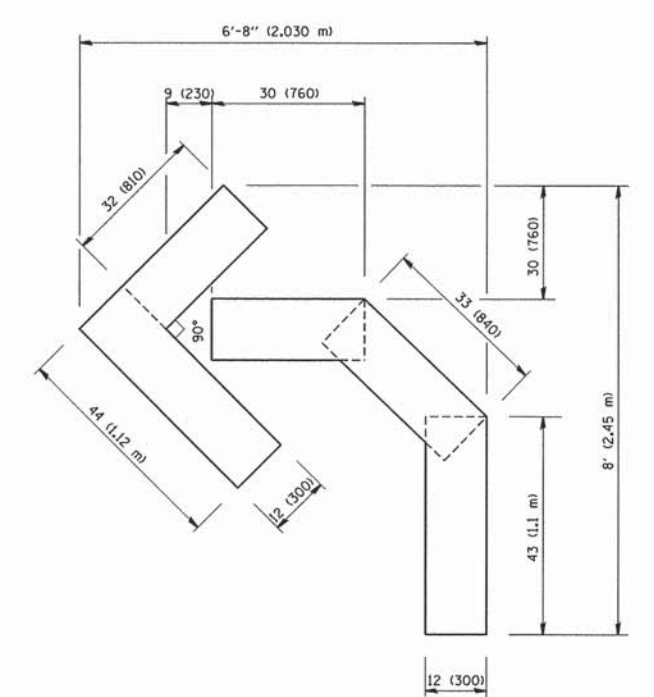

QUANTITY
 4 (100) LINE = 45.5 ft. (13.9 m)
 15.2 sq. ft. (1.39 sq. m)

All dimensions are in inches (millimeters) unless otherwise shown.

FILE NAME = W:\diststd\22x34\tbl6.dgn	USER NAME = geglennob	DESIGNED -	REVISED -T, RAMMACHER 06-05-96
		DRAWN -	REVISED -T, RAMMACHER 11-04-97
	PLOT SCALE = 50,0000 ' / IN.	CHECKED -	REVISED -T, RAMMACHER 03-02-98
	PLOT DATE = 1/4/2008	DATE - 09-18-94	REVISED -E, GOMEZ 08-28-00

STATE OF ILLINOIS
 DEPARTMENT OF TRANSPORTATION

PAVEMENT MARKING LETTERS AND SYMBOLS FOR TRAFFIC STAGING			
SCALE: NONE	SHEET NO. 1	OF 1 SHEETS	STA. TO STA.

F.A.U. RTE.	SECTION	COUNTY	TOTAL SHEETS	SHEET NO.
1313	00-00241-00-CH	COOK	47	34
TC-16			CONTRACT NO. 63734	
FED. ROAD DIST. NO. 1 ILLINOIS FED. AID PROJECT				

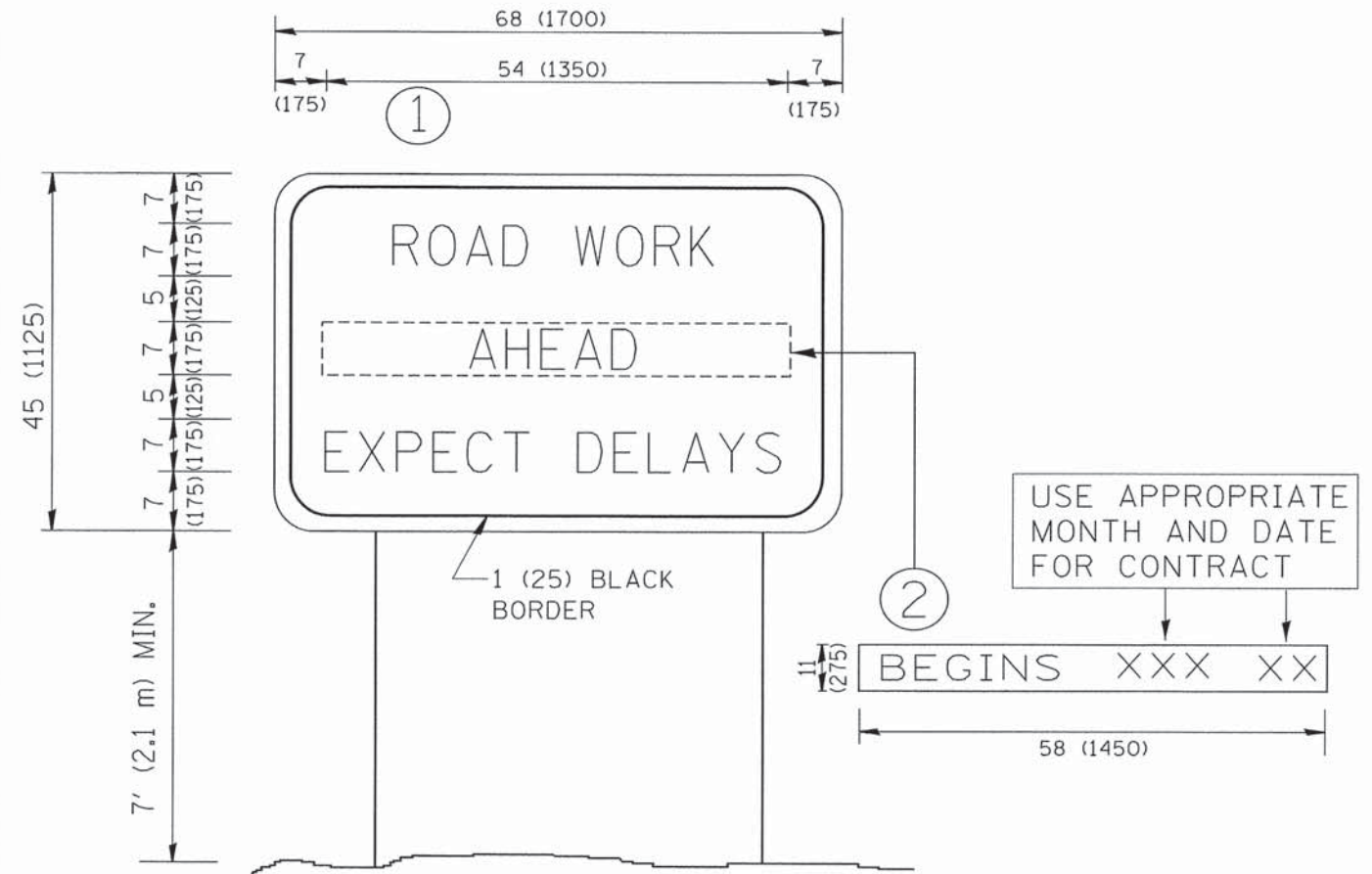

NOTES:

1. USE BLACK LETTERING ON ORANGE BACKGROUND.
2. ERECT SIGNS IN ADVANCE OF THE LOCATION FOR THE "ROAD CONSTRUCTION AHEAD" SIGN AT LOCATIONS AS DIRECTED BY THE ENGINEER.
3. ERECT SIGN ① WITH INSTALLED PANEL ② ONE WEEK PRIOR TO THE START OF CONSTRUCTION.
4. REMOVE PANEL ② SOON AFTER THE START OF CONSTRUCTION.
5. SEE SPECIAL PROVISION FOR "TEMPORARY INFORMATION SIGNING" FOR ADDITIONAL INFORMATION.
6. ONE SIGN ASSEMBLY EQUALS 25.70 SQ. FT. (2.3 SQ. M.)
7. SHALL BE PAID FOR AS TEMPORARY INFORMATION SIGNING.

ALL DIMENSIONS ARE IN INCHES (MILLIMETERS) UNLESS OTHERWISE SHOWN.

FILE NAME = W:\diststd\22x34\te22.dgn	USER NAME = goglieno	DESIGNED - DRAWN -	REVISED - R. MIRS 09-15-97 REVISED - R. MIRS 12-11-97	STATE OF ILLINOIS DEPARTMENT OF TRANSPORTATION	ARTERIAL ROAD INFORMATION SIGN		F.A.U. RTE. 1313	SECTION 00-00241-00-CH	COUNTY COOK	TOTAL SHEETS 47	SHEET NO. 35
	PLOT SCALE = 50.000 ' / IN.	CHECKED -	REVISED - T. RAMMACHER 02-02-99		SCALE: NONE	SHEET NO. 1 OF 1 SHEETS	STA.	TC-22		CONTRACT NO. 63734	
	PLOT DATE = 1/4/2000	DATE -	REVISED - C. JUCLUS 01-31-07		FED. ROAD DIST. NO. 1 [ILLINOIS] FED. AID PROJECT						



3.0" RADIUS, 0.5" BORDER, WHITE ON GREEN; REFLECTORIZED
 "DRIVEWAY" D; "ENTRANCE" D; STANDARD ARROW CUSTOM 12.0" x 5.0"

NOTES:

1. HALF OF THE SIGNS WILL REQUIRE A LEFT HAND FACING ARROW.
2. TWO SIGNS SHALL BE USED AT EACH COMMERCIAL ENTRANCE
 PLACED BACK-TO-BACK: ONE WITH A RIGHT HAND ARROW (SHOWN)
 SHALL BE PLACED ON THE NEAR RIGHT SIDE THE DRIVEWAY
 AND ONE WITH A LEFT HAND ARROW SHALL BE PLACED ON THE
 FAR LEFT SIDE OF THE DRIVEWAY.
3. SIGNS TO BE PAID FOR AS ITEM "TEMPORARY INFORMATION SIGNING".

FILE NAME = W:\distatd\22x34\tc26.dgn	USER NAME = gegjrenabt	DESIGNED -	REVISED - C. JUCIUS 02-15-07
		DRAWN -	REVISED -
	PLOT SCALE = 50.000 ' / IN.	CHECKED -	REVISED -
	PLOT DATE = 1/4/2008	DATE -	REVISED -

**STATE OF ILLINOIS
 DEPARTMENT OF TRANSPORTATION**

DRIVEWAY ENTRANCE SIGNING

SCALE: NONE SHEET NO. 1 OF 1 SHEETS STA. TO STA.

F.A.U. RTE. 1313	SECTION 00-00241-00-CH	COUNTY COOK	TOTAL SHEETS 47	SHEET NO. 36
TC-26		CONTRACT NO. 63734		
FED. ROAD DIST. NO. 1 [ILLINOIS] FED. AID PROJECT				

LOOP DETECTOR NOTES

- EACH PAIR OF LOOP WIRES SHALL BE PLACED IN A SEPARATE EMPTY COILABLE NONMETALLIC CONDUIT FROM THE EDGE OF PAVEMENT TO THE HANDHOLE. SPACING BETWEEN THE HOLES DRILLED IN THE PAVEMENT SHALL NOT BE LESS THAN 6" (150 mm). EMPTY COILABLE NONMETALLIC CONDUIT SHALL BE INCLUDED IN THE COST OF THE LOOP WIRE.
- THE NUMBER OF LOOP TURNS SHALL BE AS RECOMMENDED BY THE AMPLIFIER MANUFACTURER. ALL ADJACENT SIDES OF THE LOOPS SHALL BE INSTALLED IN SUCH A WAY THAT THE CURRENT FLOW IS IN THE SAME DIRECTION TO REINFORCE ITS MAGNETIC FIELDS FOR SMALL VEHICLE DETECTION.
- EACH LOOP LEAD-IN SHALL BE IDENTIFIED AND PERMANENTLY TAGGED IN THE HANDHOLE. EACH LEAD-IN CABLE TAG SHALL INDICATE THE LOCATION OF THE LOOP, LOOP ROTATION (CLOCKWISE/COUNTERCLOCKWISE), LOOP LEAD-IN DIRECTION (IN OR OUT), LOOP CABLE NUMBER AND LOCATION IN CABINET, AND NUMBER OF TURNS IN THE DETECTOR LOOPS IN WATER PROOF INK AS INDICATED ON THE DISTRICT 1 STANDARD TRAFFIC SIGNAL DESIGN DETAIL. THE CONTRACTOR SHALL MARK LOOP LOCATIONS ON RECORD DRAWINGS AND PRESENT TO THE ENGINEER AFTER FINAL INSPECTION. LOOPS SHALL BE MARKED BY LANE AND LOOP NUMBER. SEE DETAIL BELOW.
- ALL LOOP CABLE SHALL BE FASTENED WITH PLASTIC TIE WRAP TO THE HANDHOLE HOOKS.
- IN ASPHALT PAVEMENT, LOOPS SHOULD BE PLACED IN THE BINDER AND DIVEHOLES MARKED AT THE CURB WITH A SAW-CUT. THE SAW-CUT SHALL BE CUT IN ACCORDANCE WITH LOCAL AND E.P.A. DUST CONTROL REQUIREMENTS. DETECTOR LOOP(S) SHALL NOT BE INSTALLED IN WET CONDITIONS AND THE SAW-CUTS MUST BE FREE OF DEBRIS AND RESIDUE SUCH AS DUST AND WATER WHICH IS TO BE ACHIEVED BY THE USE OF COMPRESSED AIR, WIRE BRUSHING AND HEAT DRYING ACCORDING TO SEALANT MANUFACTURER REQUIREMENTS. THE DETECTOR WIRE SHALL BE HELD IN PLACE BY THE USE OF FORM WEDGES. WEDGES SHALL BE SPACED NO MORE THAN 18" (450 mm) APART.
- LOOP SPLICES SHALL BE SOLDERED USING A SOLDERING IRON. BLOW TORCHES OR OTHER DEVICES WHICH OXIDIZE COPPER CABLE SHALL NOT BE ALLOWED FOR SOLDERING OPERATIONS. SEE DETAIL BELOW RIGHT.
- PREFORMED DETECTOR LOOPS SHALL BE USED, AS SHOWN ON THE PLANS, WHERE NEW CONCRETE PAVEMENT IS PROPOSED. THE INSTALLATION OF PREFORMED LOOPS SHALL BE IN ACCORDANCE WITH THE DISTRICT 1 SPECIFICATIONS OR AS DIRECTED BY THE ENGINEER.

LOOP LEAD-IN CABLE TAG

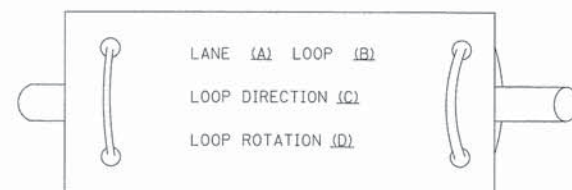

- LANE #1 IS THE LANE CLOSEST TO THE CENTERLINE OF THE ROADWAY
- LOOP #1 IS THE LOOP IN THE LANE CLOSEST TO THE INTERSECTION.
- LABEL LOOP CABLE "IN" OR LOOP CABLE "OUT".
- LABEL LOOP CABLE CLOCKWISE OR LOOP CABLE COUNTERCLOCKWISE.

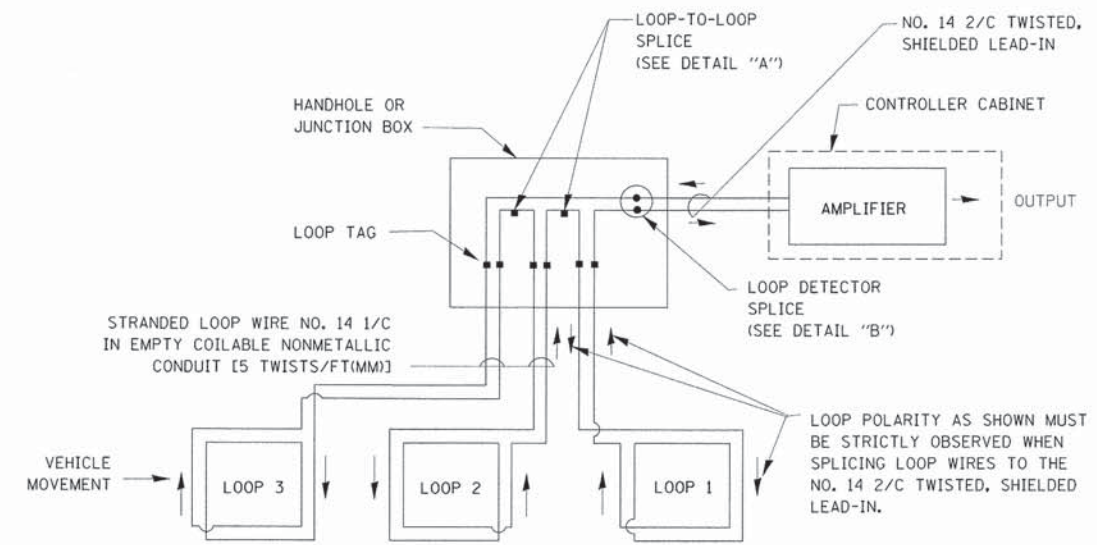

DETECTOR LOOP WIRING SCHEMATIC

- LOOPS SHALL BE SPLICED IN SERIES.
- SAW-CUTS SHALL BE A MINIMUM WIDTH OF 5/16" (8 mm).
- SAW-CUT DEPTHS SHALL BE 3" (75 mm). IF IN CONCRETE, THE SAW-CUT DEPTH SHALL BE TO THE TOP OF THE REINFORCEMENT.
- LOOP CORNERS SHALL BE DRILLED WITH A 2" (50 mm) DIAMETER CORE.

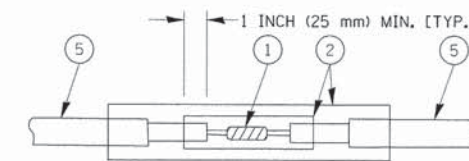

DETAIL "A"
LOOP-TO-LOOP SPLICE

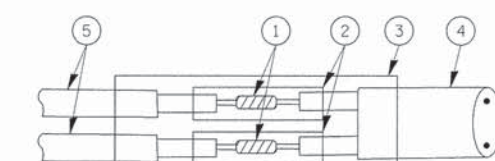

DETAIL "B"
LOOP-TO-CONTROLLER SPLICE

TYPE I LOOP

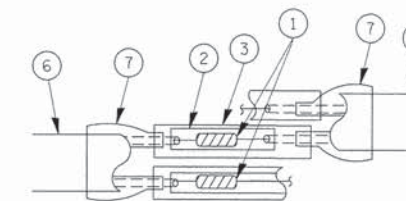

DETAIL "A"
LOOP-TO-LOOP SPLICE

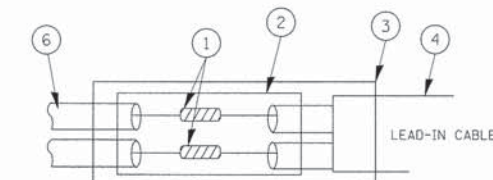

DETAIL "B"
LOOP-TO-CONTROLLER SPLICE

LOOP DETECTOR SPLICE

- WESTERN UNION SPLICE SOLDERED WITH ROSIN CORE FLUX. ALL EXPOSED SURFACES OF THE SOLDER SHALL BE SMOOTH.
- WCSMW 30/100 HEAT SHRINK TUBE, MINIMUM LENGTH 3" (75 mm), UNDERWATER GRADE.
- WCS 200/750 HEAT SHRINK TUBE, MINIMUM LENGTH 6" (150 mm), UNDERWATER GRADE.
- NO. 14 2/C TWISTED, SHIELDED CABLE.
- LOOP CONDUCTOR WITH FLEXIBLE PLASTIC TUBE.
- PRE-FORMED LOOP
- XL POLYOLEFIN 2 CONDUCTOR BREAKOUT SEALS, TYCO CBR-2 OR APPROVED EQUAL

FILE NAME =	USER NAME = bawerdl	DESIGNED - DAD	REVISED -	STATE OF ILLINOIS DEPARTMENT OF TRANSPORTATION	DISTRICT ONE STANDARD TRAFFIC SIGNAL DESIGN DETAILS	F.A.U. RTE. 1313	SECTION 00-00241-00-CH	COUNTY COOK	TOTAL SHEETS 47	SHEET NO. 37	
ct:\pe_work\PW1001\BAUERDL\0108315\ts05.dgn	DRAWN - BCK	CHECKED - DAD	REVISED -			TS-05		CONTRACT NO. 63734			
PLOT SCALE = 50.0000" / IN.	DATE = 10-28-09	REVISOR -	REVISOR -			FED. ROAD DIST. NO. 1 [ILLINOIS] FED. AID PROJECT					
PLOT DATE = 11/4/2009						SCALE: NONE SHEET NO. 1 OF 6 SHEETS STA. TO STA.					

TRAFFIC SIGNAL MAST ARM AND SIGNAL POST

MAST ARM MOUNTED SIGNALS IN EXISTING, PROPOSED OR FUTURE SIDEWALK/BICYCLE PATH AREA. INTERSECTION SHOWN WITH PEDESTRIAN SIGNALS AND PEDESTRIAN PUSHBUTTON DETECTORS.

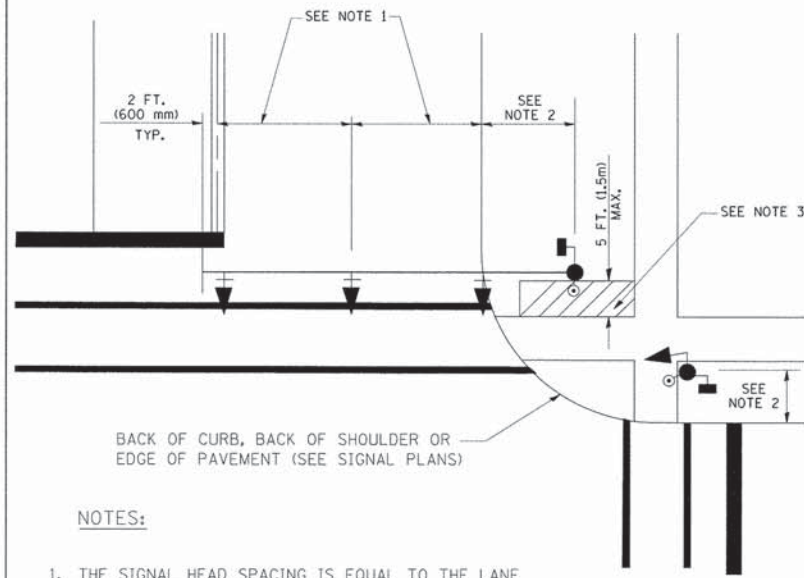

NOTES:

1. THE SIGNAL HEAD SPACING IS EQUAL TO THE LANE WIDTH OR AS SHOWN ON THE TRAFFIC SIGNAL PLAN.
2. REFER TO THE TRAFFIC SIGNAL EQUIPMENT OFFSET TABLE.
3. PROVIDE A LEVEL ALL-WEATHER SURFACE (CONCRETE SIDEWALK, ASPHALT BICYCLE PATH SURFACE OR MATCHING MATERIAL TO THE ADJACENT SURFACE) UP TO THE MAST ARM SHAFT OR THE SIGNAL POST.
4. THE FACE OF THE PEDESTRIAN PUSHBUTTON SHALL BE PARALLEL TO THE CROSSWALK TO BE USED.
5. THE LOCATIONS AND INSTALLATION OF PEDESTRIAN SIGNAL HEADS AND PEDESTRIAN PUSHBUTTONS SHALL MEET THE REQUIREMENTS OF THE MUTCD AND INFORMATION FOUND IN THE "AMERICANS WITH DISABILITIES ACT ACCESSIBILITY GUIDELINES FOR BUILDINGS AND FACILITIES."

PEDESTRIAN SIGNAL POST AND PEDESTRIAN PUSH BUTTON POST

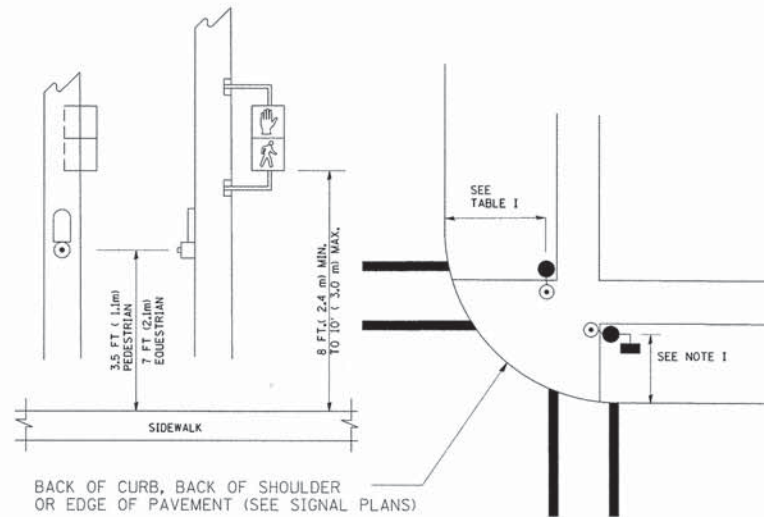

NOTES:

1. REFER TO THE TRAFFIC SIGNAL EQUIPMENT OFFSET TABLE.
2. PROVIDE A LEVEL ALL-WEATHER SURFACE (CONCRETE SIDEWALK, ASPHALT BICYCLE PATH SURFACE OR MATCHING MATERIAL TO THE ADJACENT SURFACE) UP TO THE PEDESTRIAN SIGNAL POST OR THE PEDESTRIAN PUSH BUTTON POST.
3. THE FACE OF THE PEDESTRIAN PUSHBUTTON SHALL BE PARALLEL TO THE CROSSWALK TO BE USED.
4. THE LOCATIONS AND INSTALLATION OF PEDESTRIAN SIGNAL HEADS AND PEDESTRIAN PUSHBUTTONS SHALL MEET THE REQUIREMENTS OF THE MUTCD AND INFORMATION FOUND IN THE "AMERICANS WITH DISABILITIES ACT ACCESSIBILITY GUIDELINES FOR BUILDINGS AND FACILITIES."

RECOMMENDED PUSHBUTTON LOCATIONS

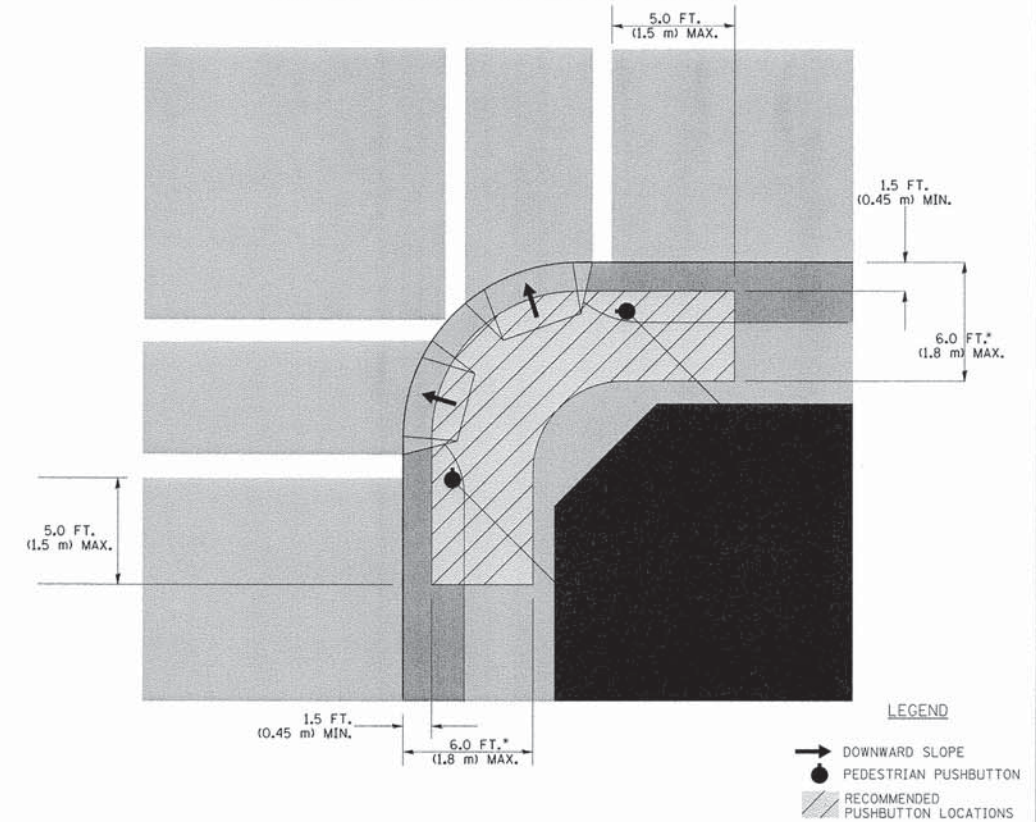

- WHERE THERE ARE CONSTRAINTS THAT MAKE IT IMPRACTICAL TO PLACE THE PEDESTRIAN PUSHBUTTON BETWEEN 1.5 FT (0.45 m) AND 6 FT (1.8 m) FROM THE EDGE OF THE CURB, SHOULDER, OR PAVEMENT, IT SHOULD NOT BE FURTHER THAN 10 FT (3 m) FROM THE EDGE OF CURB, SHOULDER, OR PAVEMENT.
- WHERE THERE ARE CONSTRAINTS ON A PARTICULAR CORNER THAT MAKE IT IMPRACTICAL TO PROVIDE THE 10 FT (3 m) SEPERATION BETWEEN THE TWO PEDESTRIAN PUSHBUTTONS, THE PUSHBUTTONS MAY BE PLACED CLOSER TOGETHER OR ON THE SAME POLE.

NOTES:

1. PEDESTRIAN SIGNAL HEADS SHALL BE MOUNTED WITH THE BOTTOM OF THE SIGNAL HOUSING INCLUDING BRACKETS NOT LESS THAN 8 FT (2.4 m) OR MORE THAN 10 FT (3 m) ABOVE SIDEWALK LEVEL, AND SHALL BE POSITIONED AND ADJUSTED TO PROVIDE MAXIMUM VISIBILITY AT THE BEGINNING OF THE CONTROLLED CROSSWALK.
2. THE BOTTOM OF THE SIGNAL HOUSING (INCLUDING BRACKETS) OF A VEHICULAR SIGNAL FACE THAT IS NOT LOCATED OVER A HIGHWAY SHALL BE AT LEAST 8 FT (2.4 m) BUT NOT MORE THAN 19 FT (5.8 m) ABOVE THE SIDEWALK OR, IF THERE IS NO SIDEWALK, ABOVE THE PAVEMENT GRADE AT THE CENTER OF THE ROADWAY.
3. THE BOTTOM OF THE SIGNAL HOUSING AND ANY RELATED ATTACHMENTS TO A SIGNAL FACE LOCATED OVER ANY PORTION OF A HIGHWAY SHALL BE ACCORDING TO CURRENT STATE STANDARDS 877001, 877002, 877006, 877011 AND 877012 WITH A MINIMUM OF 16 FT (5.0 m) AND A MAXIMUM OF 18 FT. (5.5 m) FROM THE HIGHEST POINT OF PAVEMENT.
4. THE BOTTOM OF THE TEMPORARY SPAN WIRE MOUNTED SIGNAL HOUSING AND ANY RELATED ATTACHMENTS TO A SIGNAL FACE LOCATED OVER ANY PORTION OF A HIGHWAY SHALL BE ACCORDING TO CURRENT STATE STANDARD 880001 WITH A MINIMUM OF 17 FT (5.18 m) FROM THE HIGHEST POINT OF PAVEMENT.
5. THE TOP OF THE SIGNAL HOUSING OF A SIGNAL FACE LOCATED OVER ANY PORTION OF A HIGHWAY SHALL NOT BE MORE THAN 25.6 FT (7.8 m) ABOVE THE PAVEMENT.

TRAFFIC SIGNAL EQUIPMENT OFFSET

TRAFFIC SIGNAL EQUIPMENT	COMBINATION CONCRETE CURB AND GUTTER (MINIMUM DISTANCE FROM BACK OF CURB TO CENTERLINE OF FOUNDATION)	SHOULDER/NON-CURBED AREA (MINIMUM DISTANCE FROM EDGE OF PAVEMENT TO CENTERLINE OF FOUNDATION)
TRAFFIC SIGNAL MAST ARM POLE	6 FT (1.8m)	SHOULDER WIDTH + 2 FT (0.6m), MINIMUM 10 FT (3.0m)
TRAFFIC SIGNAL POST	4 FT (1.2m)	SHOULDER WIDTH + 2 FT (0.6m), MINIMUM 10 FT (3.0m)
PEDESTRIAN SIGNAL POST	4 FT (1.2m)	SHOULDER WIDTH + 2 FT (0.6m), MINIMUM 10 FT (3.0m)
PEDESTRIAN PUSHBUTTON POST	4 FT (1.2m)	SHOULDER WIDTH + 2 FT (0.6m), MINIMUM 10 FT (3.0m)
TEMPORARY WOOD POLE	6 FT (1.8m)	SHOULDER WIDTH + 2 FT (0.6m), MINIMUM 10 FT (3.0m)
CONTROLLER CABINET	6 FT (1.8m) MINIMUM DISTANCE SEE NOTE 2	SHOULDER WIDTH + 6 FT (1.8m), MINIMUM 16 FT (4.9m) SEE NOTE 3.
SERVICE INSTALLATION, GROUND MOUNT	6 FT (1.8m) MINIMUM DISTANCE SEE NOTE 2	SHOULDER WIDTH + 6 FT (1.8m), MINIMUM 16 FT (4.9m) SEE NOTE 3.

NOTES:

1. CONTACT THE "AREA TRAFFIC SIGNAL MAINTENANCE AND OPERATIONS ENGINEER" FOR ASSISTANCE IN LOCATING THE TRAFFIC SIGNAL EQUIPMENT WHEN THERE ARE CONFLICTS WITH DITCHES OR THE MINIMUM OFFSET DISTANCES CANNOT BE MET.
2. MINIMUM DISTANCE FROM THE BACK OF CURB TO THE ROADWAY SIDE OF THE FOUNDATION.
3. MINIMUM DISTANCE FROM THE EDGE OF PAVEMENT TO THE ROADWAY SIDE OF THE FOUNDATION.
4. ANY CHANGES TO THE OFFSETS OF THE FOUNDATIONS, FROM THE MINIMUM DISTANCES LISTED IN THE "TRAFFIC SIGNAL EQUIPMENT OFFSET" CHART AND THE TRAFFIC SIGNAL INSTALLATION PLAN, COULD EFFECT THE PLACEMENT OF THE SIGNAL HEADS, PEDESTRIAN SIGNAL HEADS AND THE PEDESTRIAN PUSHBUTTONS. THE SIGNAL HEAD PLACEMENT ON THE MAST ARMS SHALL REMAIN AS PER THE TRAFFIC SIGNAL INSTALLATION PLAN AND THE "TRAFFIC SIGNAL MAST ARM AND SIGNAL POST" DETAIL ABOVE. THE PROPOSED MAST ARM LENGTHS MAY NEED TO BE REVISED TO MEET THE ABOVE REQUIREMENTS. THE PEDESTRIAN SIGNAL HEADS AND PEDESTRIAN PUSHBUTTONS MUST MEET THE REQUIREMENTS UNDER THE DETAILS ON THIS SHEET.

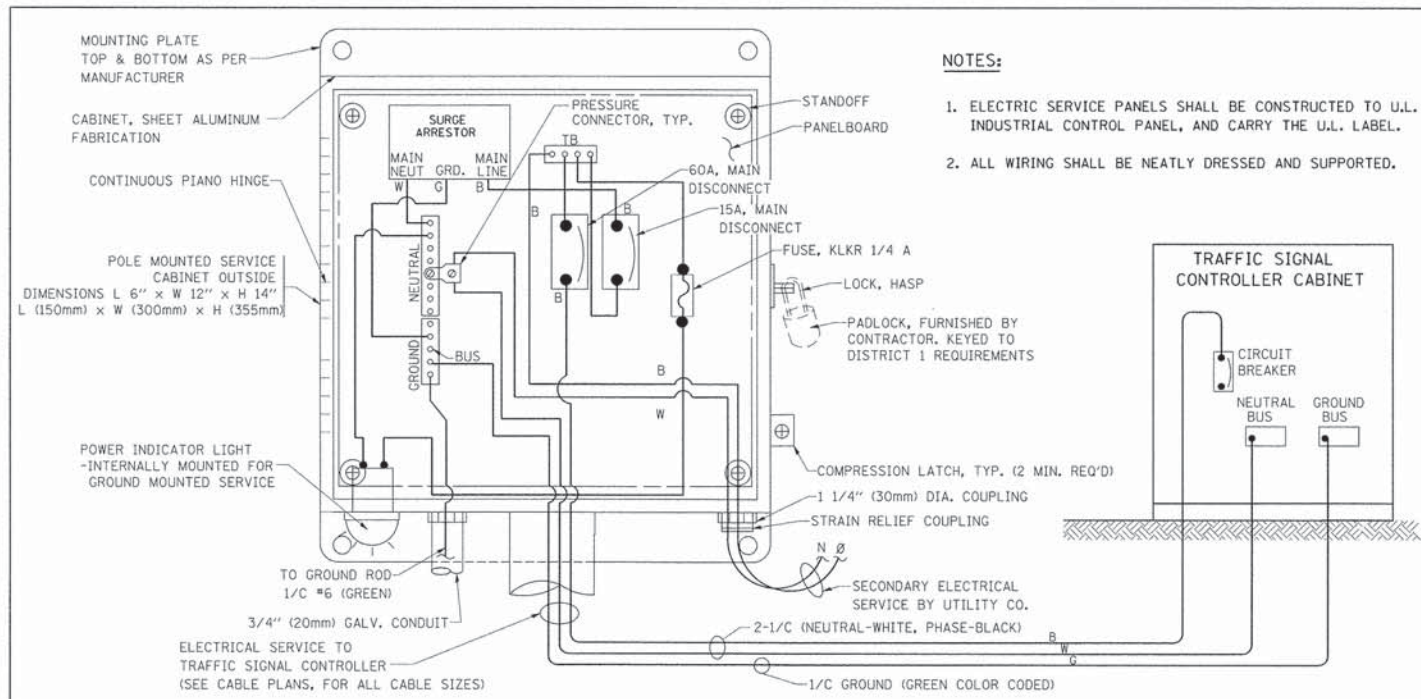

ELECTRICAL SERVICE - PANEL DIAGRAM (TYPICAL FOR POLE AND GROUND MOUNTED SERVICE)
SERVICE INSTALLATION POLE MOUNT (SHOWN)
 (NOT TO SCALE)

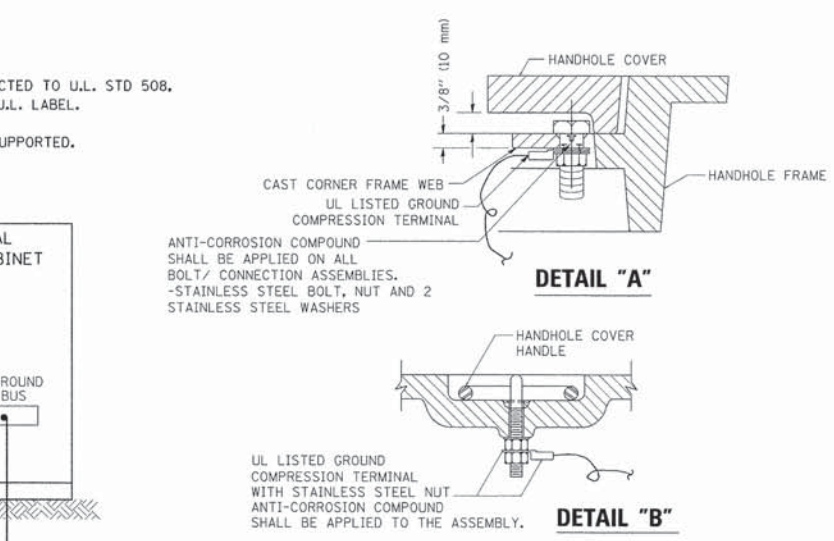
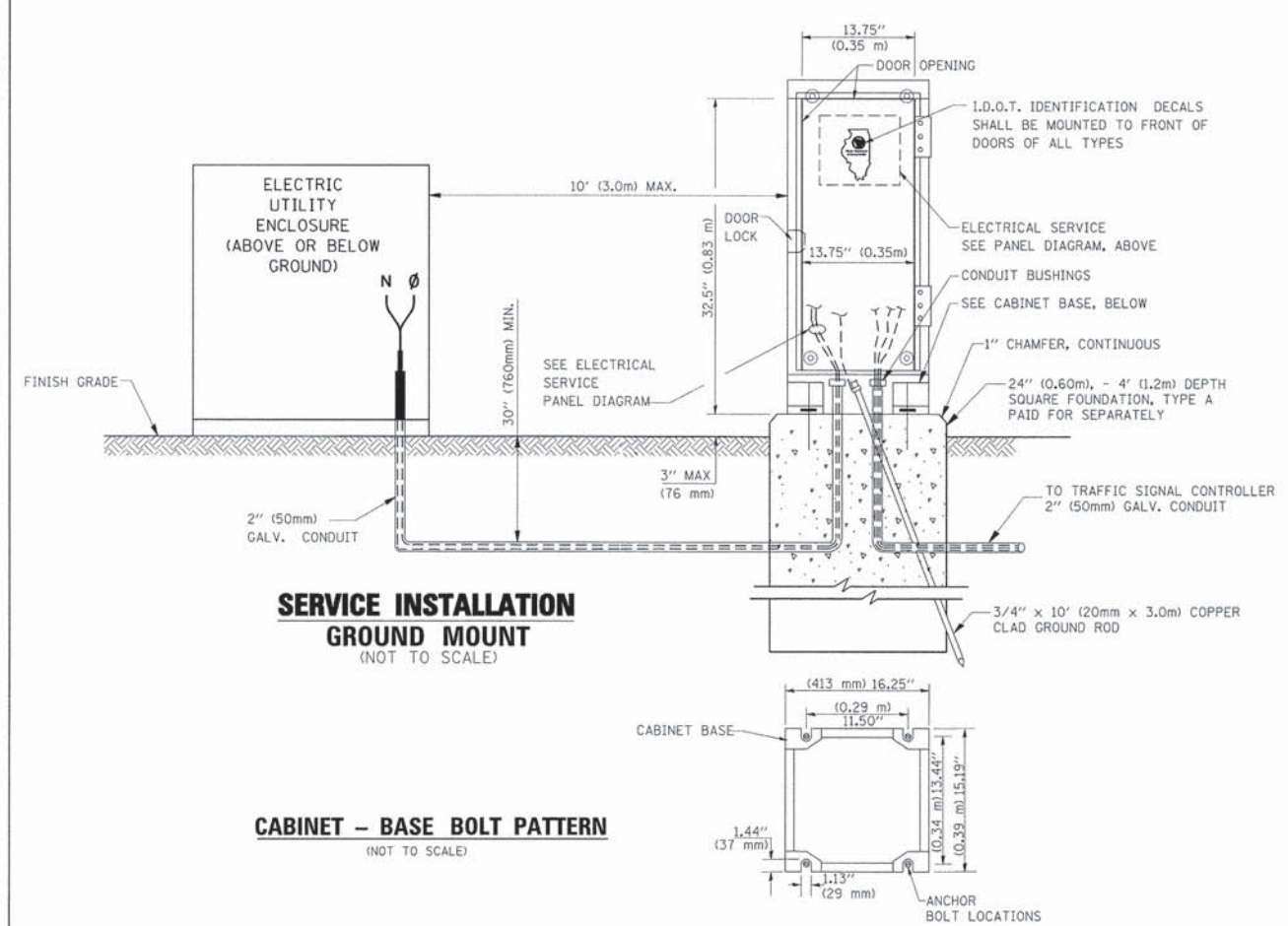

NOTES:

GROUNDING SYSTEM

1. THE GROUNDING SYSTEM SHALL CONSIST OF AN INSULATED CONDUCTOR TYPE XLP, NO. 6 A.W.G., STRANDED COPPER TO BE INSTALLED IN RACEWAYS. THE GROUNDING CABLE SHALL BE INSTALLED IN A CONTINUOUS MANNER AS SHOWN ON THE CABLE PLAN PROVIDED. ALL GROUNDING CONDUCTORS SHALL BE BONDED TO METAL ENCLOSURE (HANDHOLE, POST, MAST ARM, CONTROLLER, ETC.). GROUND ROD SHALL BE 3/4" DIA. x 10'-0" (20mm x 3.0m) LONG, COPPER CLAD. ONE GROUND ROD SHALL BE INSTALLED AT ALL POST FOUNDATIONS, POLE FOUNDATIONS, CONTROLLER CABINET FOUNDATION AND ELECTRICAL SERVICE INSTALLATION AS INDICATED ON THE CABLE PLAN. IF THERE ARE ANY SPECIAL CONDITIONS SUCH AS SUB-SURFACE CONDITIONS OR INSTALLATION PROBLEMS, THE RESIDENT ENGINEER SHALL BE NOTIFIED OR CONTACT THE BUREAU OF TRAFFIC, ILLINOIS DEPARTMENT OF TRANSPORTATION DISTRICT ONE AT (847) 705-4139.
2. THE NEUTRAL CONDUCTOR AND THE GROUND CONDUCTOR SHALL BE CONNECTED IN THE SERVICE INSTALLATION. AT NO OTHER POINT IN THE TRAFFIC SIGNAL SYSTEM SHALL THE NEUTRAL AND GROUND CONDUCTORS BE CONNECTED.
3. ALL EQUIPMENT GROUNDING CONDUCTORS SHALL TERMINATE AT THE GROUND BUS IN THE CONTROLLER CABINET.
4. THE CONTRACTOR SHALL PROVIDE A GROUND CABLE WITH CONNECTORS BETWEEN THE HANDHOLE COVER AND HANDHOLE FRAME.

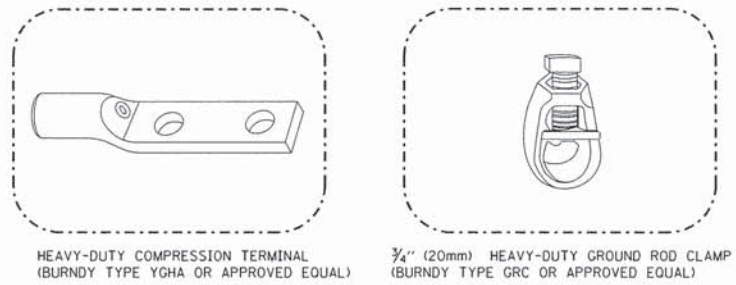
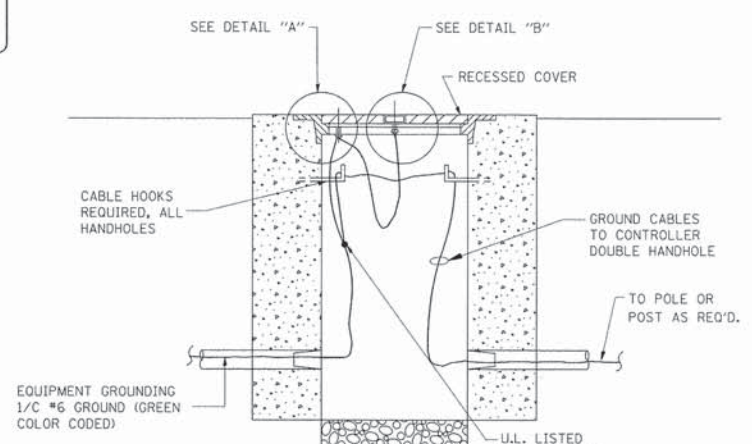

NOTES:

- ALL CLAMPS SHALL BE BRONZE OR COPPER, UL APPROVED.
- GROUND CABLE SHALL BE LOOPED OVER HOOKS IN THE HANDHOLES 6.5' (2.0m) SLACK SHALL BE PROVIDED IN SINGLE HANDHOLES 13' (4.0m) OF SLACK SHALL BE PROVIDED IN DOUBLE HANDHOLES, 5' (1.4m) OF SLACK SHALL BE PROVIDED BETWEEN FRAME AND COVER.

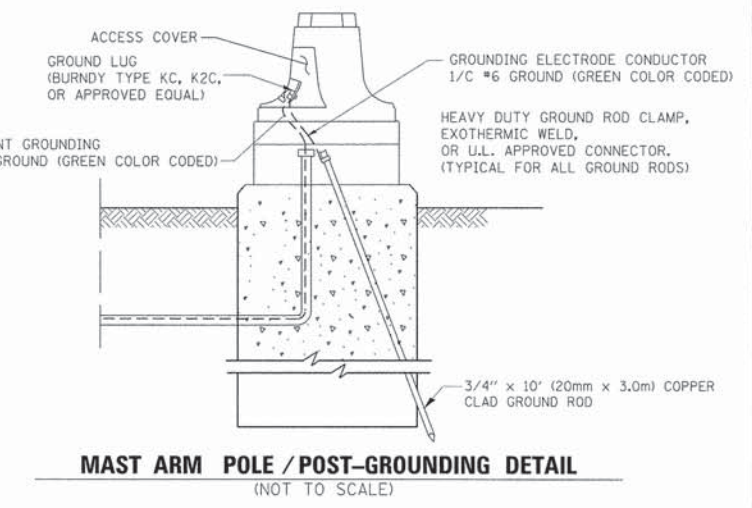
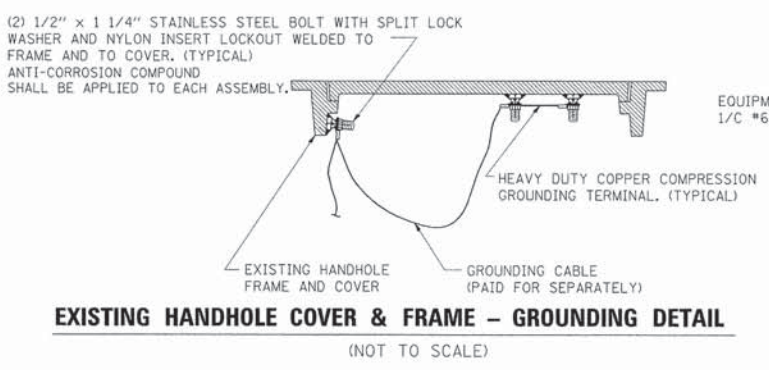

FILE NAME =	USER NAME = bauerl	DESIGNED - DAD	REVISED -
et\pwork\FW1001\BAUERL\d0108315\ts05.dgn		DRAWN - BCK	REVISED -
		CHECKED - DAD	REVISED -
		DATE - 10-28-09	REVISED -

STATE OF ILLINOIS
DEPARTMENT OF TRANSPORTATION

DISTRICT ONE
STANDARD TRAFFIC SIGNAL DESIGN DETAILS

SCALE: NONE SHEET NO. 3 OF 6 SHEETS STA. TO STA.

F.A.U. RTE.	SECTION	COUNTY	TOTAL SHEETS	SHEET NO.
1313	00-00241-00-CH	COOK	47	39
TS-05		CONTRACT NO. 63734		
FED. ROAD DIST. NO. 1 [ILLINOIS] FED. AID PROJECT				

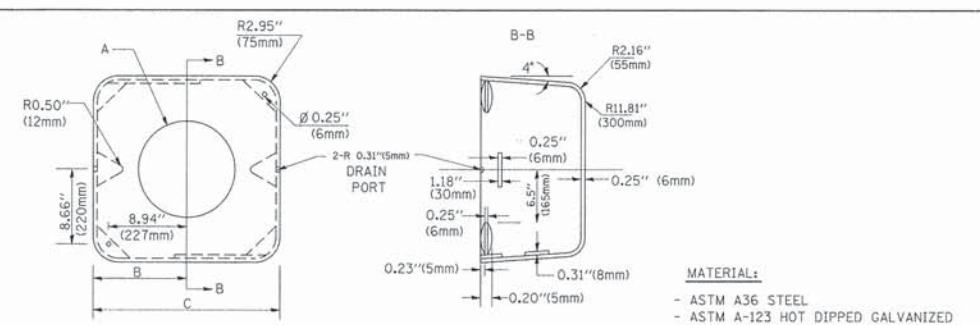
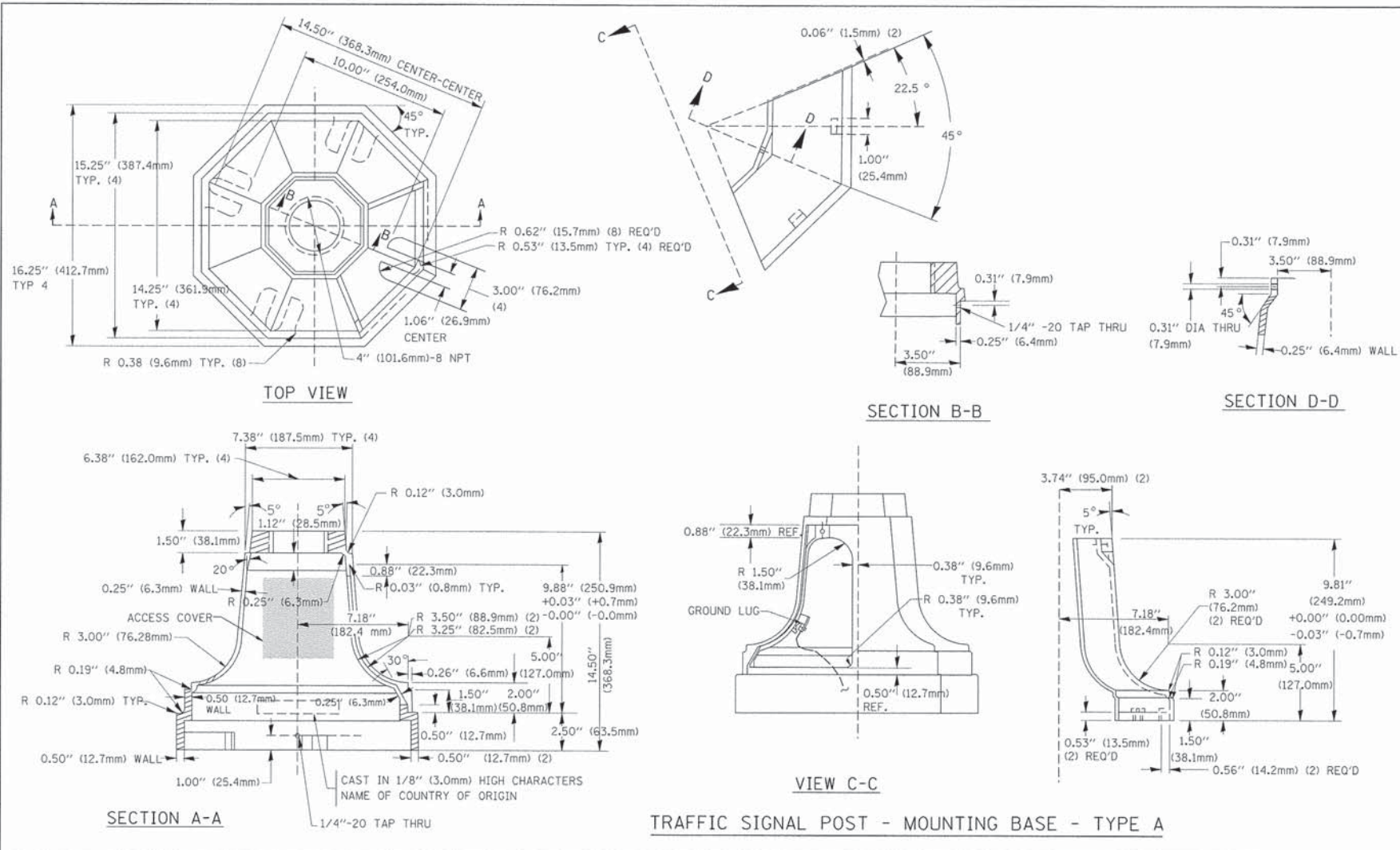

A	B	C	HEIGHT	WEIGHT
VARIES	9.5"(241mm)	19"(483mm)	7"(178mm) - 12"(300mm)	53 lbs (24kg)
VARIES	10.75"(273mm)	21.5"(546mm)	7"(178mm) - 12"(300mm)	68 lbs (31 kg)
VARIES	13.0"(330mm)	26"(660mm)	7"(178mm) - 12"(300mm)	81 lbs (37 kg)
VARIES	18.5"(470mm)	37"(940mm)	7"(178mm) - 12"(300mm)	126 lbs (57 kg)

- NOTES:**
- DIMENSION "A" IS EQUAL TO THE DIAMETER OF THE MAST ARM POLE AT THE TOP OF THE SHROUD. THE SHROUD SHALL BE TIGHT TO THE MAST ARM POLE.
 - THE SUPPLIER SHALL VERIFY THE ABOVE DIMENSIONS BASED ON MAST ARM REQUIREMENTS.
 - THE HEIGHT OF THE SHROUD SHALL COVER THE ANCHOR BOLTS, NUTS AND MAST ARM POLE BASE.

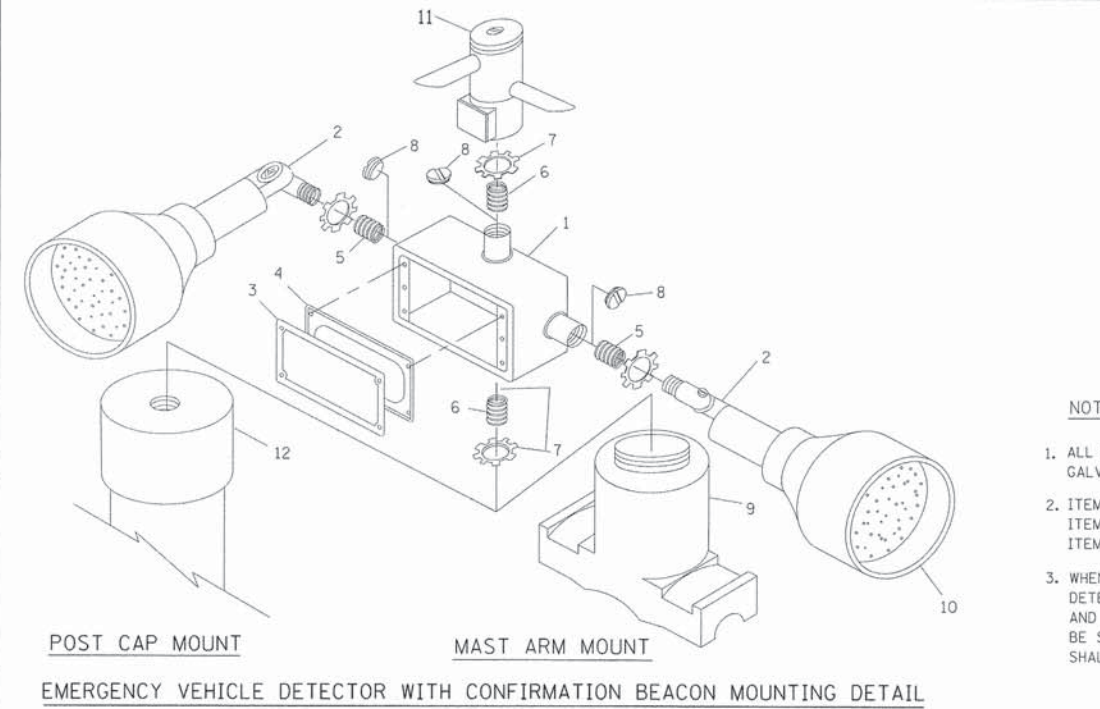
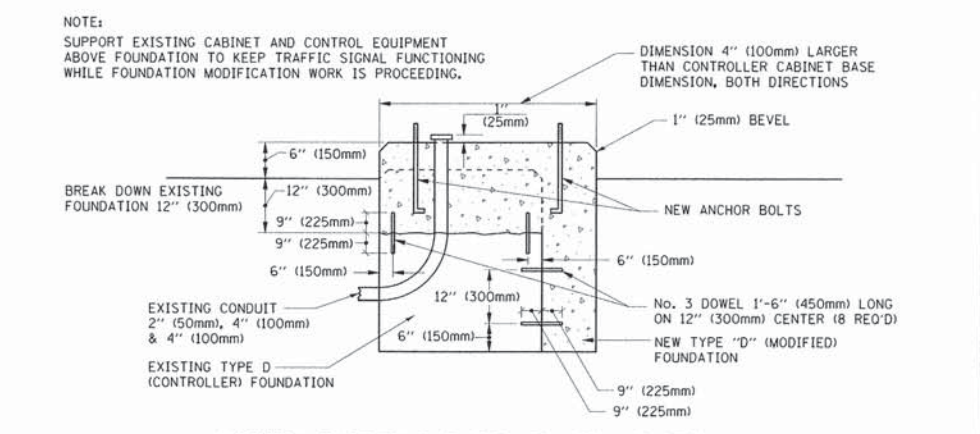

- NOTES:**
- ALL ELECTRICAL ITEMS, EXCEPT ITEMS #2 AND #11 SHALL BE ALUMINUM OR GALVANIZED
 - ITEM #1- OZ/GEDNEY FSX-1-50 OR EQUIVALENT
 ITEM #2- MULBERRY CON-O-SHADE LAMP SHIELD OR EQUIVALENT
 ITEM #9- "BAND-IT" SADDLE BRACKET OR EQUIVALENT
 - WHEN POST MOUNTING IS SPECIFIED, ITEM #9 SHALL NOT BE REQUIRED. THE DETECTION UNIT SHALL BE MOUNTED DIRECTLY ON TOP OF THE CAP BY DRILLING AND TAPPING A 3/4" (19 mm) HOLE WITH PIPE THREADS. THE POST CAP SHALL EITHER BE SCREWED TO THE TOP OF THE POST OR A MINIMUM OF 3 TIGHTENING SCREWS SHALL BE REQUIRED ON EACH CAP.

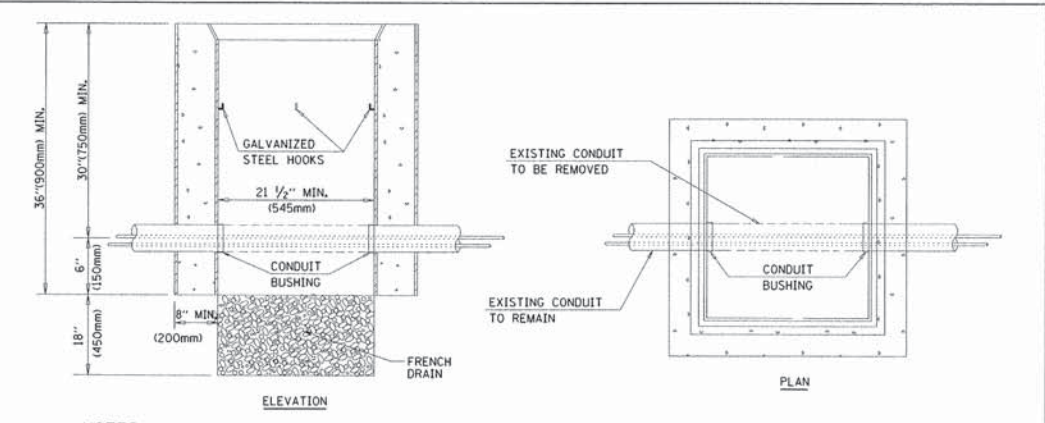

- NOTES:**
- HANDHOLE CONSTRUCTED PER STATE STANDARD 814001.
 - REMOVAL OF THE EXISTING CONDUIT FROM THE HANDHOLE AND THE INSTALLATION OF THE CONDUIT BUSHINGS SHALL BE INCIDENTAL TO THE HANDHOLE.

HANDHOLE TO INTERCEPT EXISTING CONDUIT

FILE NAME =	USER NAME = baourd	DESIGNED - DAD	REVISED -
c:\pwwork\p\WIDOT\BAUER\LD\0108315\ts05.dgn		DRAWN - BCK	REVISED -
		CHECKED - DAD	REVISED -
		DATE - 10-28-09	REVISED -

**STATE OF ILLINOIS
 DEPARTMENT OF TRANSPORTATION**

**DISTRICT ONE
 STANDARD TRAFFIC SIGNAL DESIGN DETAILS**

SCALE: NONE SHEET NO. 4 OF 6 SHEETS STA. TO STA.

F.A.U. R.T.E. 1313	SECTION 00-00241-00-CH	COUNTY COOK	TOTAL SHEETS 47	SHEET NO. 40
TS-05		CONTRACT NO. 63734		
FED. ROAD DIST. NO. 1 [ILLINOIS] FED. AID PROJECT				

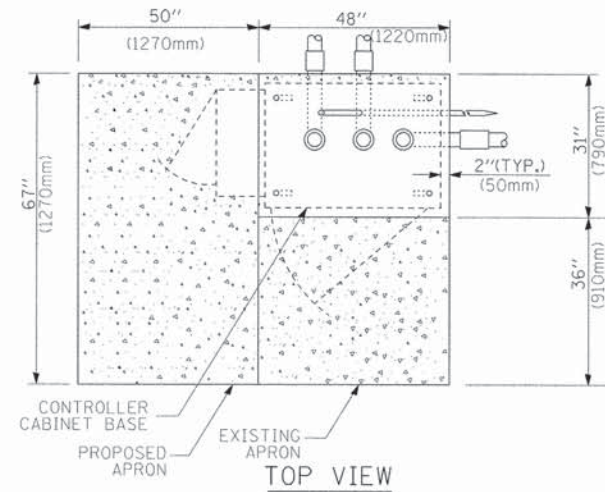

TOP VIEW

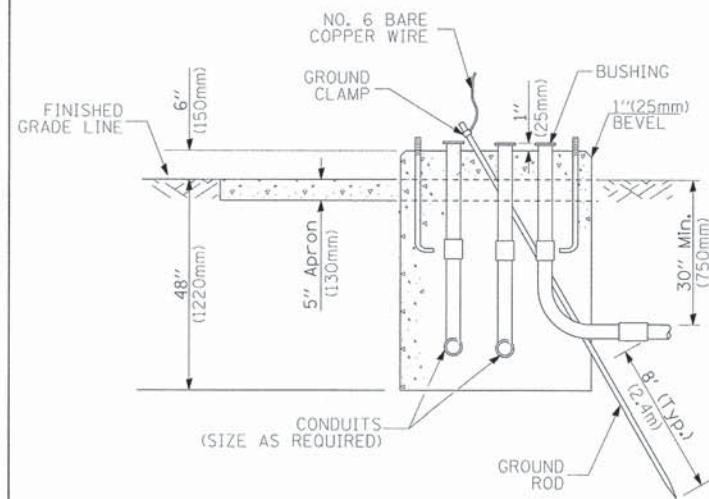

TYPE D
FOR GROUND MOUNTED
CONTROLLER CABINET
AND UPS BATTERY CABINET

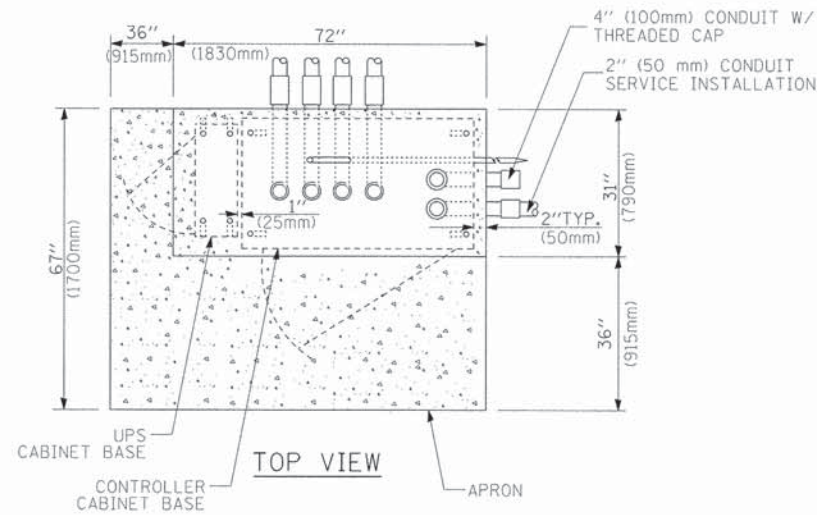

TOP VIEW

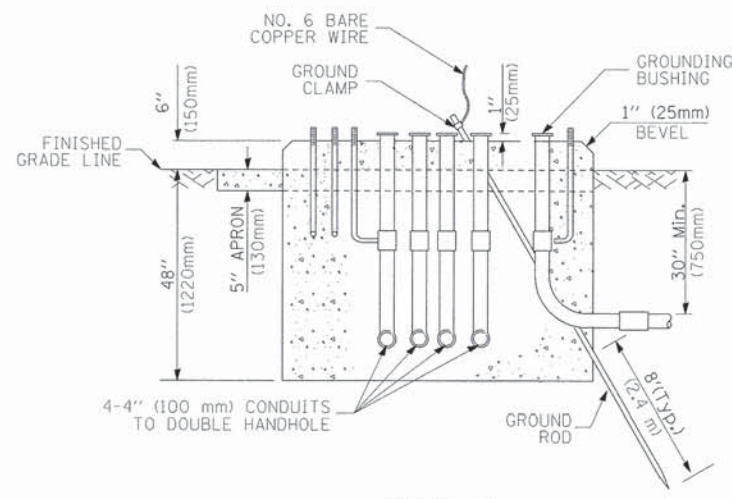

TYPE C
FOR GROUND MOUNTED
CONTROLLER CABINET
AND UPS BATTERY CABINET

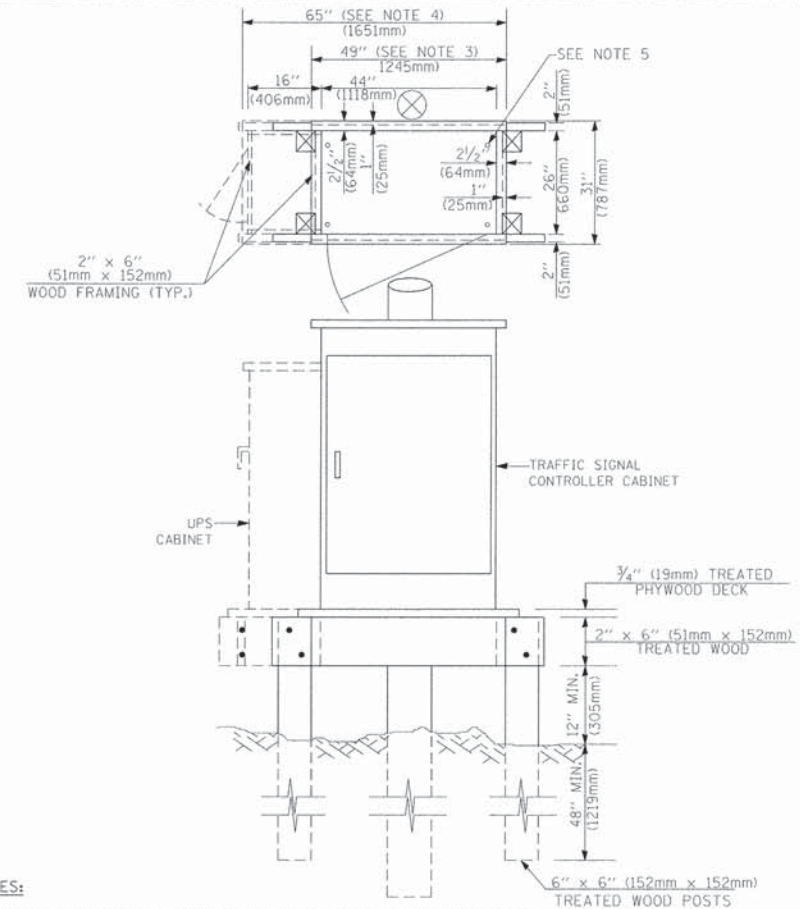

NOTES:

- BASED ON CONTROLLER CABINET TYPE IV WITH BASE DIMENSIONS OF 26" x 44" (660mm x 1118mm). ADJUST PLATFORM SIZE TO FIT CABINET BASE DIMENSIONS BEING SUPPLIED.
- BASED ON UNINTERRUPTIBLE POWER SUPPLY CABINET WITH BASE DIMENSIONS OF 16" x 25" (406mm x 635mm). ADJUST PLATFORM SIZE TO FIT CABINET BASE DIMENSIONS BEING SUPPLIED.
- PLATFORM SIZE FOR CONTROLLER CABINET TYPE IV.
- PLATFORM SIZE FOR CONTROLLER CABINET TYPE IV AND UNINTERRUPTIBLE POWER SUPPLY CABINET.
- DRILLED HOLES THROUGH THE PLATFORM BASE TO MATCH THE CONTROLLER CABINET BOLT TEMPLATE. FASTEN THE CONTROLLER CABINET TO THE PLATFORM WITH CARRIAGE BOLTS, WASHERS AND NUTS.
- FASTEN ALL SUPPORT WOOD FRAMING TO THE WOOD POSTS WITH 2 LAG SCREWS FOR EACH CONNECTION.

TEMPORARY SIGNAL CONTROLLER
WOOD SUPPORT PLATFORM

CABLE SLACK LENGTH	FEET	METER
HANDHOLE	6.5	2.0
DOUBLE HANDHOLE	13.0	4.0
SIGNAL POST	2.0	0.6
MAST ARM	2.0	0.6
CONTROLLER CABINET	1.5	0.5
FIBER OPTIC AT CABINET	13.0	4.0
ELECTRIC SERVICE AT (CABINET OR SERVICE LOCATION)	1.5	0.5
GROUND CABLE (SIGNAL POST, MAST ARM, CABINET)	1.5	0.5
GROUND CABLE (BETWEEN FRAME AND COVER)	5.0	1.6

CABLE SLACK

VERTICAL CABLE LENGTH	FEET	METER
MAST ARM POLE (MAST ARM MOUNTED SIGNAL HEAD) (L = MAST ARM LENGTH - DISTANCE TO SIGNAL HEAD FROM END OF ARM)	20.0+L	6.0+L
BRACKET MOUNTED (MAST ARM POLE OR SIGNAL POLE)	13.0	4.0
PEDESTRIAN PUSH BUTTON	6.0	2.0
SERVICE INSTALLATION POLE MOUNT TO SERVICE DROP	13.5	4.1
SERVICE INSTALLATION POLE MOUNT TO GROUND	13.5	4.1
SERVICE INSTALLATION GROUND MOUNT	6.0	2.0
FOUNDATION (SIGNAL POST, MAST ARM POLE, CONTROLLER CABINET, SERVICE-GROUND MOUNT)	3.0	1.0

VERTICAL CABLE LENGTH

FOUNDATION	DEPTH
TYPE A - Signal Post	4'-0" (1.2m)
TYPE C - CONTROLLER W/ UPS	4'-0" (1.2m)
TYPE D - CONTROLLER	4'-0" (1.2m)
SERVICE INSTALLATION, GROUND MOUNT, TYPE A - SQUARE	4'-0" (1.2m)

DEPTH OF FOUNDATION

MAST ARM LENGTH	FOUNDATION DEPTH	FOUNDATION DIAMETER	SPIRAL DIAMETER	QUANTITY OF REBARS	SIZE OF REBARS
Less than 30' (9.1 m)	10'-0" (3.0 m)	30" (750mm)	24" (600mm)	8	6(19)
Greater than or equal to 30' (9.1 m) and less than 40' (12.2 m)	13'-6" (4.1 m)	30" (750mm)	24" (600mm)	8	6(19)
Greater than or equal to 40' (12.2 m) and less than 50' (15.2 m)	11'-0" (3.4 m)	36" (900mm)	30" (750mm)	12	7(22)
Greater than or equal to 50' (15.2 m) and up to 55' (16.8 m)	13'-0" (4.0 m)	36" (900mm)	30" (750mm)	12	7(22)
Greater than or equal to 55' (16.8 m) and up to 56' (16.8 m) and less than 65' (19.8 m)	15'-0" (4.6 m)	36" (900mm)	30" (750mm)	12	7(22)
Greater than or equal to 56' (16.8 m) and less than 65' (19.8 m)	21'-0" (6.4 m)	42" (1060mm)	36" (900mm)	16	8(25)
Greater than or equal to 65' (19.8 m) and up to 75' (22.9 m)	25'-0" (7.6 m)	42" (1060mm)	36" (900mm)	16	8(25)

NOTES:

- These foundation depths are for sites which have cohesive soils (clayey silt, sandy clay, etc.) along the length of the shaft, with an average Unconfined Compressive Strength (Qu) > 1.0 tsf (100 kpa). This strength shall be verified by boring data prior to construction or with testing by the Engineer during foundation drilling. The Bureau of Bridges & Structures should be contacted for a revised design if other conditions are encountered.
- Combination mast arm assemblies under 55 feet (16.8 m) shall use 36" (900 mm) diameter foundations.
- Combination mast arm assemblies under 56 feet (16.8 m) through 75 feet (22.9 m) shall use 42" (1060 mm) diameter foundations.
- For mast arm assemblies with dual arms refer to state standard 878001.

DEPTH OF MAST ARM FOUNDATIONS, TYPE E

TRAFFIC SIGNAL LEGEND

ITEM	REMOVAL	EXISTING	PROPOSED	ITEM	REMOVAL	EXISTING	PROPOSED	ITEM	REMOVAL	EXISTING	PROPOSED
CONTROLLER CABINET				EMERGENCY VEHICLE LIGHT DETECTOR				ELECTRIC CABLE IN CONDUIT, TRACER, NO. 14 1/C, UNLESS NOTED OTHERWISE			
RAILROAD CONTROL CABINET				CONFIRMATION BEACON				COAXIAL CABLE			
COMMUNICATIONS CABINET				HANDHOLE				VENDOR CABLE FOR CAMERA			
MASTER CONTROLLER				HEAVY DUTY HANDHOLE				COPPER INTERCONNECT CABLE, NO. 18 3 PAIR TWISTED, SHIELDED			
MASTER MASTER CONTROLLER				DOUBLE HANDHOLE				FIBER OPTIC CABLE NO. 62.5/125, MM12F			
UNINTERRUPTIBLE POWER SUPPLY				JUNCTION BOX				FIBER OPTIC CABLE NO. 62.5/125, MM12F SM12F			
SERVICE INSTALLATION, (P) POLE OR (G) GROUND MOUNT				GALVANIZED STEEL CONDUIT IN TRENCH (T) OR PUSHED (P)				FIBER OPTIC CABLE NO. 62.5/125, (NUMBER OF FIBERS & TYPE TO BE NOTED ON PLANS)			
TELEPHONE CONNECTION (P) POLE OR (G) GROUND MOUNT				TEMPORARY SPAN WIRE, TETHER WIRE, AND CABLE				GROUND ROD AT (C) CONTROLLER, (H) HANDHOLE, (P) POST, (M) MAST ARM, OR (S) SERVICE			
STEEL MAST ARM ASSEMBLY AND POLE				COMMON TRENCH			CT	CONTROLLER CABINET AND FOUNDATION TO BE REMOVED			
ALUMINUM MAST ARM ASSEMBLY AND POLE				COILABLE NONMETALLIC CONDUIT (EMPTY)			CNC	STEEL MAST ARM POLE AND FOUNDATION TO BE REMOVED			
STEEL COMBINATION MAST ARM ASSEMBLY AND POLE WITH LUMINAIRE				SYSTEM ITEM		S	S	ALUMINUM MAST ARM POLE AND FOUNDATION TO BE REMOVED			
STEEL COMBINATION MAST ARM ASSEMBLY AND POLE WITH PTZ CAMERA				INTERSECTION ITEM		I	IP	STEEL COMBINATION MAST ARM ASSEMBLY AND POLE WITH LUMINAIRE AND FOUNDATION TO BE REMOVED			
SIGNAL POST				REMOVE ITEM	R			SIGNAL POST AND FOUNDATION TO BE REMOVED			
TEMPORARY WOOD POLE (CLASS 5 OR BETTER) 45 FOOT (13.7m) MINIMUM				RELOCATE ITEM	RL			INTERSECTION & SAMPLING (SYSTEM) DETECTOR			
GUY WIRE				ABANDON ITEM	A			SAMPLING (SYSTEM) DETECTOR			
SIGNAL HEAD				12" (300mm) TRAFFIC SIGNAL SECTION				EXISTING INTERSECTION LOOP DETECTOR			
SIGNAL HEAD CONSTRUCTION STAGES (NUMBERS INDICATE THE CONSTRUCTION STAGE)				12" (300mm) RED WITH 8" (200mm) YELLOW AND GREEN TRAFFIC SIGNAL FACE				PROPOSED INTERSECTION AND SAMPLING (SYSTEM) DETECTOR			
SIGNAL HEAD WITH BACKPLATE				SIGNAL FACE				EXISTING PREFORMED INTERSECTION LOOP DETECTOR			
SIGNAL HEAD OPTICALLY PROGRAMMED				SIGNAL FACE WITH BACKPLATE, "P" INDICATES PROGRAMMED HEAD				PROPOSED INTERSECTION AND SAMPLING (SYSTEM) DETECTOR			
FLASHER INSTALLATION (S DENOTES SOLAR POWER)				12" (300mm) PEDESTRIAN SIGNAL HEAD WALK/DON'T WALK SYMBOL				PREFORMED INTERSECTION AND SAMPLING (SYSTEM) DETECTOR			
PEDESTRIAN SIGNAL HEAD				12" (300mm) PEDESTRIAN SIGNAL HEAD INTERNATIONAL SYMBOL, OUTLINED				PREFORMED SAMPLING (SYSTEM) DETECTOR			
PEDESTRIAN PUSHBUTTON DETECTOR				12" (300mm) PEDESTRIAN SIGNAL HEAD INTERNATIONAL SYMBOL, SOLID				RAILROAD SYMBOLS			
ACCESSIBLE PEDESTRIAN PUSHBUTTON DETECTOR				PEDESTRIAN SIGNAL HEAD, INTERNATIONAL SYMBOL, WITH COUNTDOWN TIMER				EXISTING		PROPOSED	
ILLUMINATED SIGN "NO LEFT TURN"				RADIO INTERCONNECT				RAILROAD CONTROL CABINET			
ILLUMINATED SIGN "NO RIGHT TURN"				RADIO REPEATER				RAILROAD CANTILEVER MAST ARM			
DETECTOR LOOP, TYPE I				DENOTES NUMBER OF CONDUCTORS, ELECTRIC CABLE NO. 14, UNLESS NOTED OTHERWISE, ALL DETECTOR LOOP CABLE TO BE SHIELDED				FLASHING SIGNAL			
PREFORMED DETECTOR LOOP				GROUND CABLE IN CONDUIT NO. 6 SOLID COPPER (GREEN)				CROSSING GATE			
MICROWAVE VEHICLE SENSOR								CROSSBUCK			
VIDEO DETECTION CAMERA											
VIDEO DETECTION ZONE											
PAN, TILT, ZOOM CAMERA											
WIRELESS DETECTOR SENSOR											
WIRELESS ACCESS POINT											

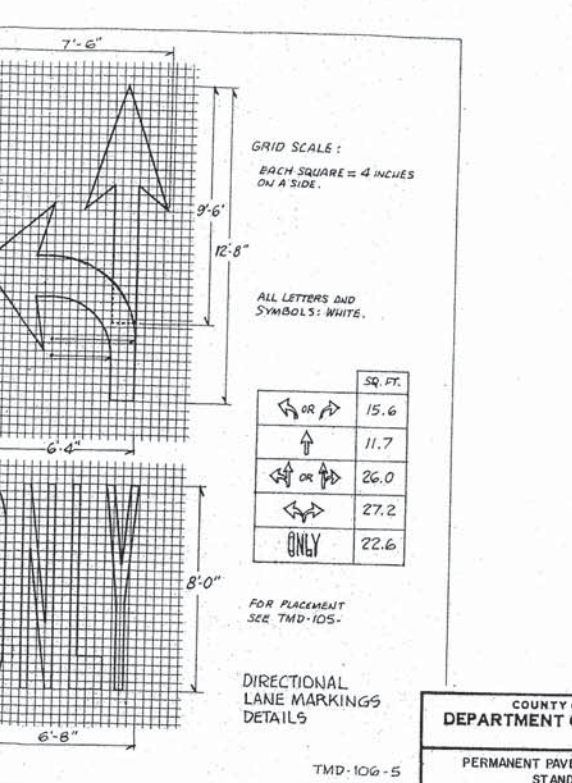
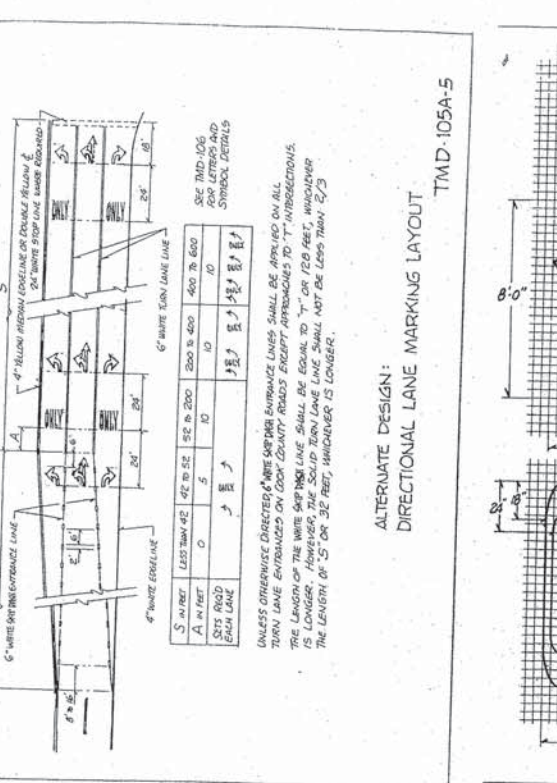
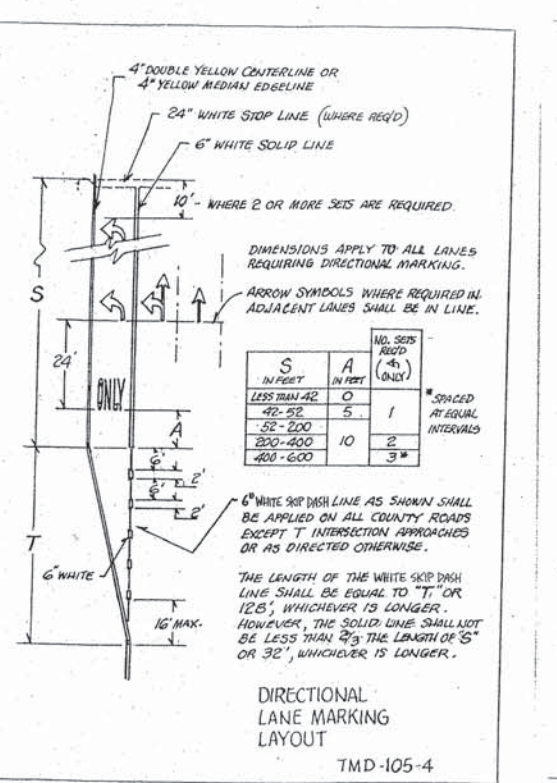
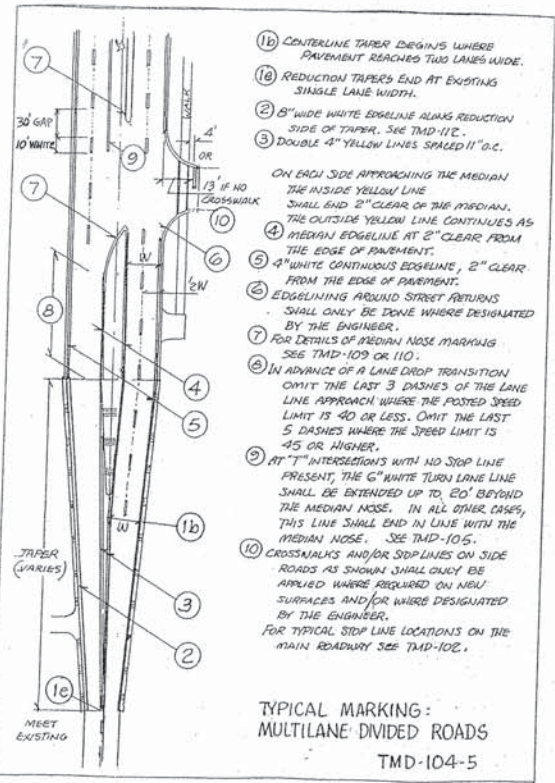
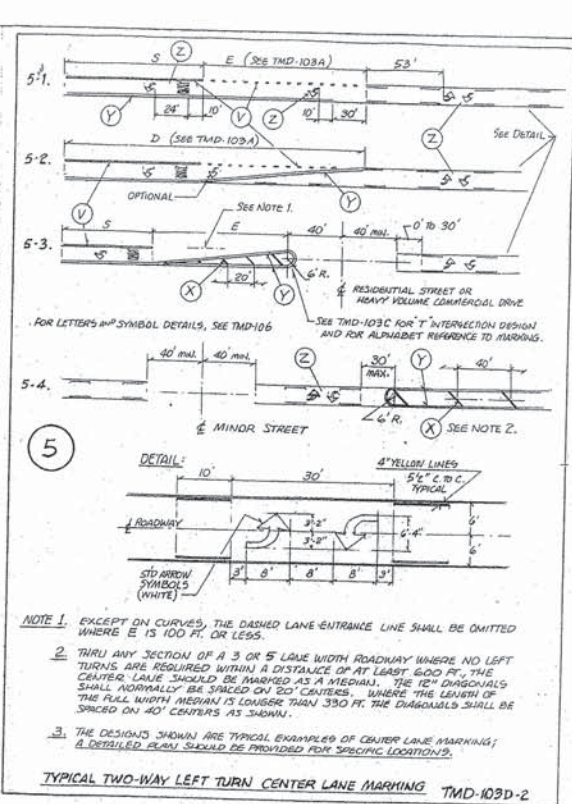
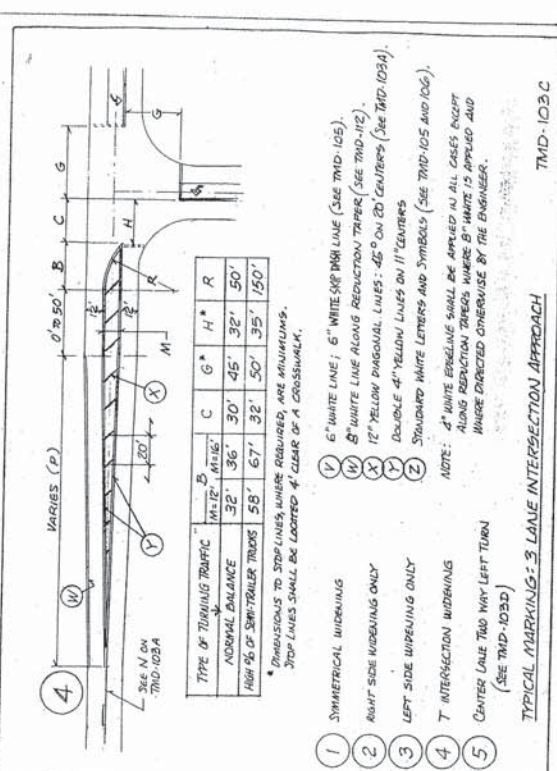
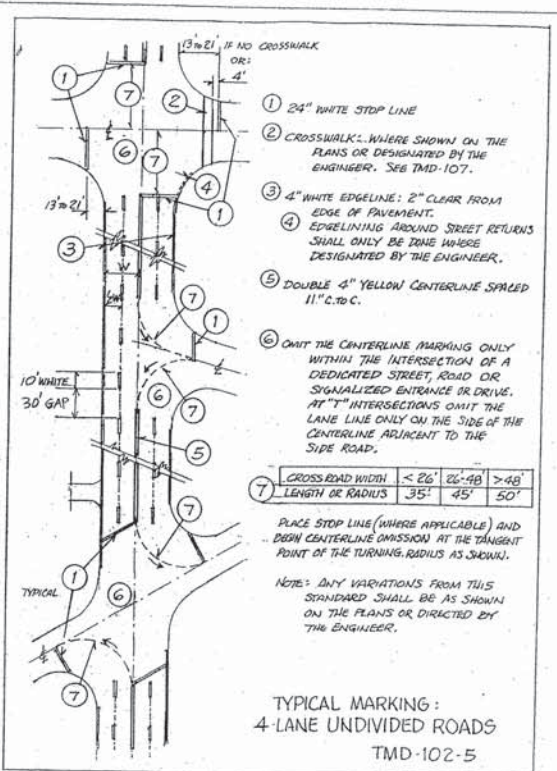
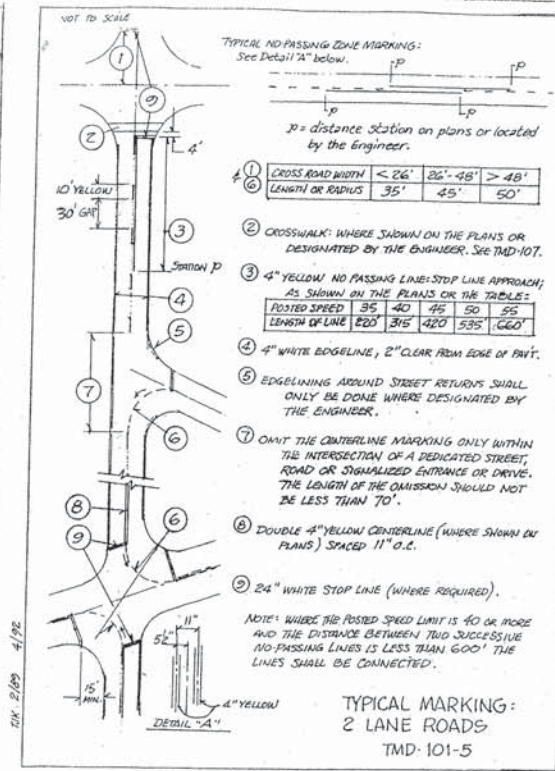

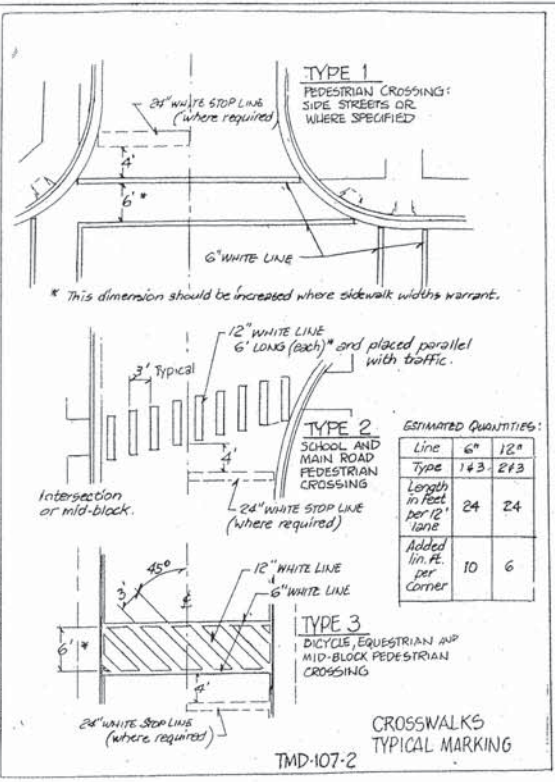

ESTIMATED QUANTITIES:

Line Type	6"	12"
Length in feet per 12" lane	24	24
Added lin. ft. per corner	10	6

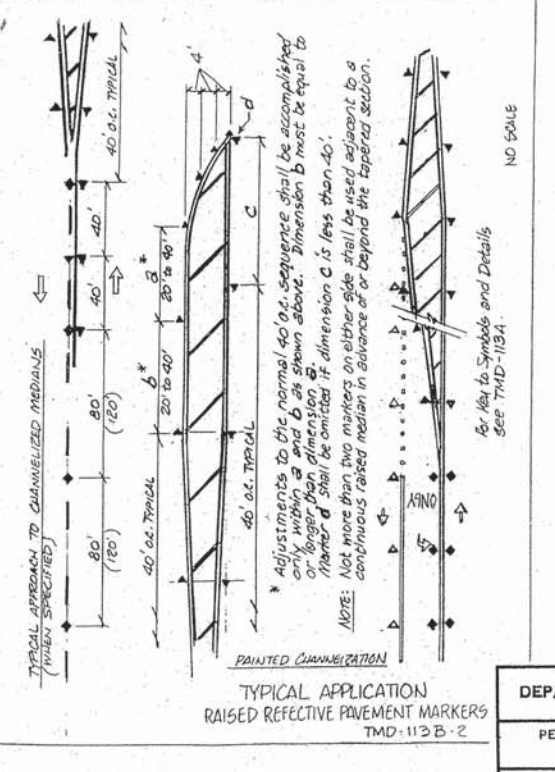
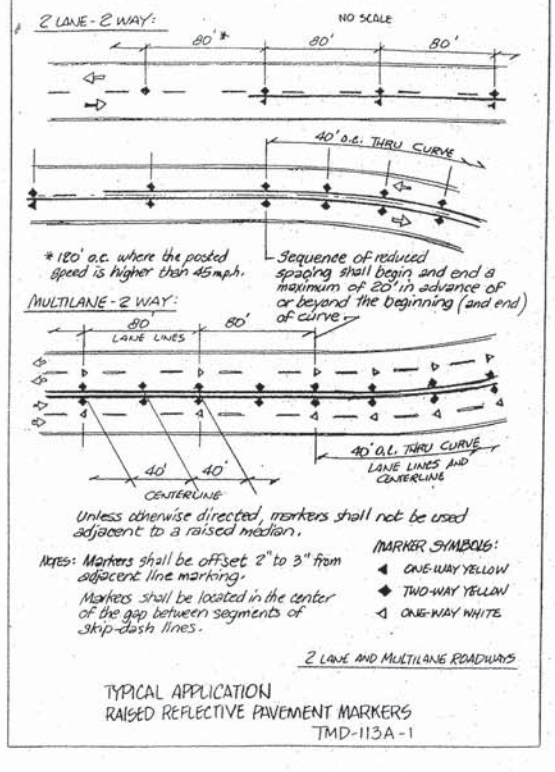
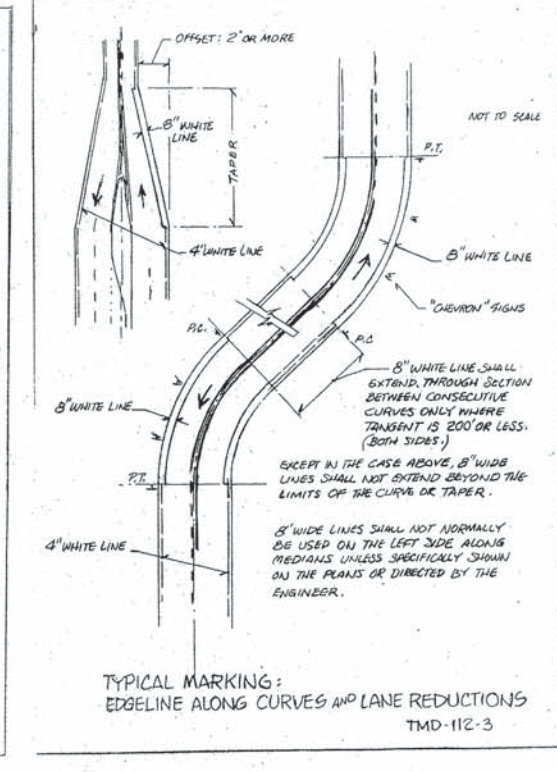
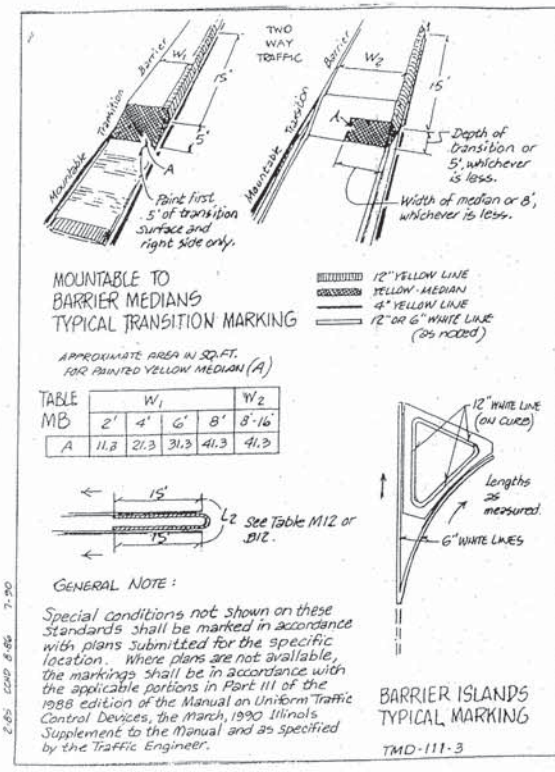
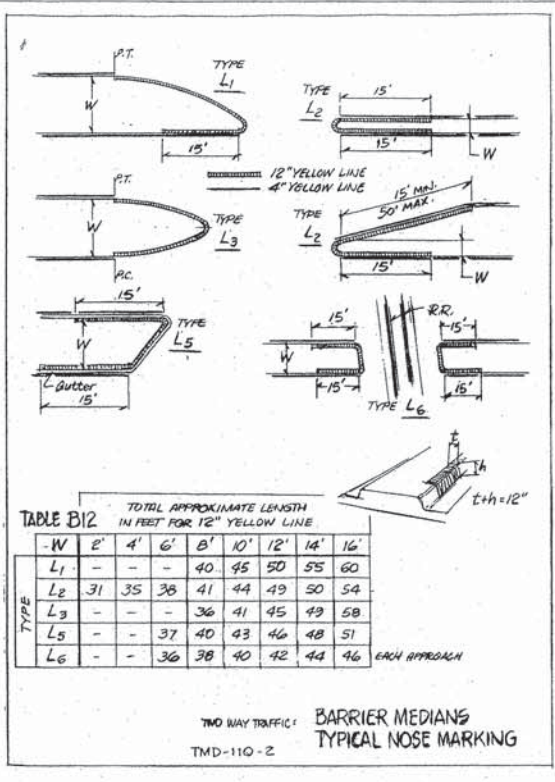
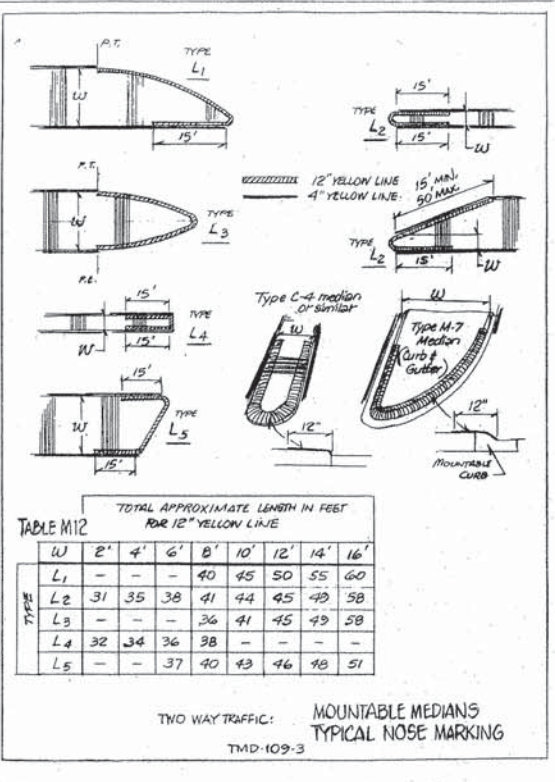
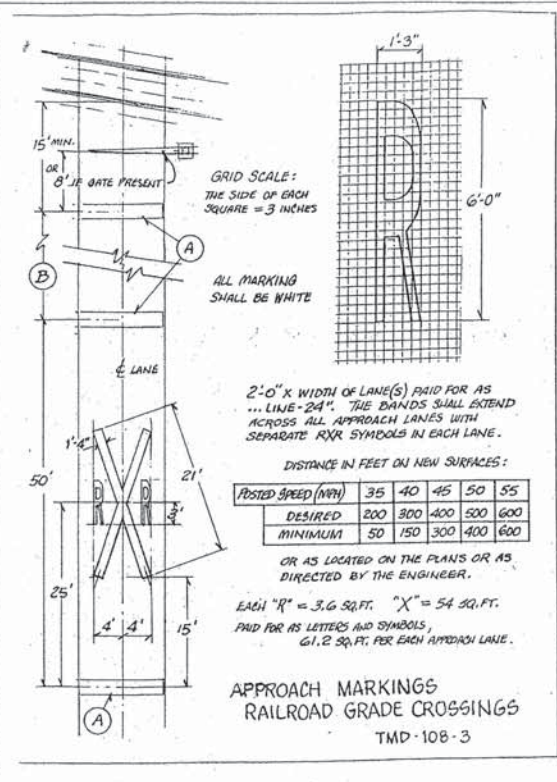

County Highway	Fiscal Year	Sheet No.	Total Sheets

Section _____

TYLIN INTERNATIONAL

DESIGN NAME	DESIGNER
CHURCH STREET AT CRAWFORD AVENUE	MBR

DESIGNED	REVISIONS
MBR	
MBR	
DBD	
DBD	
DATE	
10/18/2013	

**STATE OF ILLINOIS
DEPARTMENT OF TRANSPORTATION**

**INTERSECTION IMPROVEMENT
CHURCH STREET AT CRAWFORD AVENUE
CCHD STANDARD MARKING AND SIGNAGE DETAILS - SHEET 2 OF 4**

SCALE:	SHEET NO.	OF SHEETS	STA.	TO STA.

F.A.U. RTE.	SECTION	COUNTY	TOTAL SHEETS	SHEET NO.
1313	00-00241-00-CH	COOK	47	44

CONTRACT NO. 63734

PL02556R000CCHD STANDARD SHEET 2 OF 4

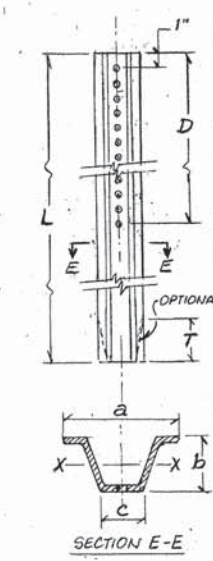

STEEL	TYPE A	TYPE B	TYPE C	
a	3 1/4"	3 3/16"	2"	MINIMUM
b	1 1/4"	1 1/2"	1 1/8"	
c	1 1/8"	1 1/2"	1"	
S _K X IN ³	0.223	0.341	-	NOMINAL
LBS/FT	2.00	3.00	1.72	
D	55 HOLES (MIN)	18 MIN.	-	
L	VARIABLE	7.0	-	
T	3"	1 1/4"	-	

ALUMINUM	TYPE A	TYPE B	
a	3 1/2"	4 5/8"	MINIMUM
b	1 5/8"	2 1/4"	
c	1 7/8"	2 3/8"	
S _K X IN ³	0.435	0.888	NOMINAL
LBS/FT	0.90	1.30	
D	55 HOLES (MIN)	-	
L	VARIABLE	-	
T	3"	-	

ALL HOLES ARE 3/8" DIA. ON 1" CENTERS.
NO SPLICES ALLOWED.
TYPE C USED FOR DELIMITERS WHEN SPECIFIED ON THE PLAN.

7 METAL POST-TYPE A, B AND C

- 1 SIGN PANEL WIDER THAN 30" AND 24" OR MORE IN DEPTH.
- 2 SIGN PANEL: VARIABLE X 18". 72" WIDE, MAXIMUM.
- 3 SIGN PANEL: WIDER THAN 42". 2 OR MORE POSTS.
- 4 SIGN PANEL: 6.5 SQ. FT. OR LARGER IN AREA (UNLESS OTHERWISE INDICATED ON THE PLAN). 2 POSTS.
- 5 SIGN PANEL: LESS THAN 6.5 SQ. FT. IN AREA AND NOT WIDER THAN 30". SINGLE POST OR OTHER SUPPORT.
- 6 SIGN PANEL: 36" MAX. DIAMETER ON SINGLE WOOD OR STEEL POST.
- 8 ROUND POST OR POLE; LIGHT STANDARD OR TRAFFIC SIGNAL.
- 9 TRAFFIC SIGNAL MAST ARM.

10 TELESCOPING STEEL SIGN SUPPORT

- 11 4"x6" WOOD SIGN SUPPORT.
- 14 3/4" WIDE X 0.030 THICK STAINLESS STEEL BAND, TYPE 201. (REGULAR BAND)
- 15 STAINLESS STEEL BUCKLE, TYPE 201 TO FIT REGULAR BAND.
- 17 1/4" X 1/4" X 1" H.W.H. #3 SELF TAPPING SIGN SCREW WITH NEOPRENE WASHER.
- 18 SIGN PANEL MOUNTING HOLES LOCATED AS PER DETAIL OR BLANK STANDARD. ALL HOLES WHERE CHANNELS ARE NOT USED SHALL BE 3/8" DIAMETER.
- 19 5/16" DIA. SQUARE HEAD BOLT, NYLON WASHER, REG. WASHER AND LOCKNUT.
- 20 5/16" DIA. HEX HEAD BOLT, NYLON WASHER, REG. WASHER AND LOCKNUT.
- 21 NON SUP WASHER.
- 24 2 1/4" X 2 1/4" BASE SECTION.
- 25 2 1/2" X 2 1/2" SLEEVE SECTION.

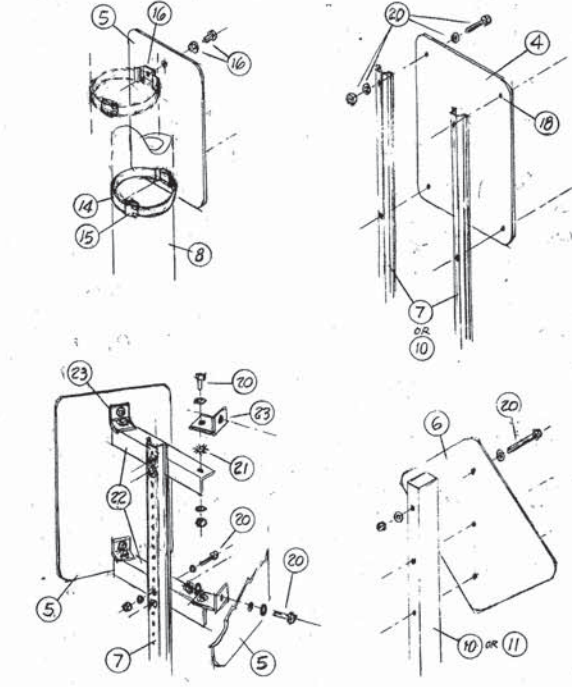

BACK TO BACK ADJUSTABLE ANGLE MOUNTING

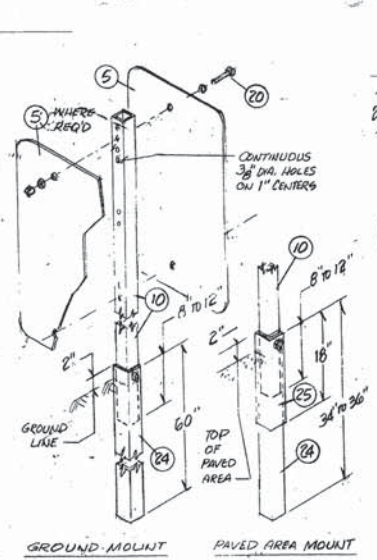

GROUND MOUNT PAVED AREA MOUNT

10 TELESCOPING STEEL SIGN SUPPORT

2" X 2" SQUARE TUBULAR SECTION

SIGN PANEL MOUNTING DETAILS

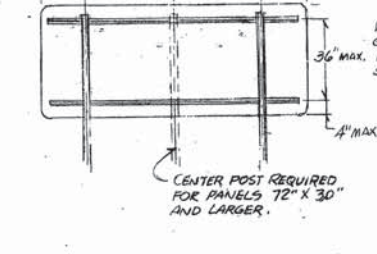

WHERE SIGN DEPTH IS GREATER THAN 44", 36" MAX. A THIRD CHANNEL SHALL BE ADDED.
CENTER POST REQUIRED FOR PANELS 72" X 30" AND LARGER.

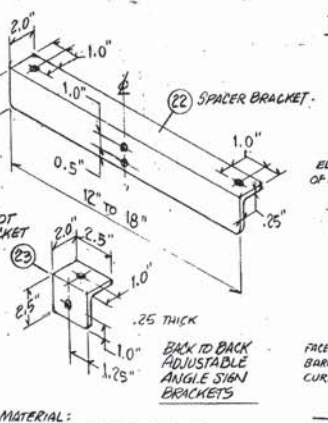

TYPICAL CLEARANCES

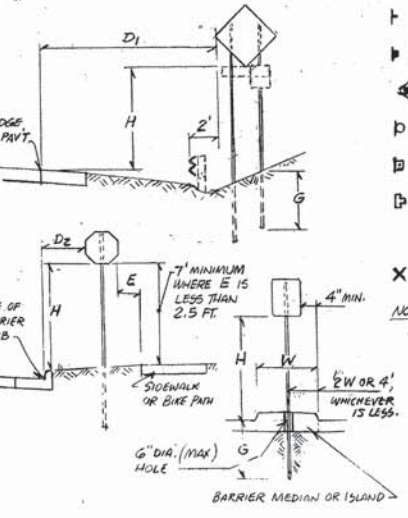

- D1 NOT LESS THAN 12 FT. (6 FT. IF ALLOWED BY THE ENGINEER IN AREAS OF LIMITED SIGHT DISTANCE OR OTHER RESTRICTIONS).
- D2 6 FT. OR MORE DESIRED. NOT LESS THAN 2 FT. WHERE 40 M.P.H. OR HIGHER IS POSTED. 1 FT. MIN. MAY BE ALLOWED IN AREAS OF 25 M.P.H. AND LOWER.
- H NORMALLY NOT LESS THAN 7 FT. MAY BE 5 FT. MIN. IN RURAL AND FOREST PRESERVE AREAS WITH NO PARKING.
- G METAL POSTS: TYPE A - 3 1/2 FT. MIN., TYPE B - 4 FT. MIN., 4"x6" WOOD - 5 FT. MIN. FOR OTHER SUPPORTS SEE THE APPLICABLE SPECIFICATIONS.

EXPLANATION OF SYMBOLS

- T F METAL POST(S)-TYPE A.
- T F METAL POST(S)-TYPE B.
- M METAL POST-TYPE B, SUPPORTING BACK TO BACK ADJUSTABLE ANGLE SIGNS.
- D SIGN MOUNTED ON LIGHT STANDARD, TRAFFIC SIGNAL POST OR MAST ARM.
- OTHER SUPPORT TYPE AS SPECIFIED ON THE PLAN.
- EXISTING SIGN ASSEMBLY TO REMAIN IN PLACE, BE RE-ERECTED OR RELOCATED AS DIRECTED BY THE ENGINEER AND IN ACCORDANCE WITH ARTICLE 107.22 OF THE STANDARD SPECIFICATIONS FOR ROAD AND BRIDGE CONSTRUCTION.
- EXISTING SIGN ASSEMBLY BEYOND THE CONSTRUCTION LIMITS TO BE REMOVED.

NOTE: EXCEPT FOR SIGNS SHOWN IN 1) AND/OR OTHERWISE SPECIFIED, ALL EXISTING TRAFFIC SIGN ASSEMBLIES WITHIN THE CONSTRUCTION LIMITS SHALL BE REMOVED. SEE THE SPECIAL PROVISION.

GENERAL NOTES FOR SIGNING

- 1 THE DESIGN OF ALL STANDARD TRAFFIC SIGNS SHALL CONFORM WITH THE STATE OF ILLINOIS MANUAL ON UNIFORM TRAFFIC CONTROL DEVICES FOR STREETS AND HIGHWAYS. (M.U.T.C.D.). SPECIAL AND VARIABLE MESSAGE SIGNS SHALL CONFORM WITH THE DETAILS AS SHOWN ON THE PLANS.
- 2 ALL SIGNS, SUPPORTS, MATERIAL AND RELATED WORK SHALL BE IN ACCORDANCE WITH THE APPLICABLE SECTIONS OF THE ILLINOIS DEPARTMENT OF TRANSPORTATION STANDARD SPECIFICATIONS FOR TRAFFIC CONTROL ITEMS, THE STANDARD SPECIFICATIONS FOR ROAD AND BRIDGE CONSTRUCTION, THE SPECIAL PROVISIONS AND THE PLANS.
- 3 SIGN SUPPORT LENGTHS SHALL BE DETERMINED AT THE SITE IN ACCORDANCE WITH THE CLEARANCES AND OFFSET LOCATIONS SHOWN.
- 4 IT SHALL BE THE RESPONSIBILITY OF THE CONTRACTOR TO DETERMINE THE LOCATION OF ANY UNDERGROUND ELECTRIC CABLES, UTILITY LINES OR DRAINAGE STRUCTURES IN THE VICINITY BEFORE BEGINNING WORK. AN ASSEMBLY SHALL BE RELOCATED FROM THE STATION SHOWN ON THE PLAN WHERE NECESSARY TO AVOID DAMAGING ANY UNDERGROUND INSTALLATION.
- 5 WHERE METAL POSTS ARE SPECIFIED, 2 POSTS SHALL SUPPORT A SIGN PANEL ASSEMBLY HAVING A TOTAL AREA OF 6.5 SQ. FT. OR MORE. A 6-FT. X 2.5 FT. AND LARGER SIGN PANEL ASSEMBLY SHALL BE SUPPORTED WITH 3 POSTS.
- 6 THE TRAFFIC OPERATIONS DIVISION OF THE COOK COUNTY HIGHWAY DEPARTMENT SHALL BE NOTIFIED TEN (10) DAYS PRIOR TO THE ESTIMATED DATE OF THE INSTALLATION OF THE PERMANENT TRAFFIC CONTROL DEVICES.

MOUNTING ASSEMBLY NOTES

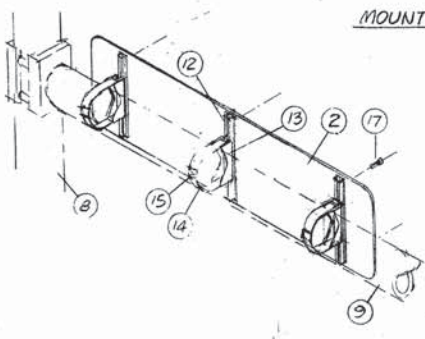

EXCEPT FOR NYLON AND NEOPRENE WASHERS WHERE INDICATED, ALL MOUNTING HARDWARE SHALL BE ZINC OR CADMIUM PLATED STEEL, ALUMINUM OR STAINLESS STEEL. ALL BOLTS AND NUTS SHALL HAVE NATIONAL COURSE (UNC) THREAD.
SUPPORTING CHANNELS SHALL BE USED ON RECTANGULAR PANELS WIDER THAN 36" ON A SINGLE SUPPORT AND ON PANELS WIDER THAN 48" WHEN MOUNTED ON MORE THAN ONE POST, AND ON DIAMOND SHAPED 48" X 48" PANELS. CHANNELS MAY BE USED TO MOUNT 2 TYPE 1 ADJACENT SIGN PANELS.
MOUNTING METHODS AND MATERIAL OTHER THAN THAT SHOWN ARE ACCEPTABLE UPON THE APPROVAL OF THE ENGINEER AND WHERE COMPLETELY INTERCHANGEABLE WITH EXISTING INSTALLATIONS ON COUNTY AND STATE ROADWAYS.

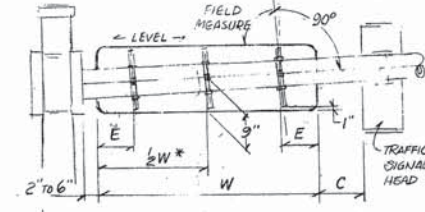

INCHES:

W	42"	48"	54"	60"	66"	72"
E	8	10	11	10	11	12
C	.75 W OR MORE DESIRED; 1'-0" MINIMUM					

*NO CENTER MOUNTING REQ'D

TRAFFIC SIGN MOUNTING DETAILS
TRAFFIC DIVISION
COOK COUNTY HIGHWAY DEPARTMENT
STANDARD 304-2

REV. 3-21-91
DRAWN BY: JJK 12-15-89
APPROVED: 12-15-89: Charles D. Tavel, TRAFFIC ENGINEER

COUNTY	FISCAL YEAR	SHEET NO.	TOTAL SHEETS
X	X	X	X
SECTION: XX-XXXX-XX-XX			

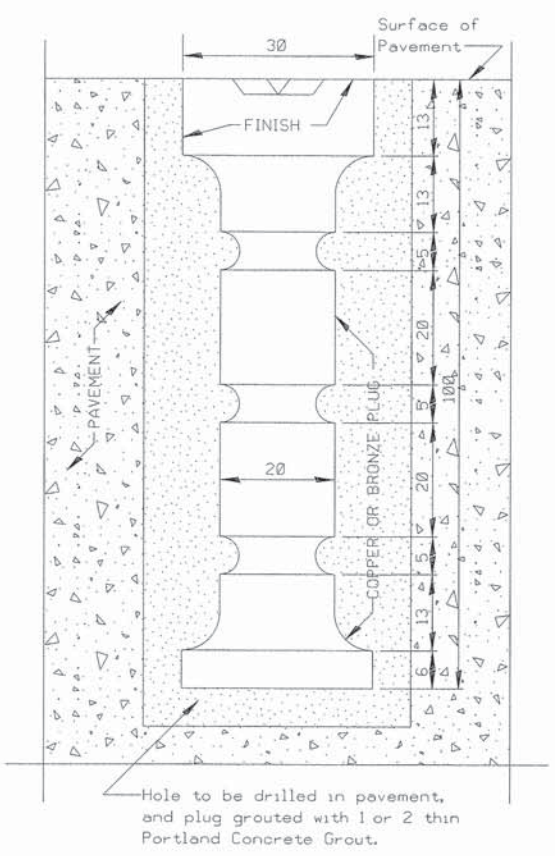

DETAIL FOR PLACING MONUMENT IN PAVEMENT

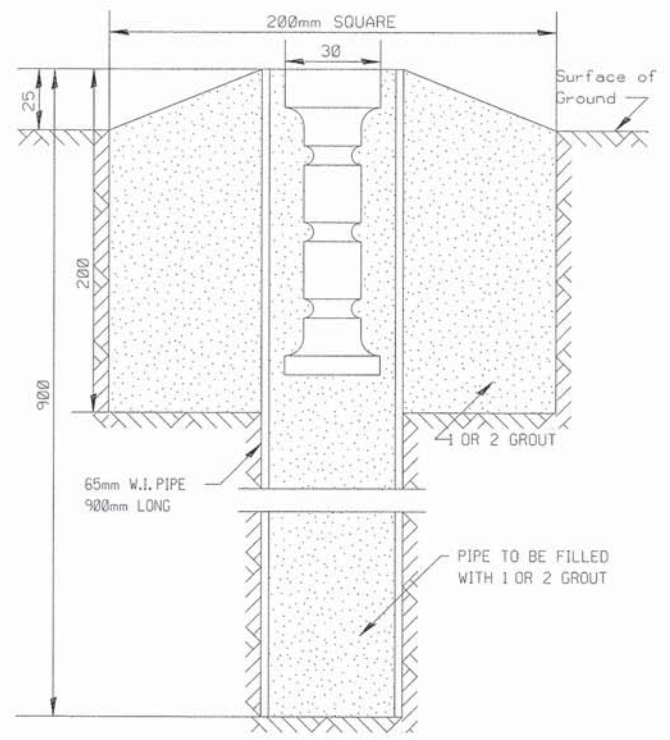

DETAIL FOR PLACING MONUMENT WHEN LOCATED OUTSIDE OF PAVEMENT



ALL DIMENSIONS ARE IN MILLIMETERS UNLESS OTHERWISE SHOWN.

NOT TO SCALE

COUNTY OF COOK DEPARTMENT OF HIGHWAYS			
DETAIL OF SURVEY MONUMENT			
COMPUTED	K.L.P.		
DRAWN	G.D.S.		
CHECKS	K.L.P.		

TYLIN INTERNATIONAL	USER NAME - BUSP111	DESIGNED - MBR	REVISED -
	PLANT SCALE - 1:40000	DRAWN -	REVISED -
	PRINT DATE - 10/17/2013	CHECKED - DBD	REVISED -
		DATE - 10/18/2013	REVISED -

STATE OF ILLINOIS
DEPARTMENT OF TRANSPORTATION

INTERSECTION IMPROVEMENT
CHURCH STREET AT CRAWFORD AVENUE
CCHD SURVEY MONUMENT DETAIL

F.A.U. RTE.	SECTION	COUNTY	TOTAL SHEETS	SHEET NO.
1313	00-00241-00-CH	COOK	47	47
FED. ROAD DIST. NO. [ILLINOIS] FED. AID PROJECT			CONTRACT NO. 63734	

FIG 02556 (Rev. 06/00) CCHD STANDARD SHEET 5.dgn