

**PLAN**

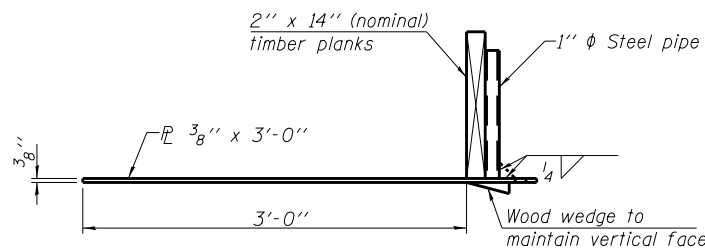

**SECTION A-A**

**TEMPORARY GEOTEXTILE FORM BRACE DETAIL**

Note:

This is a suggested detail, the Contractor is responsible for the design of the form brace system to be used.

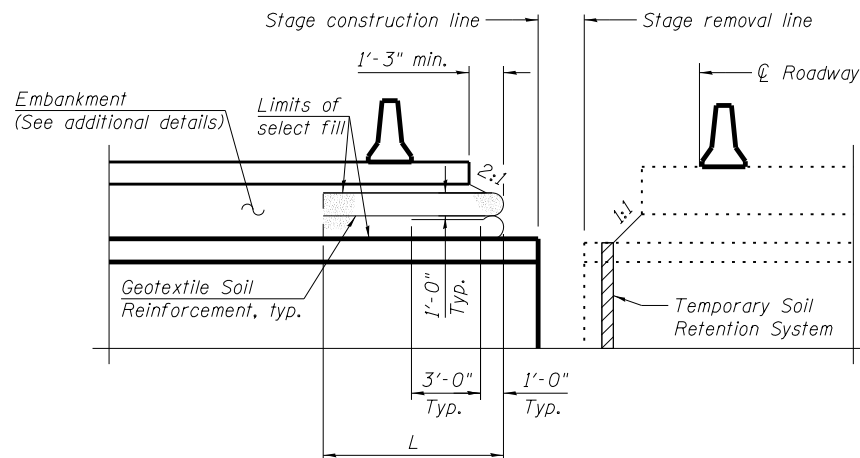

**TEMPORARY GEOTEXTILE WALL TYPICAL SECTION**

Soil Reinforcement Schedule				
Station	Soil reinf. type	Layer (numbered from bottom)	Length L (ft)	
1401+37	Geotextile	1-7	7'-0"	Wrapped Face
1415+50	Geotextile	1-8	8'-0"	Wrapped Face

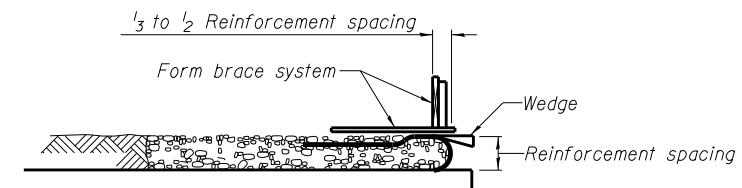

1. Place form brace system on completed reinforcement level; back from the finished fabric face a distance of  $\frac{1}{3}$  to  $\frac{1}{2}$  the geotextile reinforcement spacing.

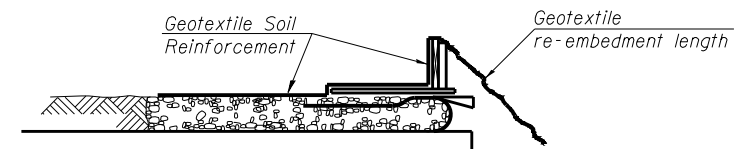

2. Position fabric so that the required geotextile re-embedment length extends over the top of the form brace and the design reinforcement width is placed with no slack against the previous level.

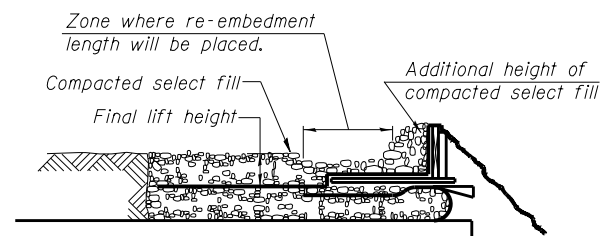

3. Compact select fill material in lifts to final lift height, create ( $\pm 3''$ ) depression in zone where re-embedment length will be located and place additional height of compacted select fill against form brace.

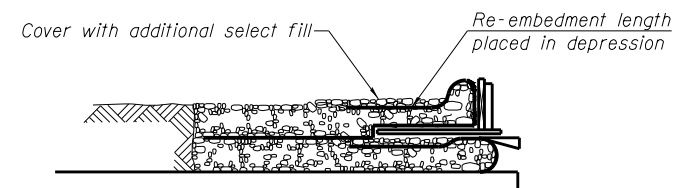

4. Fold geotextile re-embedment length back over form brace into zone where depression was made in select fill and place additional select fill ( $\pm 3''$ ) to embed geotextile and bring to final lift height.

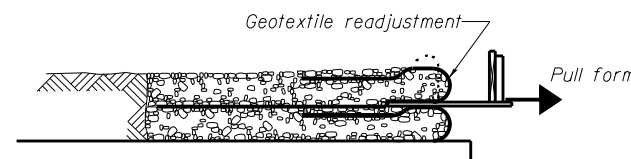

5. Pull form brace outward allowing geotextile face to slightly readjust to form tight round face level with plan reinforcement spacing.

**TEMPORARY GEOTEXTILE WALL CONSTRUCTION SEQUENCE**

Note:

The geotextile soil reinforcement shall have a minimum allowable tensile strength (T min.) of 28 lb./in. as determined by the procedure described in the Special Provision. The computations supporting the determination of (T min.) shall be submitted to the engineer for approval.