

ELEVATION AT ABUT.

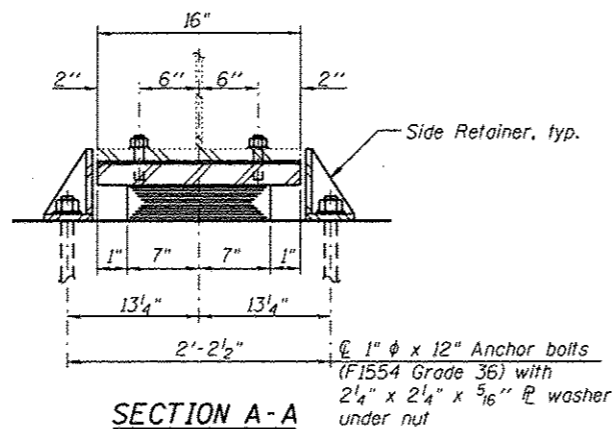

SECTION A-A

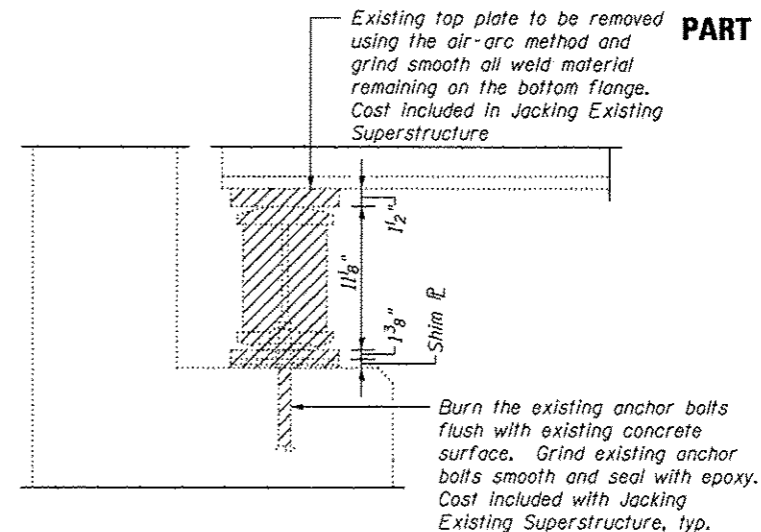

EXISTING ABUTMENT BEARING REMOVAL

TYPE I ELASTOMERIC EXP. BRG.

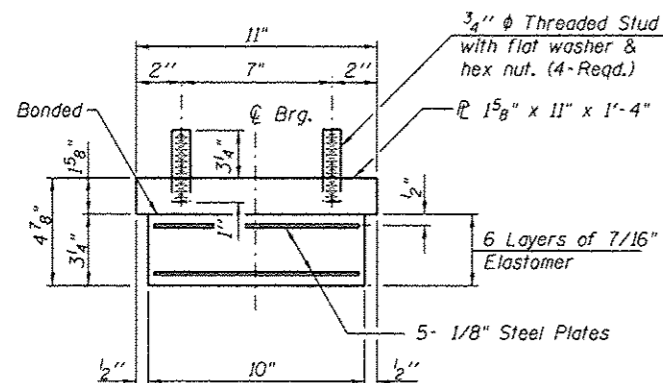

BEARING ASSEMBLY

Notes:

Anchor bolts shall be ASTM F1554 all-thread (or an Engineer-approved alternate material) of the grade(s) and diameter(s) specified. The corresponding specified grade of AASHTO M314 anchor bolts may be used in lieu of ASTM F1554.

Anchor bolts for side retainers may be cast in place or installed in holes drilled before or after members are in place.

Drilled and set anchor bolts shall be installed according to Article 521.06 of the Standard Specifications.

Side retainers and other steel members required for the elastomeric bearing assembly shall be included in the cost of Elastomeric Bearing Assembly, Type I.

Two 5/8 inch adjusting shims shall be provided for each bearing in addition to all other plates or shims and placed as needed and as shown on bearing details.

Note:

Shim plates shall not be placed under Bearing Assembly.

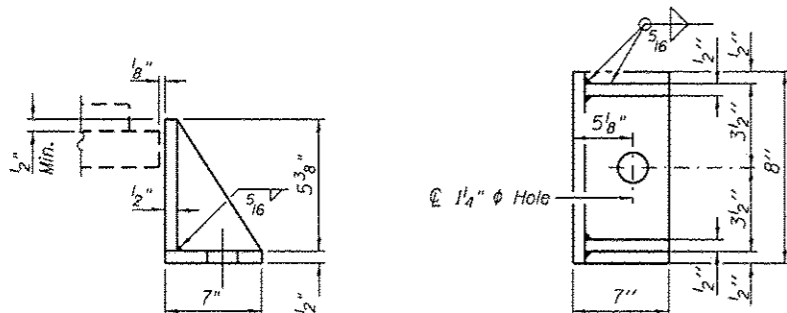

SIDE RETAINER

Equivalent rolled angle with stiffeners will be allowed in lieu of welded plates.

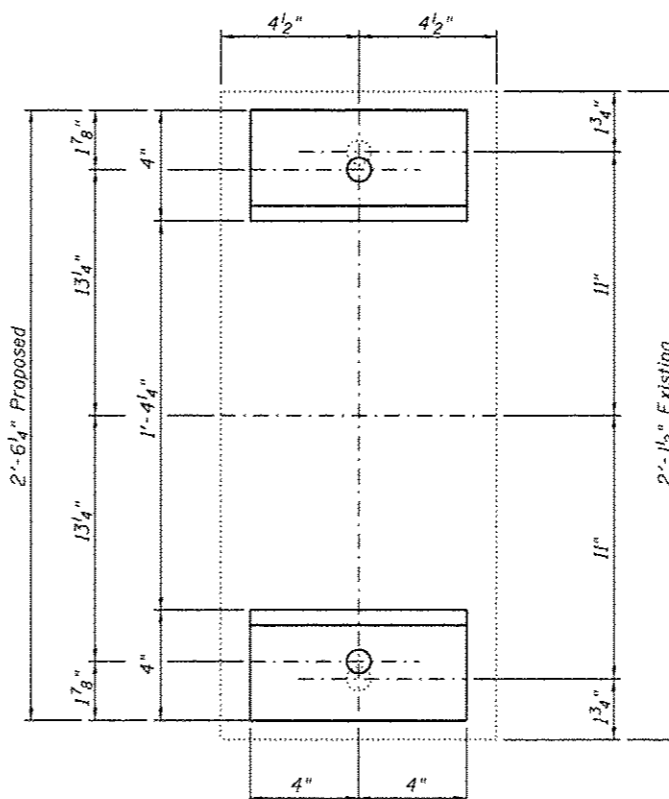

ANCHOR BOLT LAYOUT

Note: Shown for visual only, new bearing seats will prevent interference with existing anchor bolts.

JACK AND REMOVE EXISTING BEARING PROCEDURE

(North and South Abutments)

1. The Contractor shall submit for approval by the Engineer, plans for jacking existing beams and installing new bearings prior to commencing any related work.
2. Jacking and removing existing bearings shall be done after existing concrete deck is removed and prior to pouring the concrete deck.
3. Prior to ordering any material, the Contractor shall verify shim plate thickness required at each bearing so that total height of new bearing and fill matches height of existing bearing and shim.
4. There shall be at least one jack per bearing, and the Jack shall be placed close to the bearings.
5. For limitations on lift amounts, see Special Provisions.
6. The new bearing shall be in place and the jacks shall be lowered before the new concrete deck is poured. Existing diaphragms to be unbolted due to differential deflections during stage construction.
7. Jacking against diaphragms is prohibited.
8. Cross frames are to be removed at the stage line prior to jacking and re-installed prior to the final deck pour.
9. Re-bolt existing diaphragms after completion of Stage III deck pour.

Prior to ordering any material, the Contractor shall verify in the field all bearing height and shim thickness dimensions.

BEAM REACTIONS

(Steel only)

R _D	(k)	13.2
----------------	-----	------

Min. Jack Capacity = 10 Ton (Without Deck)

BILL OF MATERIAL

Item	Unit	Total
Elastomeric Bearing Assembly Type I	Each	18
Anchor Bolts, 1"	Each	36
Jacking Existing Superstructure	L. Sum	1