

STA 562+69 TO STA 568+70

- EXISTING RAISED CONCRETE MEDIAN SHIFTS RIGHT TO LEFT OF CENTERLINE STA. 562+69 TO STA. 564+11
- VARIABLE, 0.0' TO 8.5' @ : STA. 564+11 TO 565+61.20
8.5' @ : STA. 565+61.20 TO STA. 567+58.75

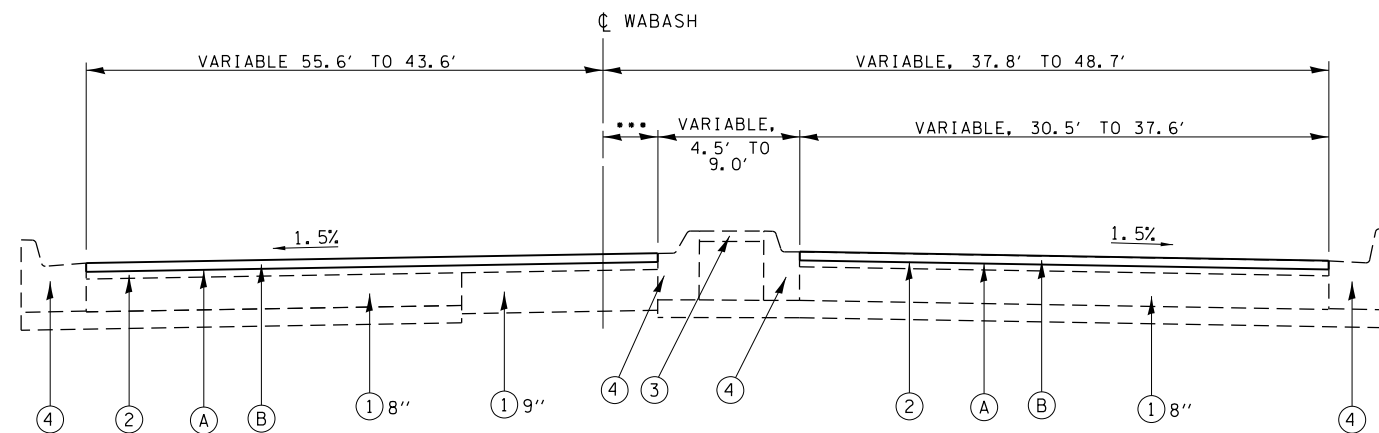

STA 568+70 TO STA 572+99

- 4.4' @ : STA. 569+43.90 TO 572+35.04
VARIABLE, 4.4' TO 0.0' @ : STA. 572+35.04 TO STA. 572+98.85

NOTE:
SEE STRIPING DETAIL FOR LAYOUT OF PAVEMENT MARKINGS FOR THRU LANES, TURNING LANES, ISLANDS, ETC.

EXISTING LEGEND

- ① PCC PAVEMENT
- ② HMA SURFACE, 3 1/2" MINIMUM & VARIABLE
- ③ CONCRETE MEDIAN
- ④ CURB & GUTTER

PROPOSED LEGEND

- Ⓐ HOT-MIX ASPHALT SURFACE REMOVAL, VARIABLE DEPTH (1 1/2" @ Ⓞ)
- Ⓑ POLYMERIZED HOT-MIX ASPHALT SURFACE COURSE, MIX "E", N70, 1 1/2 "
- Ⓒ SUB-BASE GRANULAR MATERIAL, TY B (DEPTH = 4")
- Ⓓ BASE COURSE (OPTION), (10 1/2" DEPTH)
- Ⓔ ITEM OMITTED
- Ⓕ PAVEMENT MARKING 5"
- Ⓖ COMBINATION CONCRETE CURB & GUTTER, TYP B-6.24
- Ⓗ CONCRETE MEDIAN SURFACE, 4"

FILE NAME =	USER NAME = sparksgw	DESIGNED - RTS	REVISED -	STATE OF ILLINOIS DEPARTMENT OF TRANSPORTATION	TYPICAL CROSS SECTIONS			F.A.P. RTE.	SECTION	COUNTY	TOTAL SHEETS	SHEET NO.
ct:\pw\work\p\dot\sparksgw\10296742\07229-sh1-typical.dgn		DRAWN - RTS	REVISED -		664	.	SANGAMON	126	32			
Default	PLOT SCALE = 100.0000' / in.	CHECKED -	REVISED -		SCALE: SHEET 8 OF 11 SHEETS STA. TO STA.			CONTRACT NO. 72F29				
	PLOT DATE = Nov-08-2013 12:08:21PM	DATE - 10-11-2013	REVISED -		ILLINOIS FED. AID PROJECT (GORS-15,TS-9,(2)RS-9,TS-2							