

C SUPERELEVATED SECTION WITH RAMP

LT STA 1497+91.39 TO STA 1509+77.91
 RT STA 1504+18.14 TO STA 1511+05.58

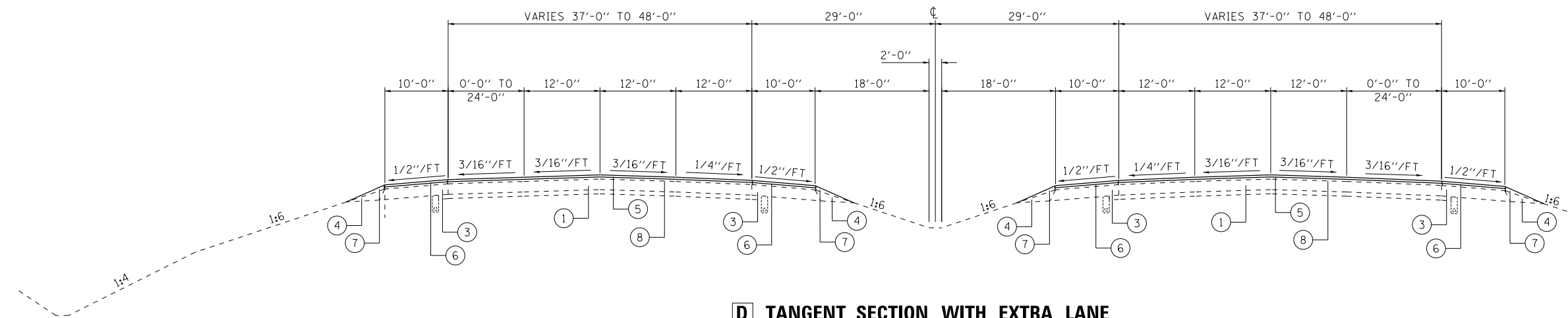

D TANGENT SECTION WITH EXTRA LANE

RT STA 1522+79.78 TO STA 1531+28.00
 LT STA 1523+61.57 TO STA 1530+49.09

- ① EXISTING PCC PAVEMENT
- ② EXISTING BITUMINOUS PAVEMENT
- ③ EXISTING BITUMINOUS SHOULDER
- ④ EXISTING AGGREGATE SHOULDERS
- ⑤ POLYMERIZED HOT-MIX ASPHALT SURFACE COURSE, STONE MATRIX ASPHALT, N80 - (2 - 2" LIFTS)
- ⑥ HOT-MIX ASPHALT SHOULDERS, (2 - 2" LIFTS)
- ⑦ AGGREGATE WEDGE SHOULDER, TYPE B - (4" TO 0")
- ⑧ BITUMINOUS MATERIALS (PRIME COAT) AND AGGREGATE (PRIME COAT)
- ⑨ HMA/PCC SURFACE REMOVAL (SEE SCHEDULE FOR THICKNESS AND LOCATIONS)
- ⑩ PIPE UNDERDRAINS, 4"

EXISTING PAVEMENT AND SHOULDER THICKNESSES				
RIGHT (NORTHBOUND)			PAVEMENT	SHOULDER
1390+00.00	TO	1531+28.00	10" CRPCCP	10" BITUMINOUS
1531+28.00	TO	1556+00.00	10" CRPCCP	10" BITUMINOUS
4.25" OVERLAY				
1556+00.00	TO	1599+00.00	10" CRPCCP	10" BITUMINOUS
0.5" MILL AND 3.75" OVERLAY				
1599+00.00	TO	1627+34.90	16.5" BITUMINOUS	8" BITUMINOUS
LEFT (SOUTHBOUND)			PAVEMENT	SHOULDER
1390+00.00	TO	1531+28.00	10" CRPCCP	10" BITUMINOUS
1531+28.00	TO	1557+00.00	10" CRPCCP	10" BITUMINOUS
4.25" OVERLAY				
1557+00.00	TO	1614+52.00	10" CRPCCP	10" BITUMINOUS
0.5" MILL AND 3.75" OVERLAY				
1614+52.00	TO	1623+00.00	10" CRPCCP	10" BITUMINOUS
1623+00.00	TO	1627+54.93	16.5" BITUMINOUS	8" BITUMINOUS

FROM EXISTING PLANS, ACTUAL FIELD CONDITIONS MAY VARY.

SUPERELEVATION TABLE			
1385+50.00	TO	1388+00.00	TRANSITION
1388+00.00	TO	1400+50.00	4.4% SUPER
1400+50.00	TO	1403+00.00	TRANSITION
1439+00.00	TO	1441+50.00	TRANSITION
1441+50.00	TO	1472+50.00	5.2% SUPER
1472+50.00	TO	1475+00.00	TRANSITION
1497+50.00	TO	1500+00.00	TRANSITION
1500+00.00	TO	1512+00.00	5.2% SUPER
1512+00.00	TO	1514+50.00	TRANSITION
1566+34.35	TO	1567+76.91	TRANSITION
1567+76.91	TO	1578+39.69	4.4% SUPER
1578+39.69	TO	1579+82.25	TRANSITION

FROM EXISTING PLANS, ACTUAL FIELD CONDITIONS MAY VARY. OVERLAY SHALL BE PLACED AT THICKNESS SHOWN ON TYPICAL SECTIONS.