

PLAN VIEW
APPROACH SLAB OR BRIDGE APPROACH SHOULDER
 (STANDARD 609001 or 609006)

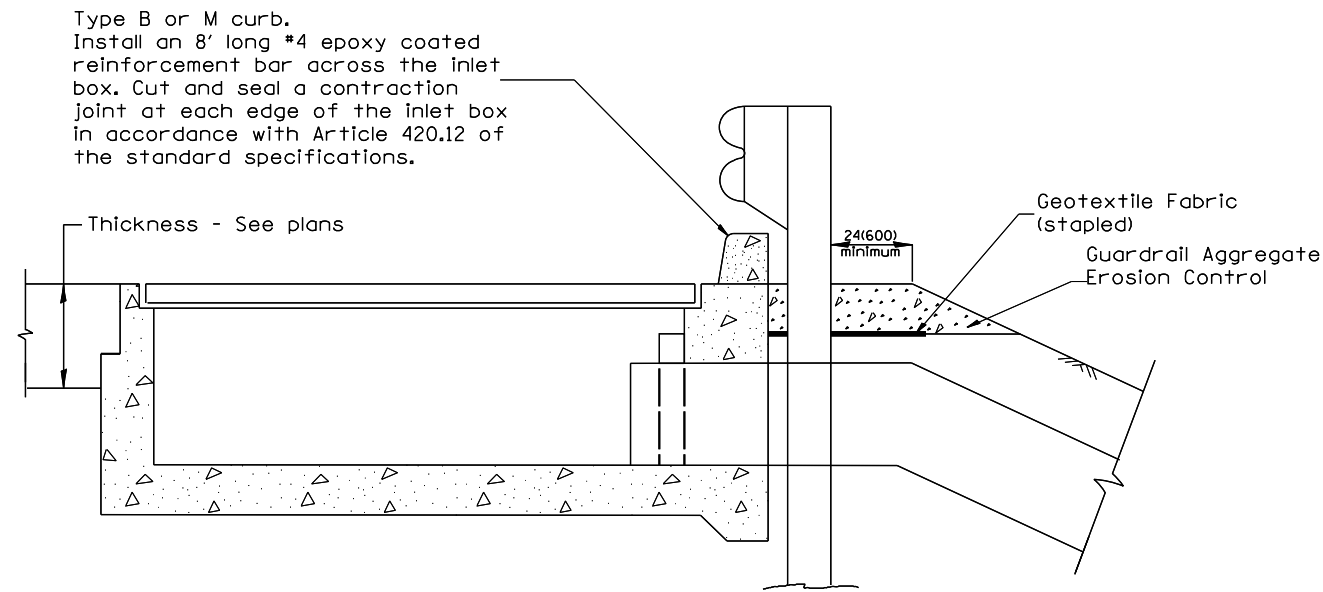

TYPICAL SECTION AT INLETS
TYPE E & F (STANDARD 610001)

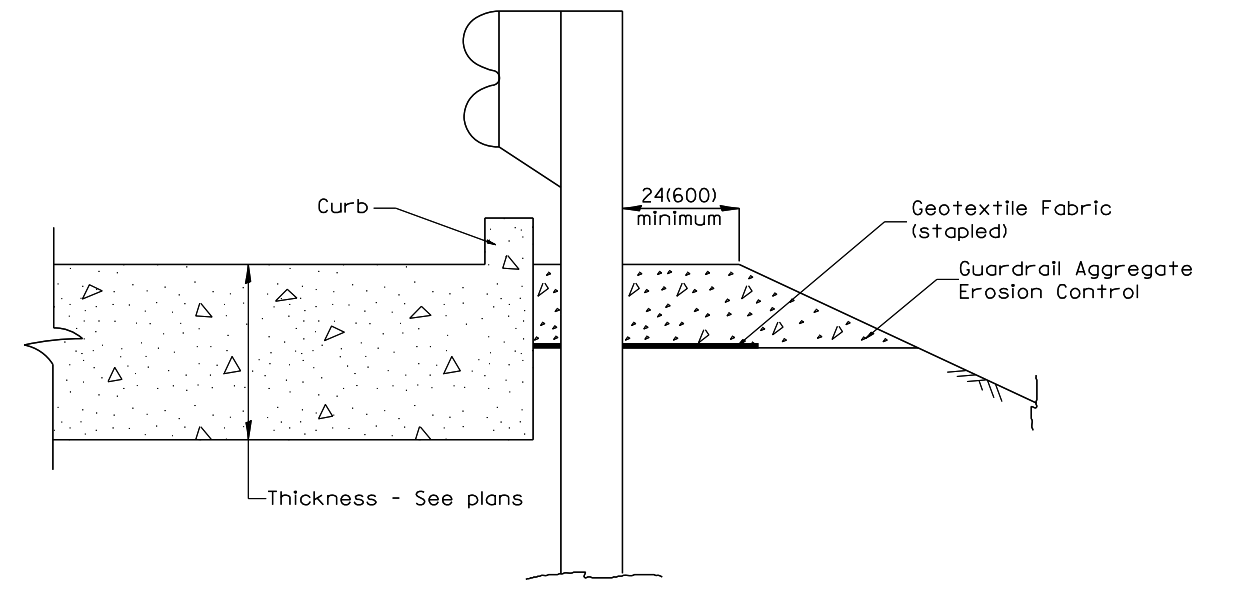

SECTION A-A
TYPICAL SECTION WITH BRIDGE APPROACH CURB

All dimensions are in inches (millimeters) unless otherwise noted.

FILE NAME =	USER NAME = crespole	DESIGNED -	REVISED -	STATE OF ILLINOIS DEPARTMENT OF TRANSPORTATION	GUARDRAIL EROSION CONTROL TREATMENTS	F.A. RTE.	SECTION	COUNTY	TOTAL SHEETS	SHEET NO.
ei:\pwork\widot\crespole\d0330150\0488792-sht-standards.dgn		DRAWN -	REVISED -			1380	7W-1, RS-3	PEORIA	617	363
Default	PLOT SCALE = 100.0000' / in.	CHECKED -	REVISED -			SHT. 2 OF 2		CONTRACT NO. 88792		
	PLOT DATE = 8/15/2013	DATE -	REVISED -			NOT TO SCALE	SHEET OF SHEETS	STA.	CADD STANDARD 630101-D4	FED. ROAD DIST. NO.