

Original Report Date: Jan. 15, 2019 Proposed SN: 019-0050 Route: FAP 553(IL 72)
 Revised Date: June 18, 2019 Existing SN: 019-0021 Section: (125BR-1)ES
 Geotechnical Engineer: IDOT District 3: Mike Short County: DeKalb
 Structural Engineer: Chamlin & Associates Inc.: James K Clinard Contract: 66H52

Indicate the proposed structure type, substructure types, and foundation locations (attach plan and elevation drawing): The proposed structure is a single span bridge and will provide a clear width of 36.375 feet face to face of parapet, with a proposed back to back of abutments distance of 76.5 feet. PCC I-beams and integral abutments will be used. A location map and the draft TSL drawing are attached.

Discuss the existing boring data, existing plans foundation information, new subsurface exploration and need for any additional exploration to be provided with SGR Technical Memo (attach all data and subsurface profile plot): Two current structure borings are provided on the attachments. Both borings show similar soil stratigraphy composed of stiff to very stiff clay loam fill with potential cobbles/boulders layer beneath this layer. Auger refusal was at 27 feet at the east abutment and 21 feet at the west abutment.

Provide the location and maximum height of any new soil fill or magnitude of footing bearing pressure. Estimate the amount and time of the expected settlement. Indicate if further testing, analysis, and/or ground improvement/treatment is necessary: The proposed profile is expected to increase by a maximum of 2 feet. Site visit was conducted on November 20, 2018 and showed no indication of significant settlement. Therefore, further investigation is not warranted.

Identify any new cuts or fill slope angles and heights. Estimate the factor of safety against slope failure. Indicate if further testing, analysis or ground improvement/treatment is necessary: Due to the minimal change in profile grade and additional fill, slope stability analysis is not required. In addition, a field inspection of the existing embankment slopes showed no stability problems.

Indicate at each substructure, the 100-year and 200-year total scour depths in the Hydraulics report, the non-granular scour depth reduction, the proposed ground surface, and the recommended foundation design scour elevations: Since the proposed structure is a single span bridge with integral abutments, the design scour elevations are set at the bottom of the abutments.

Event / Limit State	Design Scour Elevations (ft.)		Item 113
	West Abutment	East Abutment	
Q100	764.68	762.32	8
Q200	764.68	762.32	
Design	764.68	762.32	
Check	764.68	762.32	

Determining the seismic soil site class, the seismic performance zone, the 0.2 and 1.0 second design spectral accelerations and indicate if that the soils are liquefiable: The Seismic Site Class Definition is C. The corresponding 0.2 (SDS) and 1.0 (SD1) second horizontal response spectral acceleration coefficients is 0.107g and 0.058g, respectively. The Seismic Performance Zone (SPZ) is 1; therefore, liquefaction analysis not warranted.

Confirm feasibility of the proposed foundation or wall type and provide design parameters. Attach a pile design table indicating feasible pile types, various nominal required bearings, factored resistances available and corresponding estimated lengths at locations where piles will be used. Provide factored bearing resistance and unit sliding resistance at various elevations and confirm no ground improvement/treatment is necessary where spread footings are proposed. Estimated top of rock elevations as well as preliminary factored unit side and tip resistance values shall be indicated when drilled shafts are proposed:

H-piles are the District's preferred foundation type because the piles will be driven to the top of rock and the potential for cobbles, boulders, and conflicts with the existing footing and piling elements. Pile Design Tables are attached. Pile shoes should be used because both structure borings showed potential cobbles/boulders prior to auger refusal. All piles should be driven to refusal on the bedrock. Conflicts between the existing timber piling and existing concrete footing and the proposed pile locations are expected. The existing footing should be removed either completely or only at the proposed pile locations by coring in accordance with Article 501.04 of the Standard Specifications. In the event the proposed piling conflicts with existing timber piling, the proposed piling should be able to be driven through the existing timber piling without difficulty. Since the proposed piling will be driven to refusal on the bedrock, there is no need to reduce the pile capacity for piles placed in a cored hole or driven through the existing timber piles. Test piles are recommended at each abutment location to account for the bedrock's variable and inconsistent elevation.

An integral abutment feasibility analysis was also conducted and determined that the proposed structure may be an integral by using any of the H-pile sizes provided in the Pile Design Tables. Metal shell piles should not be used due to the potential for damage during driving.

Calculate the estimated water surface elevation and determine the need for cofferdams (type 1 or 2), and seal coat: Since the proposed structure is a single span bridge, cofferdams and seal coats are not needed.

Assess the need for sheeting or soil retention or temporary construction slope and provide recommendation for other construction concerns: Temporary sheet piling is not feasible because the maximum available embedment depth is less than the required embedment depth to design the sheet piling. Therefore, a temporary soil retention system will need to be designed by the Contractor and be included in the Contract plans. The existing structure needs to be removed as per 2016 Standard Specifications for Road and Bridge Construction, Section 501.

Project Location Map

FAP 553 (IL 72)
Section (125 BR-1)ES
DeKalb County
SN 019-0021
0.1 mile east of Ogle County line
Phase I Job No: P-93-036-17
Contract No. 66H52

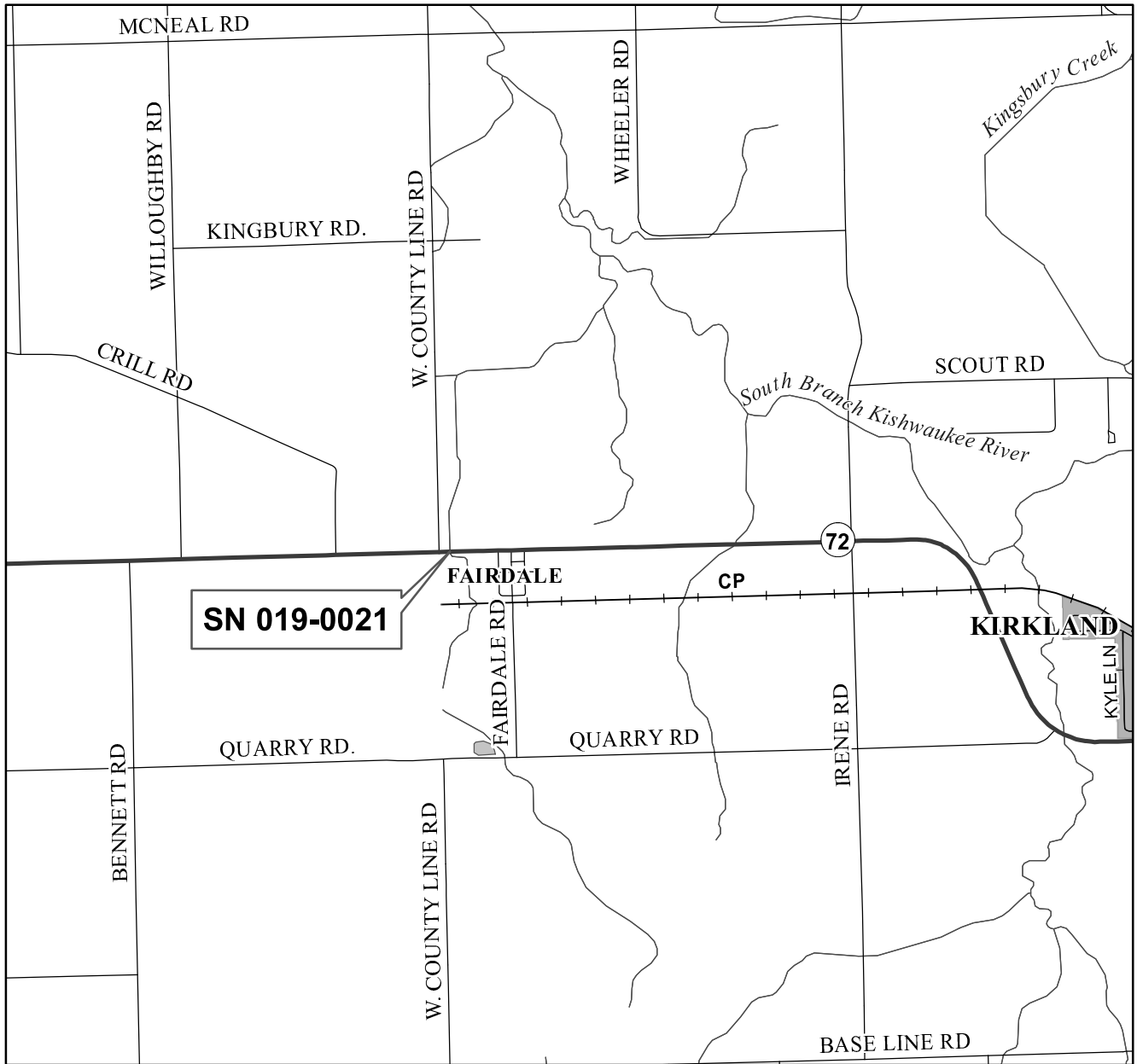
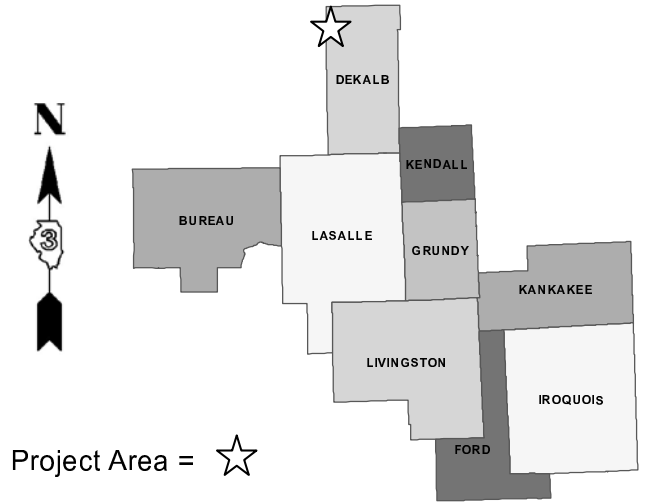

D3# 3382

Bench Mark: BM #18 Sta. 4+90.62, 40.37' LT
 Railroad Spike in power pole NE Quad of S.N. 019-0021.
 Elev. 764.19

Existing Structure: SN 019-0021 built 1930 as SBI Route 72 Section 125 at Sta. 3+72.5
 Re-built 1982 as FA Route 553 (IL 72). Structure consists of single span WF Beams
 and reinforced concrete deck supported by closed abutments on timber piles.
 41'-8 3/4" Bk to Bk of Abutments.
 34'-0" Out-to-Out Deck.
 Structure to be removed and replaced using stage construction.

** The bridge will be striped for 12' lanes

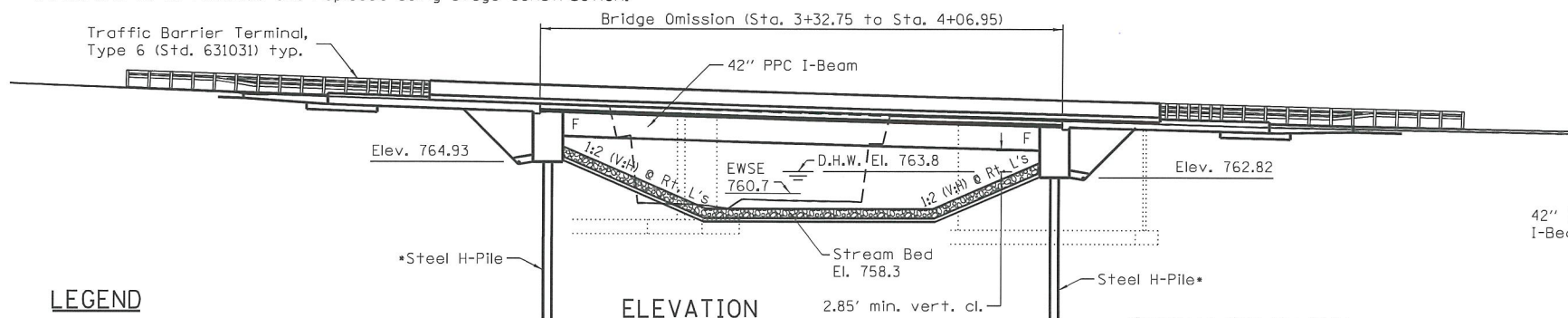

LEGEND

- A — overhead power line
- FO — buried fiber optic line
- - - - - toe of slope

ELEVATION

*Proposed piles should be driven to miss existing piles.

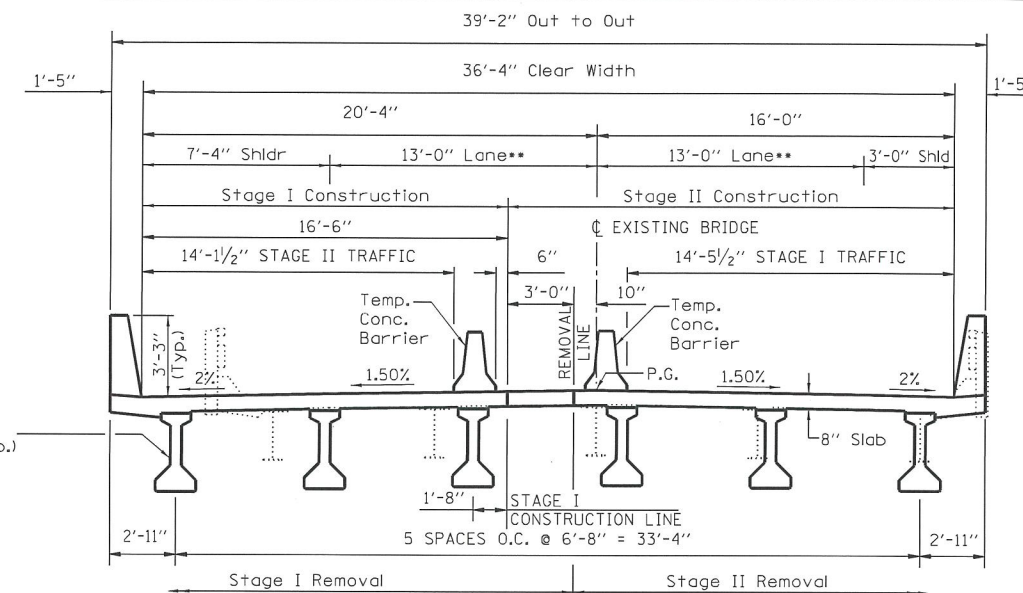

CROSS SECTION
(Looking East)

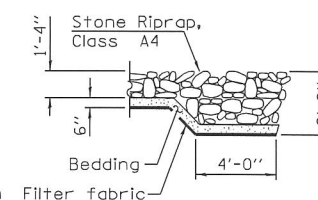

SECTION A-A

APPROVED

APR 24 2019

AS A BASIS FOR
 PREPARATION OF DETAILED PLANS

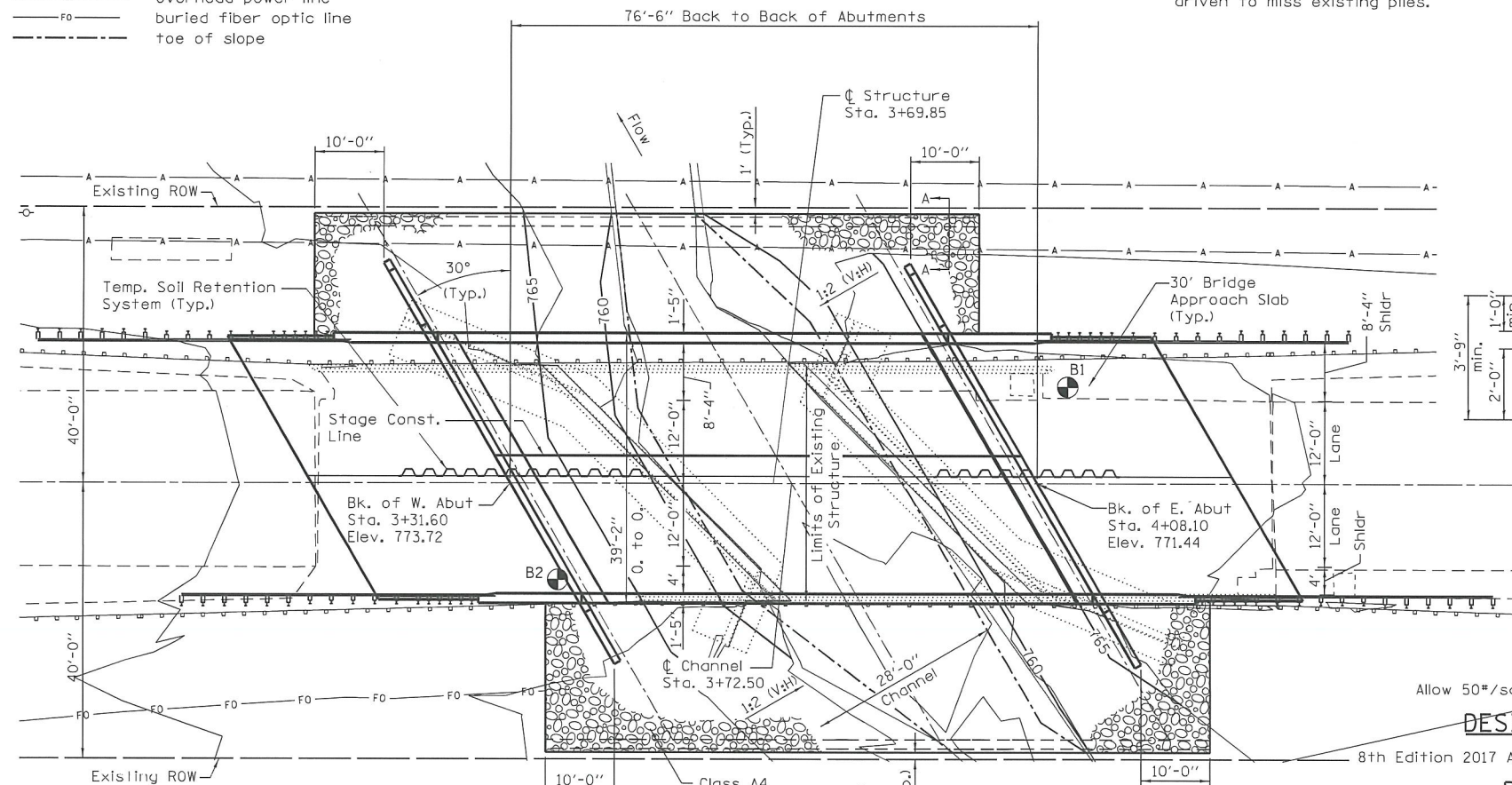

PLAN

SECTION THRU INTEGRAL ABUTMENT
(Horiz. dim. @ Rt. L's)

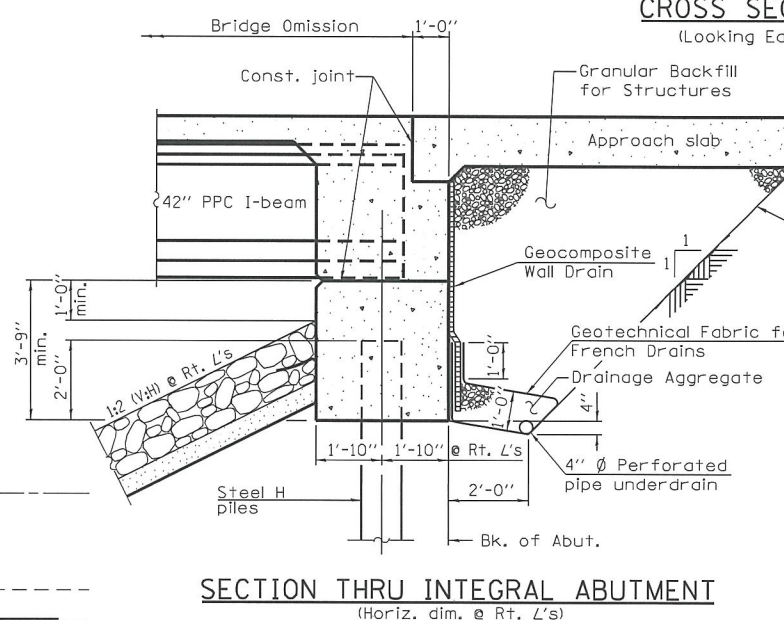

LOADING HL 93

Allow 50#/sq.ft. for future wearing surface

DESIGN SPECIFICATIONS

8th Edition 2017 AASHTO LRFD Bridge Design Specifications

DESIGN STRESSES

FIELD UNITS

f'c = 3,500 psi
 f'c = 4,000 psi (Superstructure Concrete)
 fy = 60,000 psi (reinforcement)

PRECAST PRESTRESSED UNITS

f'c = 6,000 psi
 f'cl = 5,000 psi
 fpu = 270,000 psi (1/2" low lax. strands)
 fpbt = 201,960 psi (1/2" low lax. strands)

SEISMIC DATA

Seismic Performance Zone (SPZ) = 1
 Design Spectral Acceleration at 1.0 sec. (SD1) = 0.058
 Design Spectral Acceleration at 0.2 sec. (SDS) = 0.107
 Soil Site Class = C

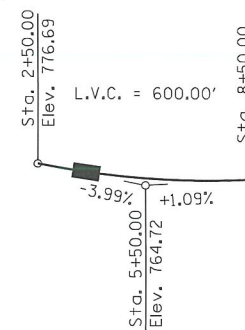

PROFILE GRADE
(along @ roadway)

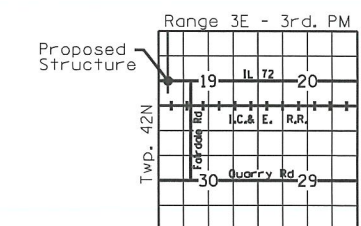

LOCATION SKETCH

GENERAL PLAN & ELEVATION

**IL 72 OVER TRIBUTARY TO
 KISHWAUKEE RIVER
 F.A.P. RTE. 553-SECTION (125BR-1)ES
 DEKALB COUNTY
 STATION 3+69.85
 SN 019-0050 (PROP.)**

WATERWAY INFORMATION

Drainage Area = 2.9 sq. mi.		Low Grade Elev. = 766.8 ft								
Flood	Freq. Yr.	Q C.F.S.	Opening Sq. Ft.	Net H.W.E.	Head - Ft.	Headwater El.	Exist.	Prop.	Exist.	Prop.
Hydraulic Design	10	330	81	109	763.3	0.7	0.4	764.1	763.7	763.7
Base/Scour Design	50	530	91	127	763.8	1.4	0.7	765.2	764.5	764.5
Scour Check	100	630	95	134	763.9	1.7	0.9	765.7	764.8	764.8
Max. Calc.	200	690	97	138	764	2.0	1.0	766.0	765.1	765.1
Overtopping	500	860	103	149	764.3	2.5	1.3	766.8	765.6	765.6
	N/A	N/A	N/A	N/A	N/A	N/A	N/A	N/A	N/A	N/A

DESIGN SCOUR ELEVATION TABLE

Event / Limit State	Design Scour Elevations (ft.)		
	W. Abut.	E. Abut.	Item 113
Q100	764.93	762.82	8
Q200	764.93	762.82	
Design	764.93	762.82	
Check	764.93	762.82	

FILE NAME = 0190050-66H52-TSL-001.dgn
CHAMLIN ASSOCIATES, INC.

USER NAME = CHAMLIN
 DESIGNED - JKC
 DRAWN - LAG
 CHECKED - JKC
 DATE - 1/15/19

REVISOR -
 REVISION -
 REVISION -
 REVISION -

**STATE OF ILLINOIS
 DEPARTMENT OF TRANSPORTATION**

SCALE: 1"=10'
 SHEET 1 OF 1 SHEETS
 STA. TO STA.

F.A. RTE.	SECTION	COUNTY	TOTAL SHEETS	SHEET NO.
553	(125BR-1)ES	DEKALB		
CONTRACT NO. 66H52				
ILLINOIS FED. AID PROJECT				



Illinois Department of Transportation

Division of Highways
Illinois Department of Transportation

SOIL BORING LOG

Date 5/22/18

ROUTE FAP 553 (IL 72) DESCRIPTION IL 72 over a Stream, 0.1 miles East of Ogle County Line LOGGED BY Larry Myers

SECTION 125BR-1 LOCATION SW 1/4, SEC. 19, TWP. 42N, RNG. 3E, 3rd PM, Latitude 42.101412, Longitude -88.938054

COUNTY Dekalb DRILLING METHOD Hollow Stem Auger HAMMER TYPE CME Automatic

STRUCT. NO. <u>019-0021 (Exist.)</u>	D E P T H H	B L O W S	U C S Qu	M O I S T	Surface Water Elev. <u>759.59</u> ft	D E P T H H	B L O W S	U C S Qu	M O I S T
Station <u>3+72.50</u>					Stream Bed Elev. <u>758.37</u> ft				
BORING NO. <u>02 (S.W. Quad.)</u>	ft (ft)	(ft)	(tsf)	(%)	Groundwater Elev.:	(ft)	(ft)	(ft)	(ft)
Station <u>3+38.5</u>					First Encounter <u>755.9</u> ft ▼				
Offset <u>14.0 ft Rt.</u>					Upon Completion <u>755.9</u> ft ▼				
Ground Surface Elev. <u>772.93</u> ft					After _____ Hrs. _____ ft				

Soil Description	Depth (ft)	Blow Count (ft)	UCS (tsf)	Moisture (%)	Surface Water Elev. (ft)	Depth (ft)	Blow Count (ft)	UCS (tsf)	Moisture (%)
Augered Bituminous Shoulder, Gravel Fill	770.43				751.93	56	100/0		23
Stiff to Very Stiff Black & Brown Silty Clay Loam Fill with Large Debris Pieces	-5	5 7	2.5 P	15					
Medium Orange Fine Sand to Coarse Gravel - Loamy Potential Cobble / Boulders	-10	6 4 2	1.5 P	20					
Stiff Pinkish Gray Silty Clay Loam Till	-15	1 6 8	2.0 P	11					
Very Dense Light Buff Weathered Limestone Gravel in Tan Silt Matrix	-20	3 6 19		16					
	-25	2 2 3	1.5 P	14					
	-30	35 60 68		18					
	-35								
	-40								

SOIL BORING 019-0021.GPJ IL_DOT.GDT 1/14/19

The Unconfined Compressive Strength (UCS) Failure Mode is indicated by (B-Bulge, S-Shear, P-Penetrometer)
The SPT (N value) is the sum of the last two blow values in each sampling zone (AASHTO T206)

MODEL: Default
 FILE: \\blm1c2.pw.us.ibm.com\data\illinois.gov\PIW\DOT\Documents\DOT_Offices\District_3\Projects\12366153_CADD\DATA\Geotechnical\12366153-xxx-ehh-01p11e.dgn

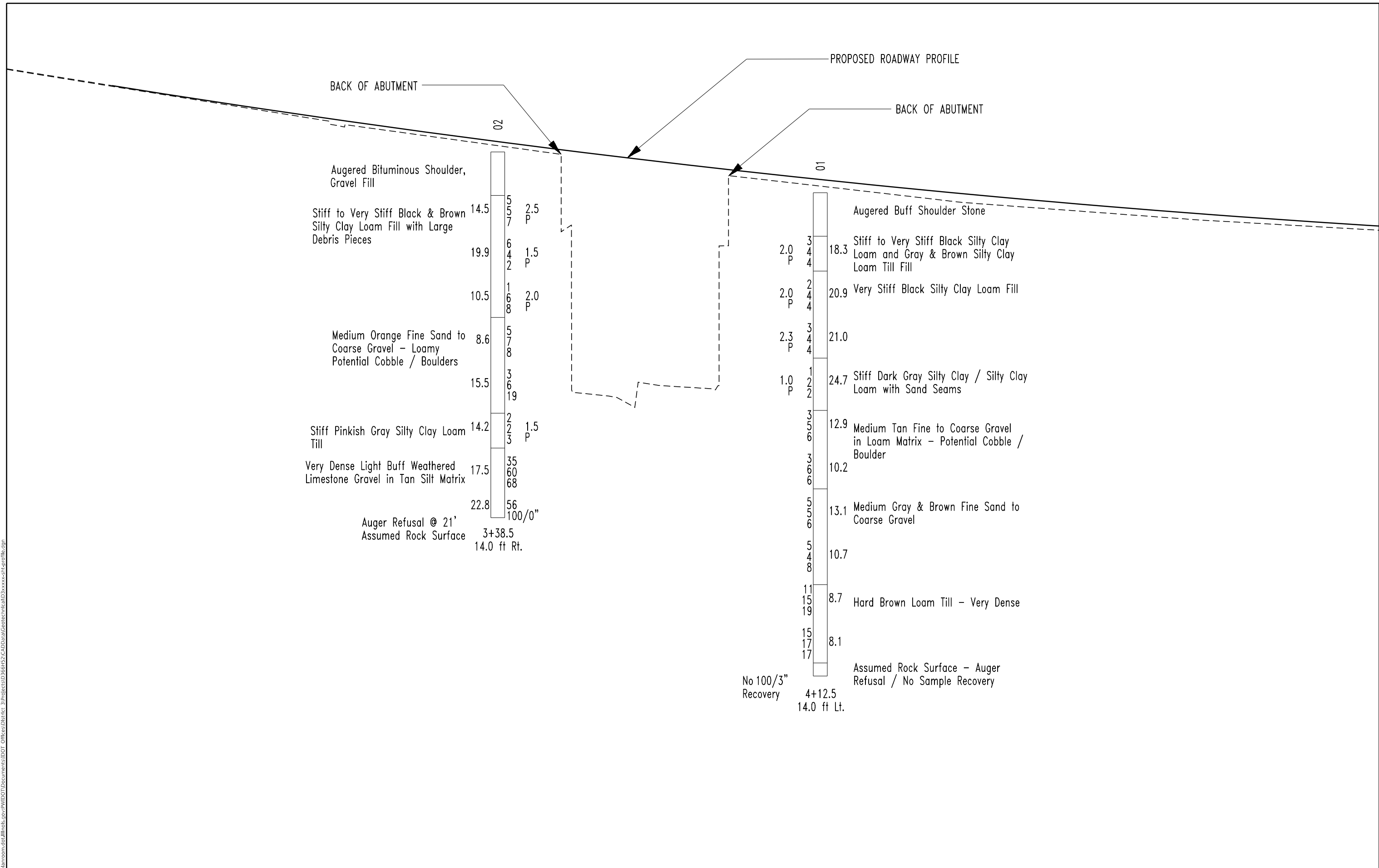

USER NAME = GrunstadAJ	DESIGNED - _____	REVISED - _____
	DRAWN - _____	REVISED - _____
PLOT SCALE = 20.0000' / in.	CHECKED - _____	REVISED - _____
PLOT DATE = 4/5/2019	DATE - _____	REVISED - _____

**STATE OF ILLINOIS
 DEPARTMENT OF TRANSPORTATION**

STRUCT. NO. 019-0021 (EXIST.) 019-0050 (PROP.)			
SCALE: _____	SHEET _____	OF _____	SHEETS
STA. _____	TO STA. _____		

F.A. RTE. _____	SECTION 125BR-1	COUNTY DEKALB	TOTAL SHEETS 1	SHEET NO. 1
			CONTRACT NO. 66H52	
		ILLINOIS FED. AID PROJECT		

PROJECT TITLE=====019-0050: IL 72 over Trib to So Branch Kishwaukee River

Substructure 1					
Base of Substruct. Elev. (or ground surf for bents)		764.68 ft.			
Pile or Shaft Dia.		12 inches			
Boring Number		B-02			
Top of Boring Elev.		772.93 ft.			
Approximate Fixity Elev.		758.68 ft.			
Individual Site Class Definition:					
N (bar):		71 (Blows/ft.)	Soil Site Class C		
N _{ch} (bar):		98 (Blows/ft.)	Soil Site Class C		
s _u (bar):		4.77 (ksf)	Soil Site Class C <---Controls		
Seismic Soil Column	Bot. Of Sample	Sample			Layer Description
Depth	Elevation	Thick.	N	Qu	Boundary
(ft)	(ft)	(ft)	(tsf)		
	770.4	2.50	0	0.25	B
	767.9	2.50	12	2.50	
	765.4	2.50	6	1.50	
	763.4	2.00	14	2.00	B
	760.9	2.50	15	0.00	
0.8	757.9	3.00	25	0.00	B
2.8	755.9	2.00	5	1.50	B
6.8	751.9	4.00	128	0.00	B
100.0	658.7	93.20	100	10.00	R

Substructure 2					
Base of Substruct. Elev. (or ground surf for bents)		762.32 ft.			
Pile or Shaft Dia.		12 inches			
Boring Number		B-01			
Top of Boring Elev.		770.59 ft.			
Approximate Fixity Elev.		756.32 ft.			
Individual Site Class Definition:					
N (bar):		59 (Blows/ft.)	Soil Site Class C <---Controls		
N _{ch} (bar):		59 (Blows/ft.)	Soil Site Class C		
s _u (bar):			NA, H < 0.1*H (Soil)		
Seismic Soil Column	Bot. Of Sample	Sample			Layer Description
Depth	Elevation	Thick.	N	Qu	Boundary
(ft)	(ft)	(ft)	(tsf)		
	768.1	2.50	0	0.25	B
	766.1	2.00	8	2.00	B
	763.6	2.50	8	2.00	
	761.1	2.50	8	2.30	B
	758.1	3.00	4	1.00	B
0.7	755.6	2.50	11	0.00	
2.7	753.6	2.00	12	0.00	B
5.2	751.1	2.50	11	0.00	
8.2	748.1	3.00	12	0.00	B
10.7	745.6	2.50	34	0.00	
12.7	743.6	2.00	34	0.00	B
100.0	656.3	87.30	100	10.00	R

Substructure 3					
Base of Substruct. Elev. (or ground surf for bents)		ft.			
Pile or Shaft Dia.		inches			
Boring Number					
Top of Boring Elev.		ft.			
Approximate Fixity Elev.		ft.			
Individual Site Class Definition:					
N (bar):		(Blows/ft.)	NA		
N _{ch} (bar):		(Blows/ft.)	NA		
s _u (bar):		(ksf)	NA		
Seismic Soil Column	Bot. Of Sample	Sample			Layer Description
Depth	Elevation	Thick.	N	Qu	Boundary
(ft)	(ft)	(ft)	(tsf)		

Substructure 4					
Base of Substruct. Elev. (or ground surf for bents)		ft.			
Pile or Shaft Dia.		inches			
Boring Number					
Top of Boring Elev.		ft.			
Approximate Fixity Elev.		ft.			
Individual Site Class Definition:					
N (bar):		(Blows/ft.)	NA		
N _{ch} (bar):		(Blows/ft.)	NA		
s _u (bar):		(ksf)	NA		
Seismic Soil Column	Bot. Of Sample	Sample			Layer Description
Depth	Elevation	Thick.	N	Qu	Boundary
(ft)	(ft)	(ft)	(tsf)		

Global Site Class Definition: Substructures 1 through 2					
N (bar):		65 (Blows/ft.)	Soil Site Class C		
N _{ch} (bar):		78 (Blows/ft.)	Soil Site Class C <---Controls		
s _u (bar):		4.88 (ksf)	Soil Site Class C		

Design Maps Summary Report

User-Specified Input

Report Title Design Spectral Acceleration
Wed December 5, 2018 14:36:29 UTC

Building Code Reference Document 2009 AASHTO Guide Specifications for LRFD Seismic Bridge Design
(which utilizes USGS hazard data available in 2002)

Site Coordinates 42.10144°N, 88.9379°W

Site Soil Classification Site Class C – “Very Dense Soil and Soft Rock”

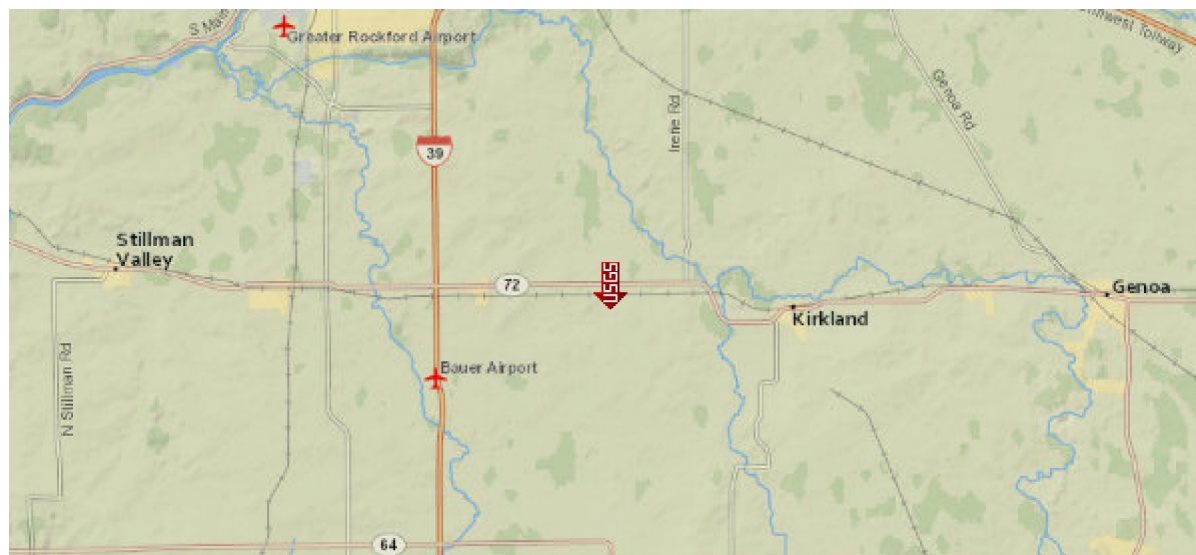

USGS-Provided Output

PGA = 0.042 g	A_s = 0.050 g
S_s = 0.089 g	S_{DS} = 0.107 g
S₁ = 0.034 g	S_{D1} = 0.058 g

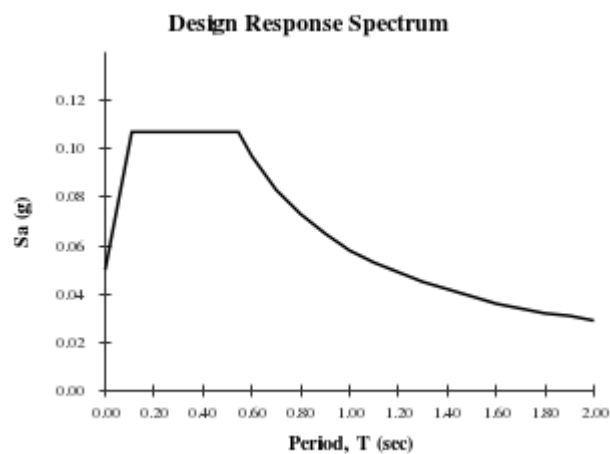

Although this information is a product of the U.S. Geological Survey, we provide no warranty, expressed or implied, as to the accuracy of the data contained therein. This tool is not a substitute for technical subject-matter knowledge.

GENERAL DATA

STRUCTURE NUMBER===== SN 019-0050
 STRUCTURE TYPE ===== SIMPLE-SPAN
 STRUCTURE SKEW===== 30 DEGREES
 SUPER. DATA IN REFERENCE TO SUB. DATA ===== ABUT 1
 TOTAL STRUCTURE LENGTH===== 76.50 FT

SUPERSTRUCTURE DATA (END OR MAIN SPAN)	
BEAM TYPE =====	CONCRETE BEAM
CONCRETE BEAM =====	42" PPC I-BEAM
BEAM F'C =====	6 KSI
BEAM SPACING PERP. TO CL =====	7.00 FT
SLAB THICKNESS =====	8.00 IN
SLAB F'C =====	4.00 KSI

SUPERSTRUCTURE DATA (ADJACENT SPAN)	
BEAM SPACING PERP. TO CL =====	FT

ABUTMENT #1 DATA	
ABUTMENT NAME =====	East
ABUTMENT REFERENCE BORING =====	B-01
BOTTOM OF ABUTMENT ELEVATION =====	762.32 FT
ESTIMATED NUMBER OF PILES AT ABUT. =====	6
PILE SPACING PERP. TO CL =====	5.75 FT

ABUTMENT #2 DATA	
ABUTMENT NAME =====	West
ABUTMENT REFERENCE BORING =====	B-02
BOTTOM OF ABUTMENT ELEVATION =====	764.68 FT
ESTIMATED NUMBER OF PILES AT ABUT. =====	6
PILE SPACING PERP. TO CL =====	5.75 FT

SOIL DATA FOR 10 FT BENEATH BOTTOM OF ABUTMENT #1				
BOT. OF LAYER ELEV. (FT)	LAYER THICKNESS (FT)	UNCONFINED COMPRESSIVE STRENGTH (TSF)	N S.P.T. VALUE (BLOWS/12 IN.)	Qu EQUIV. FOR N VALUE (TSF)
761.09	1.23	2.3		
758.09	3.00	1.0		
755.84	2.25		11	2.5
753.59	2.25		12	2.6
752.32	1.27		11	2.5

SOIL DATA FOR 10 FT BENEATH BOTTOM OF ABUTMENT #2				
BOT. OF LAYER ELEV. (FT)	LAYER THICKNESS (FT)	UNCONFINED COMPRESSIVE STRENGTH (TSF)	N S.P.T. VALUE (BLOWS/12 IN.)	Qu EQUIV. FOR N VALUE (TSF)
763.43	1.25	2.0		
760.93	2.50		15	2.7
757.93	3.00		25	3.1
755.93	2.00	1.50		
754.68	1.25		100	4.2

10.00 FT = TOTAL DEPTH ENTERED

10.00 FT = TOTAL DEPTH ENTERED

WEIGHTED AVERAGE Qu FOR ABUTMENT #1===== 2.04 TSF

WEIGHTED AVERAGE Qu FOR ABUTMENT #2===== 2.69 TSF

PILE STIFFNESS MODIFIER FOR ABUTMENT #1
 = 1/(1.45-[0.3*2.04])===== 1.19

PILE STIFFNESS MODIFIER FOR ABUTMENT #2
 = 1/(1.45-[0.3*2.69])===== 1.55

DISTANCE TO CENTROID OF STIFFNESS FROM ABUTMENT #1 = $[1.19*6*0+1.55*6*76.5]/[1.19*6+1.55*6]$ ===== 43.26 FT

DISTANCE TO CENTROID OF STIFFNESS FROM ABUTMENT #2 = $[1.55*6*0+1.19*6*76.5]/[1.55*6+1.19*6]$ ===== 33.24 FT

ABUT 1 (East) - EXPANSION LENGTH LIMIT CHART - 30.0 DEG. SKEW

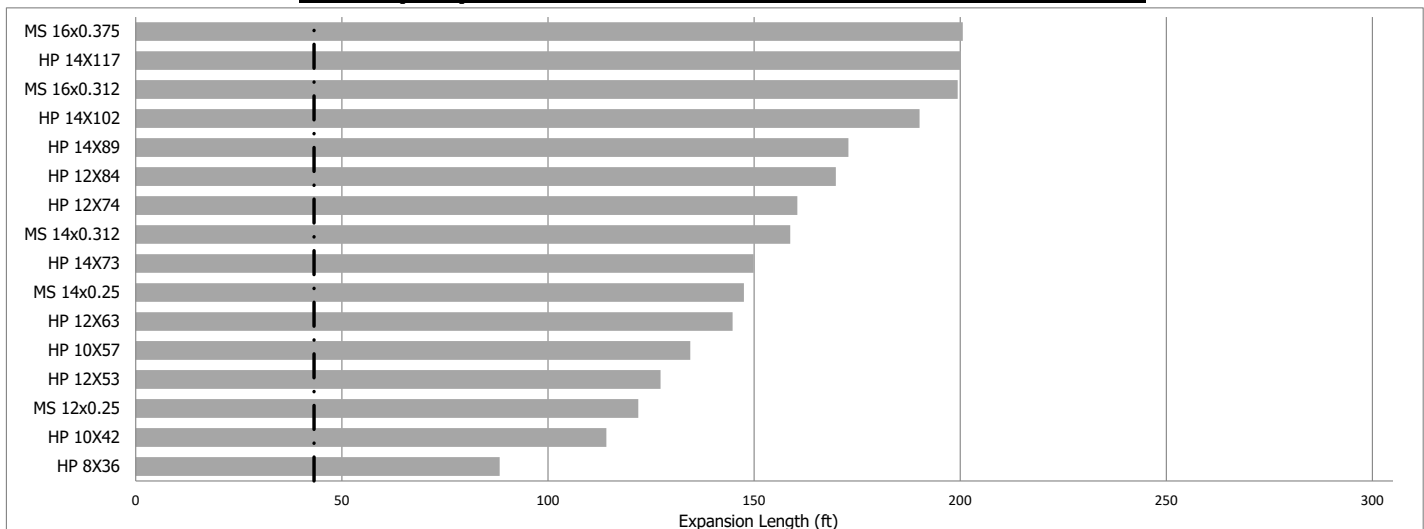

----- = Estimated expansion length for the indicated abutment. Piles with an expansion length greater than this are suitable for consideration.
 (Note: The same size pile should be used at both abutments.)

STATE OF ILLINOIS
DEPARTMENT OF PUBLIC WORKS & BUILDINGS
DIVISION OF HIGHWAYS

BOND ISSUE ROUTE NO.	SEC.	COUNTY	TOTAL SHEETS	SHEET NO.
72	125	DeKalb	61	56
FED. ROAD DIST. NO. 7		ILLINOIS	FED. AID PROJECT	

SHEET NO. 1
2 SHEETS

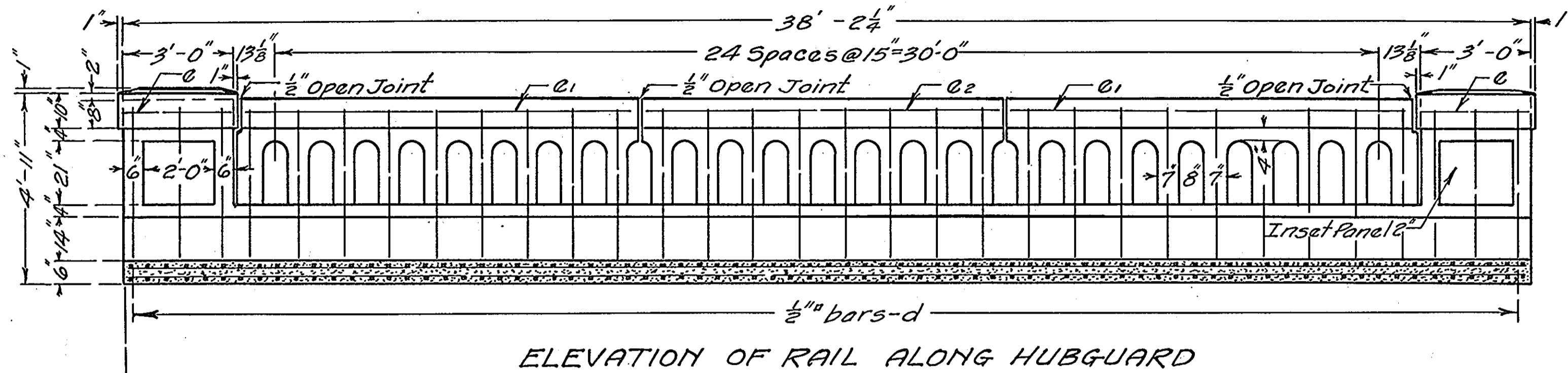

ELEVATION OF RAIL ALONG HUBGUARD

Rockers and Plates shall be given one coat of sublimed blue lead paint and two coats of white lead paint.
Surface of Plate adjacent to Rocker shall be planed.

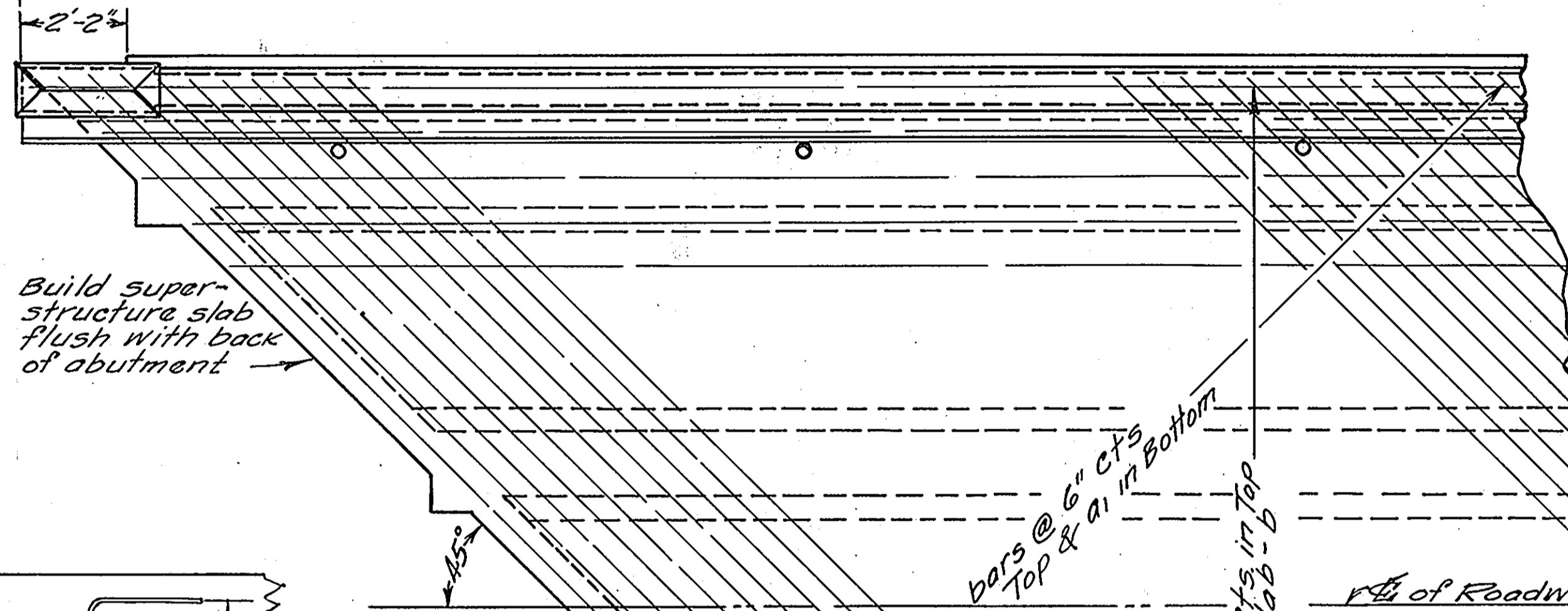
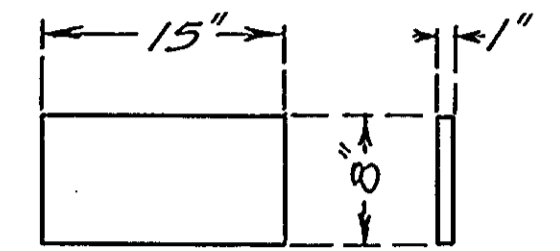
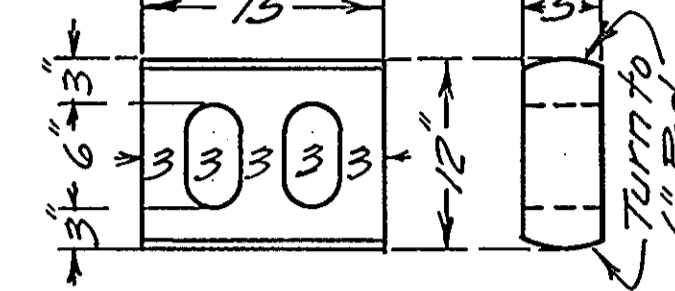

HALF CROSS SECTION

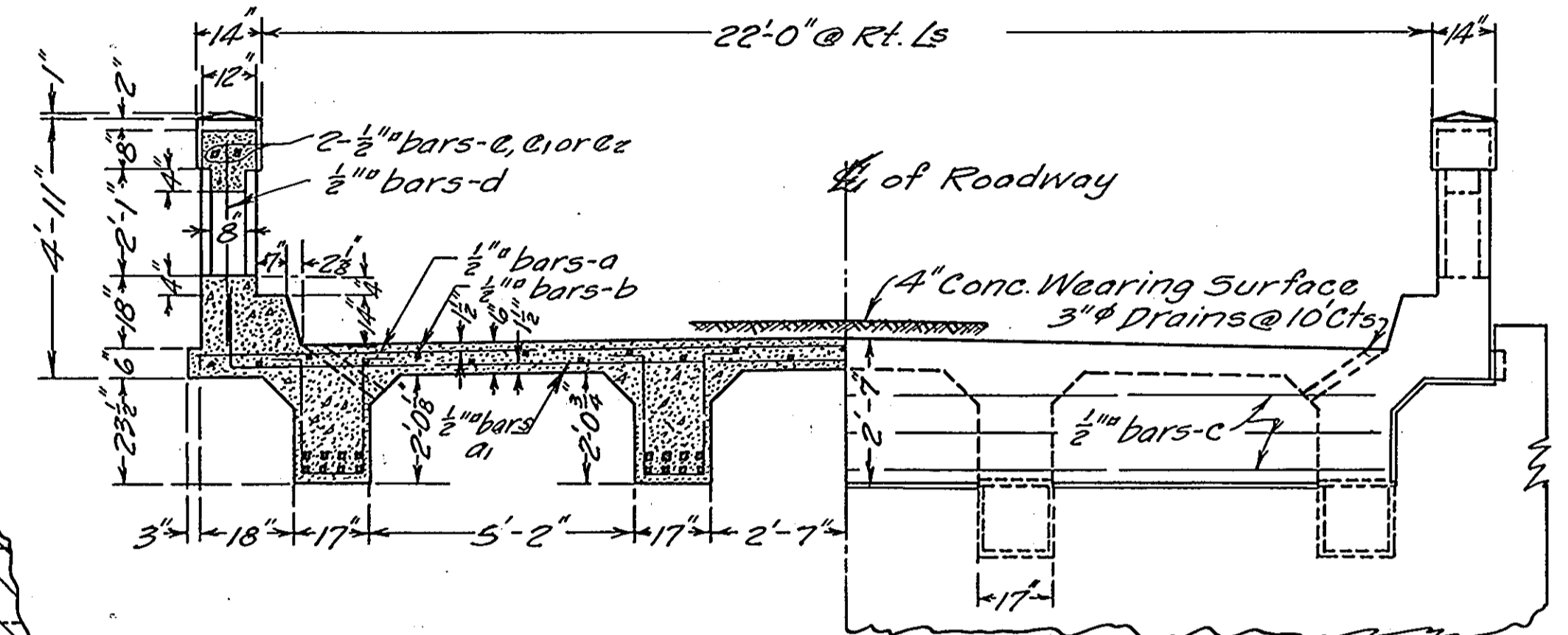

HALF END ELEVATION

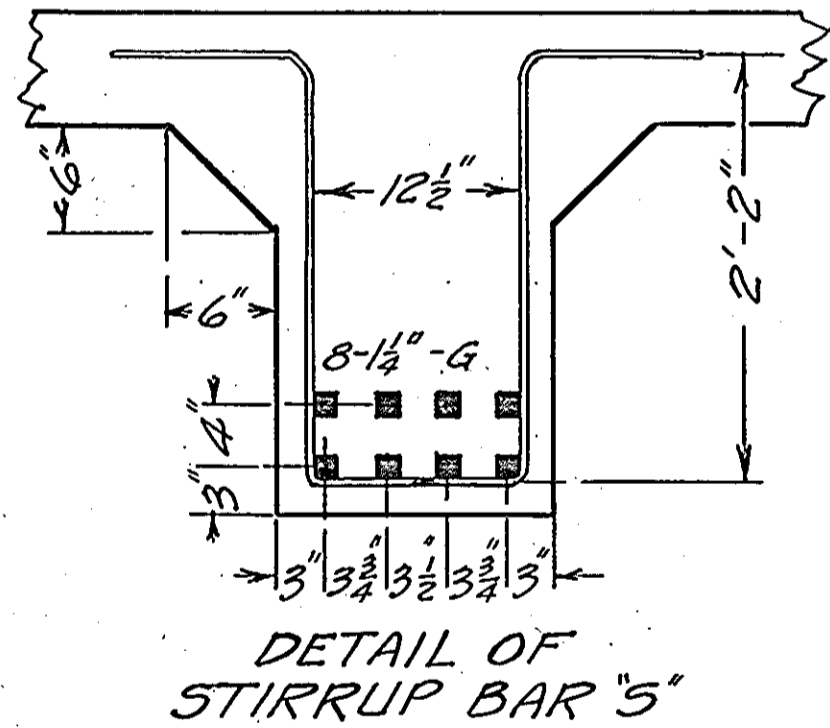

These dimensions for exp. end only see sketch below for fixed end.

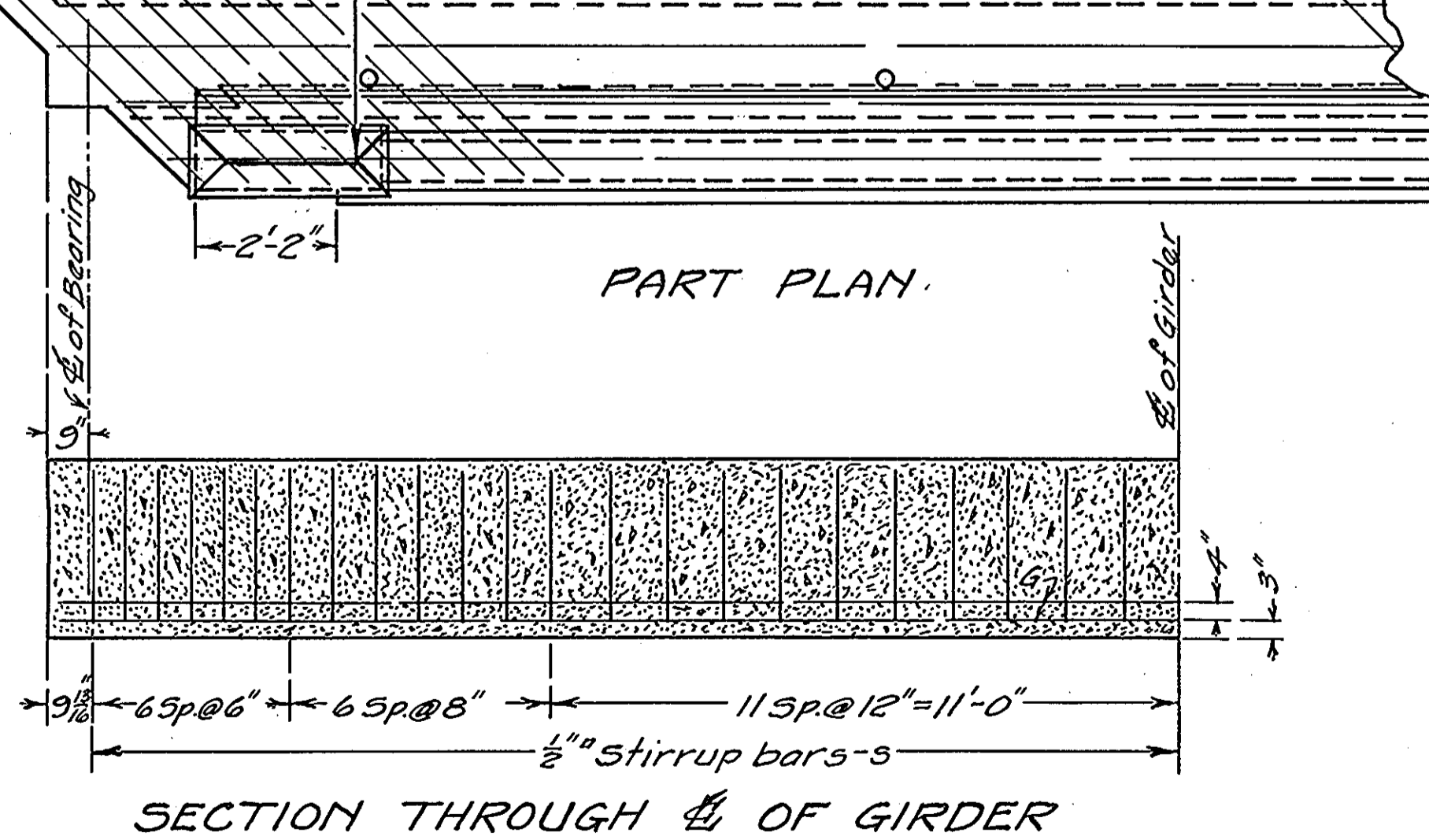
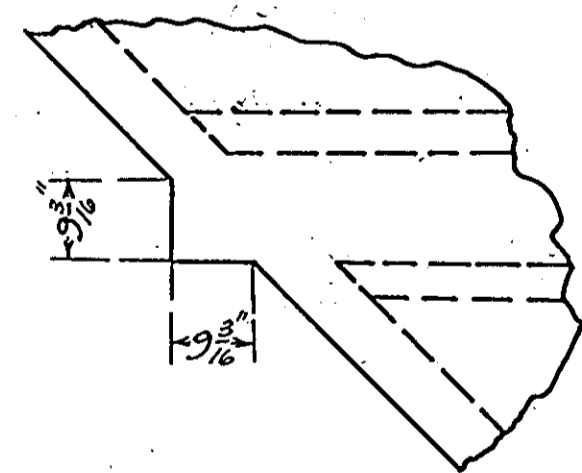

BILL OF MATERIAL

Bar No.	Size	Length
a	1/2" a	34'-6"
a1	1/2" a	36'-0"
b	1/2" b	20'-0"
c	1/2" c	29'-6"
d	1/2" d	4'-0"
e	1/2" e	2'-9"
e1	1/2" e	10'-9"
e2	1/2" e	9'-6"
G	1 1/4" G	37'-3"
S	1/2" S	7'-6"

Class X Concrete Cu. Yds. 41.8
Class X Conc. (Rail) Cu. Yds. 5.8
Reinforcing Steel - Lbs. 12040
4 C.I. Rockers - Lbs. 744
8 Steel Plates - Lbs. 270

Class X concrete shall be used throughout.
All reinforcing steel shall be wired securely in place before concrete is poured.

STANDARD	COMPUTED	<i>[Signature]</i>
	CHECKED	<i>[Signature]</i>
SPECIAL	DRAWN	<i>[Signature]</i>
	CHECKED	<i>[Signature]</i>
	ASSEMBLED	<i>[Signature]</i>
	CHECKED	<i>[Signature]</i>

EXAMINED July 30 1932
BRIDGE ENGINEER
PASSED
ENGINEER OF DESIGN
APPROVED
CHIEF HIGHWAY ENGINEER

S.B.I. ROUTE 72 SECTION 125
DEKALB COUNTY
STATION 3+72.5

STATE OF ILLINOIS
DEPARTMENT OF PUBLIC WORKS & BUILDINGS
DIVISION OF HIGHWAYS

ROUTE NO.	SEC.	COUNTY	TOTAL SHEETS	SHEET NO.
72	125	DeKalb	61	57

SHEET NO. 2
2 SHEETS

B.M. #1 - Form nail in root of 24" Box Elder
100' left Sta. -0+30. Elev. 188.47
Existing structure, 23' R.C. Slab, 16' Roadway,
to be removed by the Contractor.

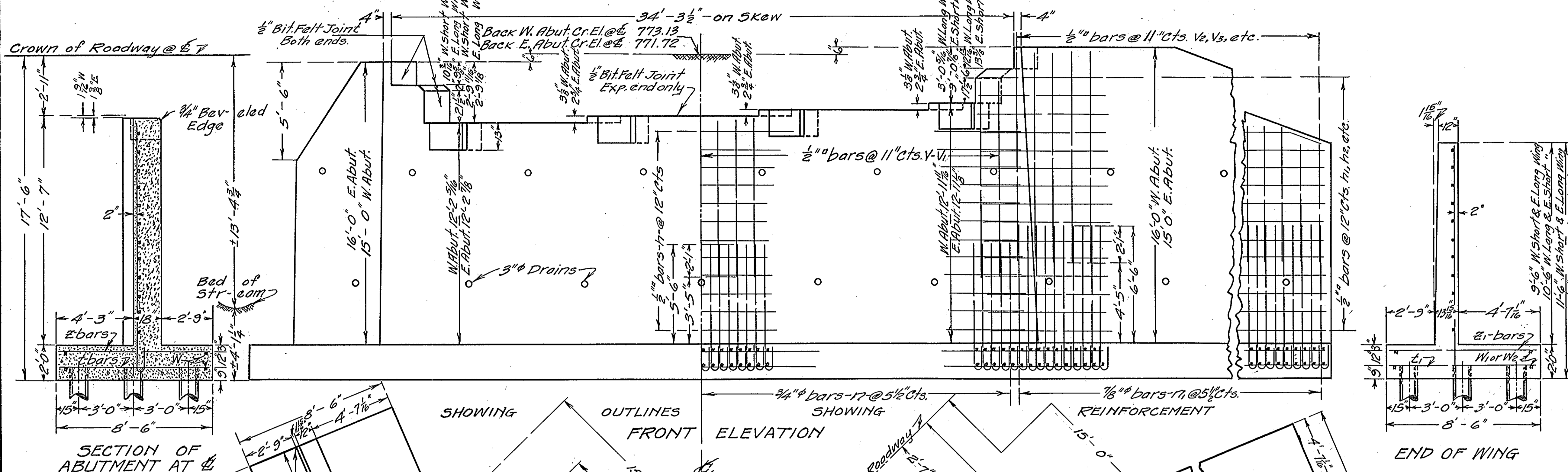

SECTION OF ABUTMENT AT $\frac{1}{4}$

Bar No.	Size	Length
V	68	1/2" 8'-9"
V1	8	1/2" 10'-9"
V2	15	1/2" 10'-0"
V3	9	1/2" 8'-6"
V4	10	1/2" 7'-0"
V5	9	1/2" 5'-6"
V6	15	1/2" 11'-0"
V7	9	1/2" 9'-6"
V8	10	1/2" 8'-0"
V9	9	1/2" 6'-6"

H	48	1/2" 18'-6"
H1	21	1/2" 13'-0"
H2	4	1/2" 10'-0"
H3	4	1/2" 7'-0"
H4	21	1/2" 30'-0"
H5	4	1/2" 24'-0"
H6	4	1/2" 18'-0"
T	152	3/4" 8'-6"
T1	170	1/8" 10'-0"
T2	166	3/4" 8'-3"
T3	188	1/2" 8'-3"
T4	134	1/2" 8'-3"
T5	160	1/2" 8'-3"
W	16	1/2" 20'-0"
W1	8	1/2" 29'-0"
W2	8	1/2" 13'-6"

Class X Concrete - Cu Yds. 188.4
Reinforcing Steel - Lbs. 14,330

Note: Class X concrete shall be used throughout.
All reinforcing steel shall be wired securely in place before concrete is poured.

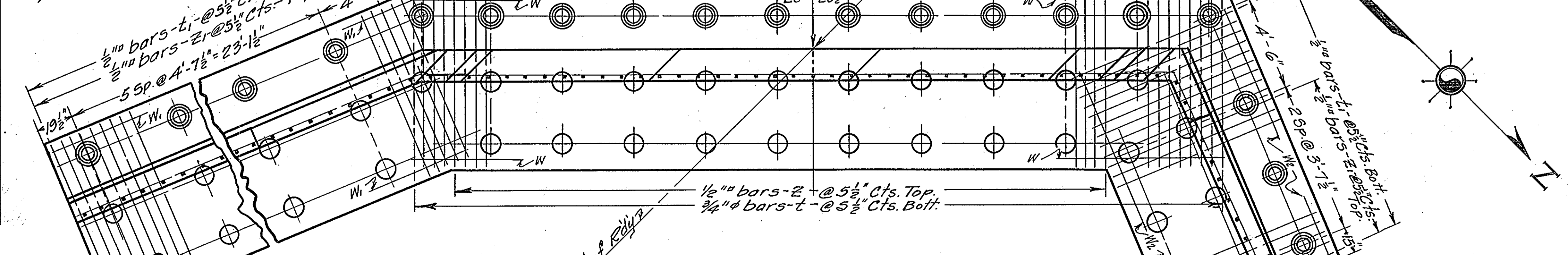

Bars in West short wing = 4V2, 3V3, 3V4, 3V5, 10H1, 2H2, 2H3, 4W2, 18Z1, 3T1, 26T2
Bars in East short wing = 4V6, 3V7, 3V8, 3V9, 11H1, 2H2, 2H3, 4W2, 18Z1, 3T1, 26T2
Bars in West long wing = 11V6, 6V7, 7V8, 6V9, 11H4, 2H5, 2H6, 4W1, 6Z1, 6Z2, 6Z3, 59T1
Bars in East long wing = 11V6, 6V7, 7V8, 6V9, 10H4, 2H5, 2H6, 4W1, 6Z1, 6Z2, 6Z3, 59T1

COMPUTED	- J.M. Romine
CHECKED	- M. Humphreys
DRAWN	- [Signature]
CHECKED	- [Signature]
ASSEMBLED	- [Signature]
CHECKED	- [Signature]

EXAMINED July 30 1920
J. F. Burch BRIDGE ENGINEER
PASSED [Signature] ENGINEER OF DESIGN
APPROVED [Signature] CHIEF HIGHWAY ENGINEER

- 15 Ton Untreated Piling. 12" Butt, 8" Tip. 42 Req'd. Estimated Length 840 Lin. Ft.
- 10 Ton Untreated Piling. 12" Butt, 8" Tip. 76 Req'd. Estimated Length 1520 Lin. Ft.

S.B.I. ROUTE 72 - SECTION 125
DEKALB COUNTY
STATION 3+72.5

IL 72 over South Branch of Kishwaukee River (SN 019-0050(P))
Information for SGR Consultant

By: JKC

Ck'd By: **AJD**

Kips
 Dead Load of West Abutment w/ Bottom Elev. = 764.68* 225.70
 Dead Load of East Abutment w/ bottom Elev. = 762.32* 227.50
 * - Does not include weight of dog ear wingwalls

Approach Slab Dead Load Reaction at Abutments
 West 103.10
 East 103.10

Approach Slab Wearing Surface Reaction at Abutments
 West 23.70
 East 23.70

Beam Dead Load Reactions (One Beam): Abutment
 Non-composite (DC1) 42.52
 Composite (DC2) 5.42
Wearing Surface 10.95
 One Beam Total 58.89
 # of Beams 6.00
Six Beam Total 353.34

W/o Impact
 Single Lane Load Reaction at Abutment 99.30

Calculate Total Load on Abutment - Single Lane Load							
Load Combination	DC		DW		LL		Total Load on Abutment
	FACTOR	LOAD	FACTOR	LOAD	FACTOR	LOAD	LOAD
Strength I	1.25	618.1	1.5	89.4	1.75	99.3	1080.5
Strength II	1.25	618.1	1.5	89.4	1.35	99.3	1040.78
Strength IV	1.5	618.1	1.5	89.4	0	99.3	1061.25
Service I	1	618.1	1	89.4	1	99.3	806.8

Calculate Total Load on Abutment - Two Lanes Loaded							
Load Combination	DC		DW		LL		Total Load on Abutment
	FACTOR	LOAD	FACTOR	LOAD	FACTOR	LOAD	LOAD
Strength I	1.25	618.1	1.5	89.4	1.75	198.6	1254.275
Strength II	1.25	618.1	1.5	89.4	1.35	198.6	1174.835
Strength IV	1.5	618.1	1.5	89.4	0	198.6	1061.25
Service I	1	618.1	1	89.4	1	198.6	906.1

Calculate Total Load on Abutment - Three Lanes Loaded							
Load Combination	DC		DW		LL		Total Load on Abutment
	FACTOR	LOAD	FACTOR	LOAD	FACTOR	LOAD	LOAD
Strength I	1.25	618.1	1.5	89.4	1.75	238.3	1323.75
Strength II	1.25	618.1	1.5	89.4	1.35	238.3	1228.43
Strength IV	1.5	618.1	1.5	89.4	0	238.3	1061.25
Service I	1	618.1	1	89.4	1	238.3	945.8

SUBSTRUCTURE=====019-0050 EAST ABUTMENT
 REFERENCE BORING ===== 1
 LRFD or ASD or SEISMIC ===== LRFD
 PILE CUTOFF ELEV. ===== 764.57 ft
 GROUND SURFACE ELEV. AGAINST PILE DURING DRIVING = 762.57 ft
 GEOTECHNICAL LOSS TYPE (None, Scour, Liquef., DD) ===== None
 BOTTOM ELEV. OF SCOUR, LIQUEF., or DD ===== ft
 TOP ELEV. OF LIQUEF. (so layers above apply DD) ===== ft

MAX. REQUIRED BEARING & RESISTANCE for Selected Pile, Soil Profile, & Losses

Maximum Nominal Req'd Bearing of Pile	Maximum Nominal Req'd Bearing of Boring	Maximum Factored Resistance Available in Boring	Maximum Pile Driveable Length in Boring
929 KIPS	917 KIPS	504 KIPS	25 FT.

TOTAL FACTORED SUBSTRUCTURE LOAD ===== 1324 kips
 TOTAL LENGTH OF SUBSTRUCTURE (along skew)===== 42.00 ft
 NUMBER OF ROWS OF PILES PER SUBSTRUCTURE ===== 1

Approx. Factored Loading Applied per pile at 8 ft. Cts ===== 252.19 KIPS
 Approx. Factored Loading Applied per pile at 3 ft. Cts ===== 94.57 KIPS

PILE TYPE AND SIZE ===== Steel HP 14 X 117

Pile Perimeter===== 4.850 FT. Unplugged Pile Perimeter===== 7.117 FT.
 Pile End Bearing Area===== 1.469 SQFT. Unplugged Pile End Bearing Area===== 0.239 SQFT.

BOT. OF LAYER ELEV. (FT.)	LAYER THICK. (FT.)	UNCONF. COMPR. STRENGTH (TSF.)	S.P.T. N VALUE (BLOWS)	GRANULAR OR ROCK LAYER DESCRIPTION	NOMINAL			NOMINAL UNPLUG'D			NOMINAL REQ'D BEARING (KIPS)	FACTORED GEOTECH. LOSS FROM SCOUR or DD (KIPS)	FACTORED GEOTECH. LOSS LOAD FROM DD (KIPS)	FACTORED RESISTANCE AVAILABLE (KIPS)	ESTIMATED PILE LENGTH (FT.)
					SIDE RESIST. (KIPS)	END BRG. RESIST. (KIPS)	TOTAL RESIST. (KIPS)	SIDE RESIST. (KIPS)	END BRG. RESIST. (KIPS)	TOTAL RESIST. (KIPS)					
761.09	1.48	2.30	8		9.1	29.7	13.4	17	16.8	17	0	0	9	3	
758.09	3.00	1.00	4		10.3	20.6	43.6	33	32.5	33	0	0	18	6	
755.59	2.50		11	Sandy Gravel	3.1	24.1	56.4	39	38.7	39	0	0	21	9	
753.59	2.00		12	Sandy Gravel	2.7	33.8	64.9	44	43.6	44	0	0	24	11	
751.09	2.50		11	Sandy Gravel	3.1	39.6	72.4	49	48.9	49	0	0	27	13	
748.09	3.00		12	Sandy Gravel	4.1	43.9	125.9	63	62.9	63	0	0	35	16	
747.09	1.00		34	Hard Till	1.8	93.3	127.7	66	65.5	66	0	0	36	17	
746.09	1.00		34	Hard Till	1.8	93.3	129.5	68	68.2	68	0	0	38	18	
745.59	0.50		34	Hard Till	0.9	93.3	130.4	70	69.5	70	0	0	38	19	
744.59	1.00		34	Hard Till	1.8	93.3	132.2	72	72.2	72	0	0	40	20	
743.59	1.00		34	Hard Till	1.8	93.3	406.7	119	119.2	119	0	0	66	21	
742.59	1.00			Limestone	120.8	366.1	527.6	296	296.5	296	0	0	163	22	
741.59	1.00			Limestone	120.8	366.1	648.4	474	473.8	474	0	0	261	23	
740.59	1.00			Limestone	120.8	366.1	769.2	651	651.1	651	0	0	358	24	
739.59	1.00			Limestone	120.8	366.1	890.1	828	828.4	828	0	0	456	25	
739.09	0.50			Limestone	60.4	366.1	950.5	917	917.1	917	0	0	504	25.5	
738.59	0.50			Limestone	60.4	366.1	1010.9	1006	1005.7	1006	0	0	553	26	
738.09	0.50			Limestone		366.1									

SUBSTRUCTURE=====019-0050 WEST ABUTMENT
 REFERENCE BORING ===== 2
 LRFD or ASD or SEISMIC ===== LRFD
 PILE CUTOFF ELEV. ===== 766.93 ft
 GROUND SURFACE ELEV. AGAINST PILE DURING DRIVING = 764.93 ft
 GEOTECHNICAL LOSS TYPE (None, Scour, Liquef., DD) ===== None
 BOTTOM ELEV. OF SCOUR, LIQUEF., or DD ===== ft
 TOP ELEV. OF LIQUEF. (so layers above apply DD) ===== ft

MAX. REQUIRED BEARING & RESISTANCE for Selected Pile, Soil Profile, & Losses

Maximum Nominal Req'd Bearing of Pile	Maximum Nominal Req'd Bearing of Boring	Maximum Factored Resistance Available in Boring	Maximum Pile Driveable Length in Boring
929 KIPS	903 KIPS	496 KIPS	16 FT.

TOTAL FACTORED SUBSTRUCTURE LOAD ===== 1324 kips
 TOTAL LENGTH OF SUBSTRUCTURE (along skew)===== 42.00 ft
 NUMBER OF ROWS OF PILES PER SUBSTRUCTURE ===== 1

Approx. Factored Loading Applied per pile at 8 ft. Cts ===== 252.19 KIPS
 Approx. Factored Loading Applied per pile at 3 ft. Cts ===== 94.57 KIPS

PILE TYPE AND SIZE ===== Steel HP 14 X 117

Pile Perimeter===== 4.850 FT. Unplugged Pile Perimeter===== 7.117 FT.
 Pile End Bearing Area===== 1.469 SQFT. Unplugged Pile End Bearing Area===== 0.239 SQFT.

BOT. OF LAYER ELEV. (FT.)	LAYER THICK. (FT.)	UNCONF. COMPR. STRENGTH (TSF.)	S.P.T. N VALUE (BLOWS)	GRANULAR OR ROCK LAYER DESCRIPTION	NOMINAL			NOMINAL UNPLUG'D			NOMINAL REQ'D BEARING (KIPS)	FACTORED GEOTECH. LOSS FROM SCOUR or DD (KIPS)	FACTORED GEOTECH. LOSS LOAD FROM DD (KIPS)	FACTORED RESISTANCE AVAILABLE (KIPS)	ESTIMATED PILE LENGTH (FT.)
					SIDE RESIST. (KIPS)	END BRG. RESIST. (KIPS)	TOTAL RESIST. (KIPS)	SIDE RESIST. (KIPS)	END BRG. RESIST. (KIPS)	TOTAL RESIST. (KIPS)					
763.43	1.50	2.00	14		8.5	27.3	12.4	15.5	15	0	0	9	4		
760.93	2.50		15	Sandy Gravel	4.2	18.8	67.6	6.2	3.1	27.6	28	0	15	6	
757.93	3.00		25	Sandy Gravel	8.8	54.9	52.4	12.9	8.9	36.5	37	0	20	9	
755.93	2.00	1.50	5		9.3	30.9	396.9	13.7	5.0	104.7	105	0	58	11	
754.93	1.00			Limestone	120.8	366.1	517.7	177.3	59.5	282.0	282	0	155	12	
753.93	1.00			Limestone	120.8	366.1	638.5	177.3	59.5	459.3	459	0	253	13	
752.93	1.00			Limestone	120.8	366.1	759.4	177.3	59.5	636.6	637	0	350	14	
751.93	1.00			Limestone	120.8	366.1	880.2	177.3	59.5	813.9	814	0	448	15	
751.43	0.50			Limestone	60.4	366.1	940.6	88.7	59.5	902.6	903	0	496	15.5	
750.93	0.50			Limestone	60.4	366.1	1001.0	88.7	59.5	991.3	994	0	545	16	
750.43	0.50			Limestone	60.4	366.1	1061.5	88.7	59.5	1079.9	1064	0	584	16.5	
749.93	0.50			Limestone		366.1			59.5						

SN 019-0050		DEKALB COUNTY	
IL 72 OVER TRIBUTARY TO SOUTH BRANCH OF KISHWAUKEE RIVER			
PILE LENGTH TABLE: EAST ABUTMENT USING BORING #1			
ALL PILES SHOULD BE DRIVEN TO REFUSAL ON THE BEDROCK SURFACE			
PILE CUTOFF ELEVATION 764.57			
PILE TYPE AND SIZE	NOMINAL REQUIRED BEARING	FACTORED RESISTANCE AVAILABLE	ESTIMATED PILE LENGTH
	KIPS	KIPS	FEET
Steel HP 8 X 36	245	135	23
Steel HP 8 X 36	286	157	23
Steel HP 10 X 42	304	167	23
Steel HP 10 X 42	335	184	23
Steel HP 10 X 57	435	239	24
Steel HP 10 X 57	454	250	24
Steel HP 12 X 53	364	200	23
Steel HP 12 X 53	419	230	23
Steel HP 12 X 63	374	206	23
Steel HP 12 X 63	497	273	24
Steel HP 12 X 74	529	291	24
Steel HP 12 X 74	589	324	24
Steel HP 12 X 84	536	295	24
Steel HP 12 X 84	664	365	25
Steel HP 14 X 73	443	244	23
Steel HP 14 X 73	578	318	24
Steel HP 14 X 89	630	346	24
Steel HP 14 X 89	705	388	24
Steel HP 14 X 102	639	351	24
Steel HP 14 X 102	810	446	25
Steel HP 14 X 117	917	504	25
Steel HP 14 X 117	929	511	26

SN 019-0050		DEKALB COUNTY	
IL 72 OVER TRIBUTARY TO SOUTH BRANCH OF KISHWAUKEE RIVER			
PILE LENGTH TABLE: WEST ABUTMENT USING BORING #2			
ALL PILES SHOULD BE DRIVEN TO REFUSAL ON THE BEDROCK SURFACE			
PILE CUTOFF ELEVATION 766.93			
PILE TYPE AND SIZE	NOMINAL REQUIRED BEARING	FACTORED RESISTANCE AVAILABLE	ESTIMATED PILE LENGTH
	KIPS	KIPS	FEET
Steel HP 8 X 36	237	130	13
Steel HP 8 X 36	286	157	13
Steel HP 10 X 42	294	162	13
Steel HP 10 X 42	335	184	13
Steel HP 10 X 57	425	234	14
Steel HP 10 X 57	454	250	14
Steel HP 12 X 53	353	194	13
Steel HP 12 X 53	419	230	13
Steel HP 12 X 63	362	199	13
Steel HP 12 X 63	497	273	14
Steel HP 12 X 74	517	284	14
Steel HP 12 X 74	589	324	14
Steel HP 12 X 84	524	288	14
Steel HP 12 X 84	664	365	15
Steel HP 14 X 73	429	236	13
Steel HP 14 X 73	578	318	14
Steel HP 14 X 89	616	339	14
Steel HP 14 X 89	705	388	15
Steel HP 14 X 102	800	440	15
Steel HP 14 X 102	810	446	15
Steel HP 14 X 117	903	496	16
Steel HP 14 X 117	929	511	16