

EXISTING TYPICAL RAMP G SECTION

EXISTING LEGEND

- (A) EXISTING AGGREGATE SHOULDER, TYPE B
- (B) EXISTING BITUMINOUS SHOULDER, 8"
- (C) EXISTING SUB-SURFACE DRAINS
- (D) EXISTING BITUMINOUS SURFACE COURSE, MIXTURE D 1 1/2"
- (E) EXISTING BITUMINOUS BINDER COURSE 3"
- (F) EXISTING P.C.C. PAVEMENT, 8"
- (G) EXISTING SUB-BASE GRANULAR MATERIAL, TYPE A 4"

PROPOSED LEGEND

- (1) HOT-MIX ASPHALT REMOVAL, 1 1/2"
- (2) HOT-MIX ASPHALT REMOVAL, VARIABLE DEPTH (1 1/2" LEFT TO 4 1/2" RIGHT) - (FOR SUPERELEVATION CORRECTION)
- (3) LEVELING BINDER (MACHINE METHOD), N70 3/4" & VARIES
- (4) HOT-MIX ASPHALT SURFACE COURSE, MIX D, N70 (1 1/2")
- (5) STRIP REFLECTIVE CRACK CONTROL TREATMENT
- (6) AGGREGATE WEDGE SHOULDER, TYPE B
- (7) COMBINATION CONCRETE CURB AND GUTTER REMOVAL AND REPLACEMENT
- (8) REMOVAL AND REINSTALLATION OF EXISTING STEEL PLATE BEAM GUARD RAIL, SINGLE RAIL

HOT-MIX ASPHALT MIXTURE REQUIREMENTS CHART

OPERATIONS	MIXTURE TYPE	AC TYPE	PERCENT AIR VOIDS
RAMPS & SHOULDERS	HOT-MIX ASPHALT SURFACE COURSE, MIX "D", N70	PG 64-22	4% @ 70 GYR.
	LEVELING BINDER (MACHINE METHOD), N70	PG 64-22 *	4% @ 70 GYR.

NOTE:  
 THE UNIT WEIGHT USED TO CALCULATE ALL HMA SURFACE MIXTURES QUANTITIES IS 112 LBS/SOYD/IN  
 \* WHEN RAP EXCEEDS 20%, THE NEW ASPHALT BINDER IN THE MIX SHALL BE PG 58-22

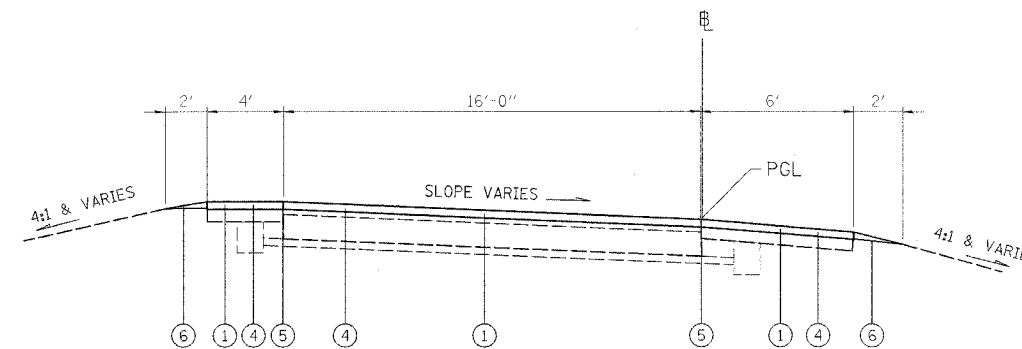

PROPOSED TYPICAL RAMP G SECTION  
 STA. 108+13 TO STA. 112+29.30

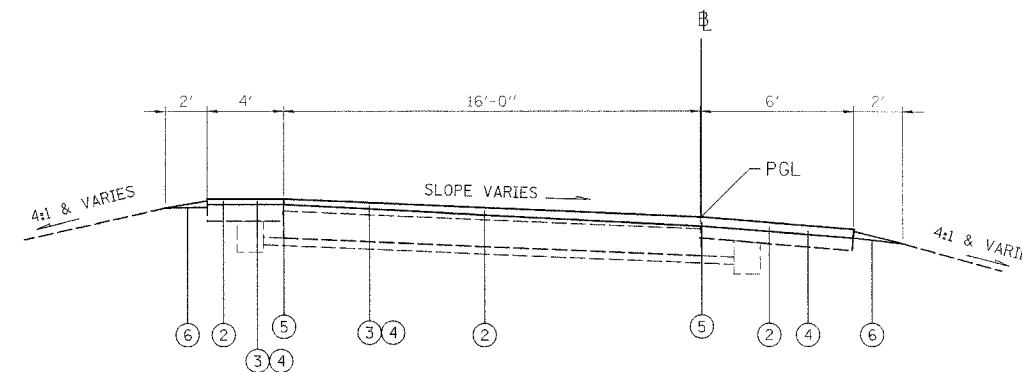

PROPOSED TYPICAL RAMP G SECTION  
 STA. 112+29.30 TO STA. 113+75

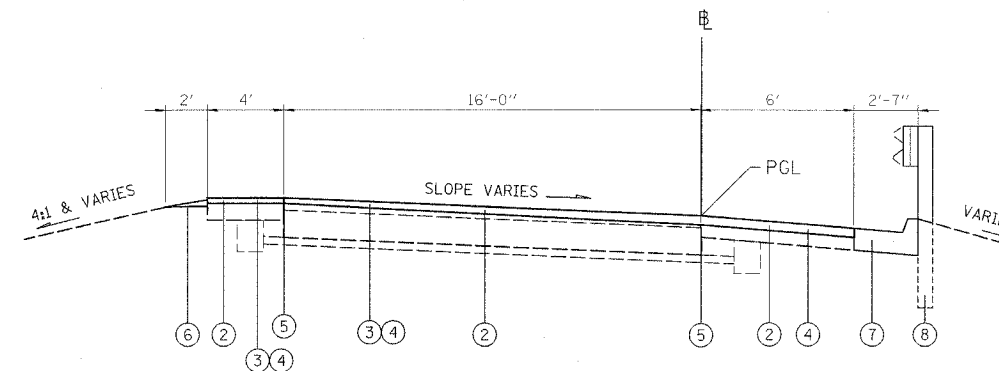

PROPOSED TYPICAL RAMP G SECTION  
 STA. 113+75 TO STA. 115+00

FILE NAME = N:\PROJ\3329\3329\_02\Design\Main\Drawings\3329\02-Typical Sections.dgn