

F.A.P. RYE.	SECTION	COUNTY	TOTAL SHEETS	SHEET NO.
347	(C&U)R-RS-2	OuPage	18	18A.
FED. ROAD DIST. NO.		ILLINOIS	FED. AID PROJECT	

Contract 60042

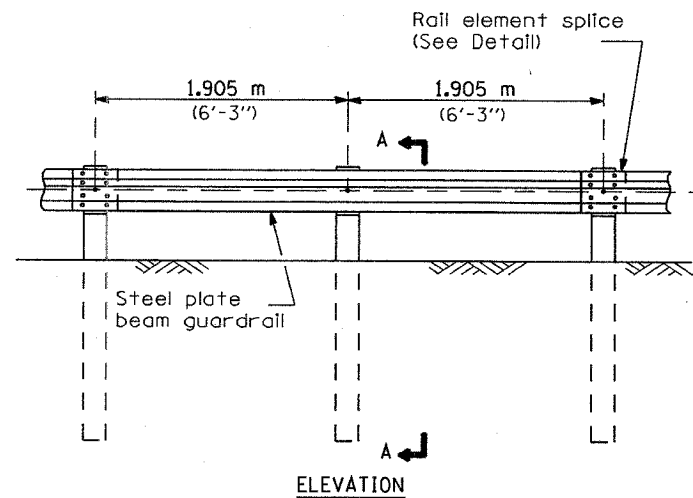

TYPE A

1.905 m (6'-3") Typical post spacing

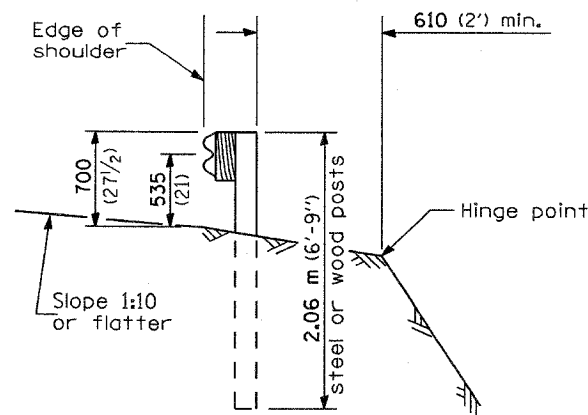

SECTION A-A

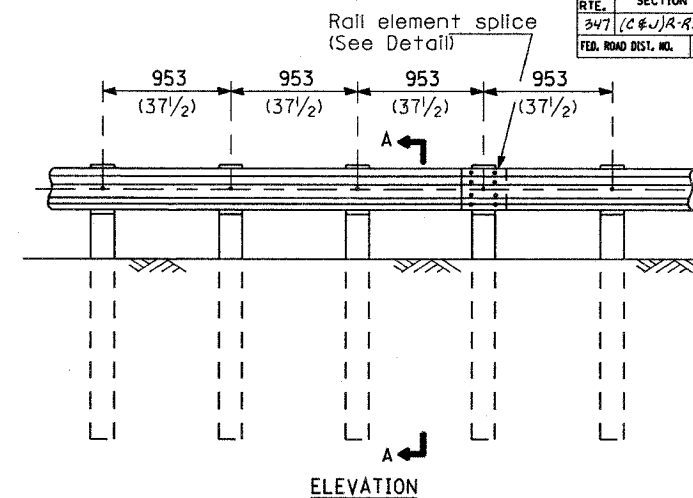

TYPE B

953 (37 1/2) Closed post spacing

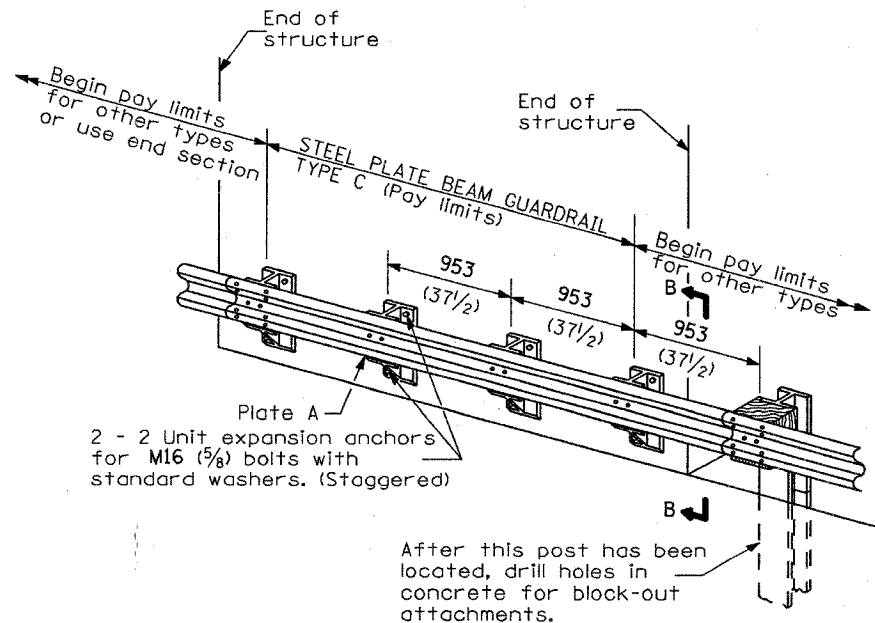

TYPE C

953 (37 1/2) Block-out spacing

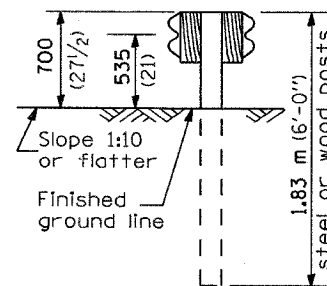

SECTION C-C

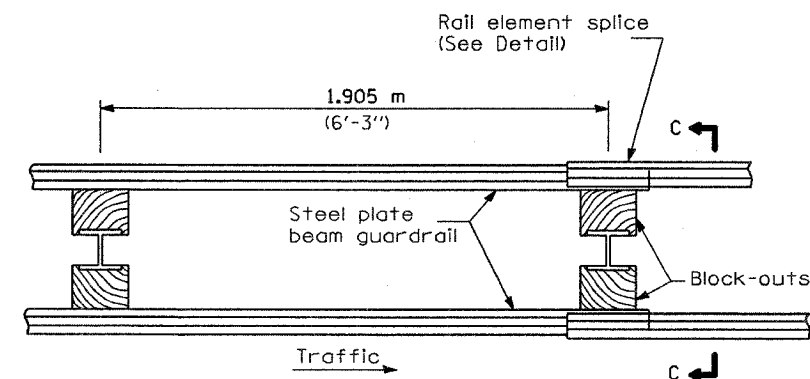

PLAN

TYPE D

Double steel plate beam guardrail
1.905 m (6'-3") typical post spacing

GENERAL NOTES

All slope ratios are expressed as units of vertical displacement to units of horizontal displacement (V:H).

All dimensions are in millimeters (inches) unless otherwise shown.

The existing steel posts may be drilled to match the bolt pattern shown herein for the wood block-out, or a new steel post shall be provided.

This detail is applicable to the guardrail system used prior to January 1, 2007. For details on the Midwest Guardrail System, see Standard 630001.

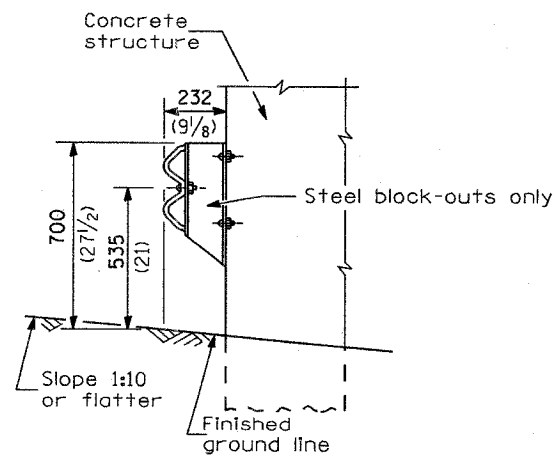

SECTION B-B

**REMOVE AND REERECT
STEEL PLATE BEAM GUARDRAIL**

(Sheet 1 of 4)

DETAIL