

ROUTE NO.	SECTION	COUNTY	TOTAL SHEETS	SHEET NO.
533	119R-2B	McHenry	64	18
FED. ROAD DIST.	ILLINOIS	FED. AID PROJECT-		

SHEET NO. 4 OF
21 SHEETS

Contract #62336

When "A" is 3'-6" or less, the temporary concrete barrier shall be anchored to the new slab according to Detail I or Detail II. No anchorage is required when "A" is greater than 3'-6".

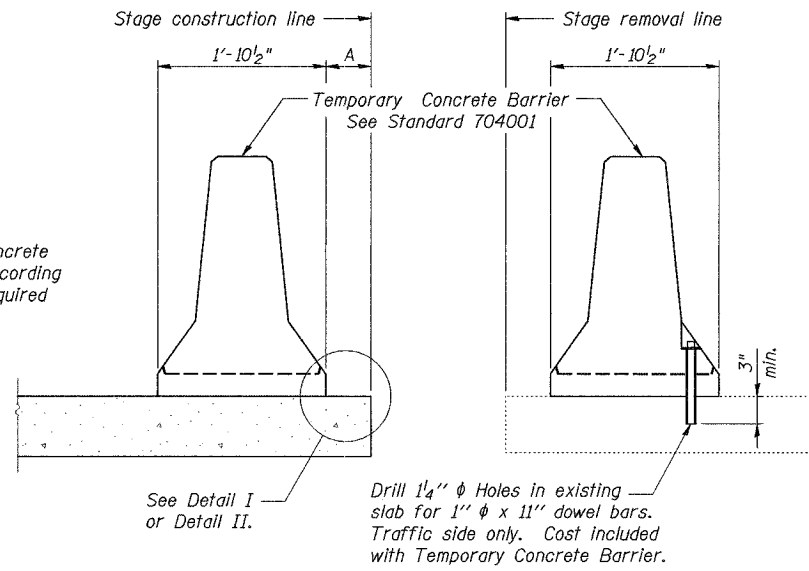

NEW SLAB

EXISTING SLAB

SECTIONS THRU SLAB

NOTES

Detail I - With Bar Splicer or Couplers:

Connect one (1) 1"x7"x10" steel \bar{P} to the top layer of couplers with 2-5/8" ϕ bolts screwed to coupler at approximate \bar{C} of each barrier panel.

Detail II - With Extended Reinforcement Bars:

Connect one (1) 1"x7"x10" steel \bar{P} to the concrete slab with 2-5/8" ϕ Expansion Anchors or cast in place inserts spaced between the top layer of reinforcement at approximate \bar{C} of each barrier panel.

Cost of anchorage is included with Temporary Concrete Barrier. The 1" x 7" x 10" plate shall not be removed until stage II construction forms and all reinforcement bars are in place and the concrete is ready to be placed.

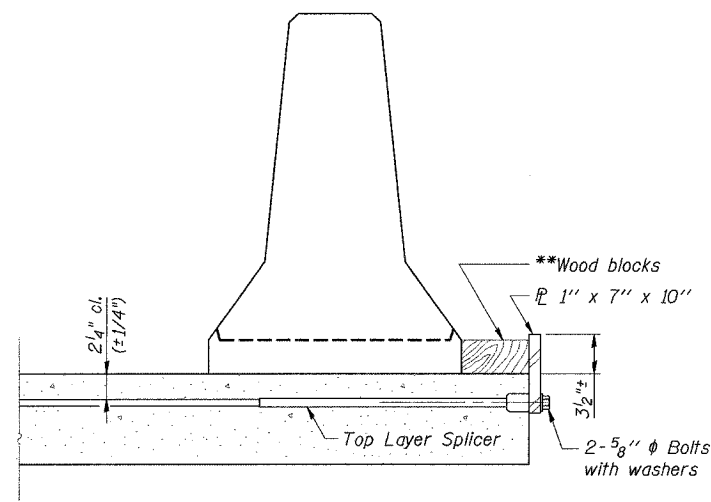

DETAIL I

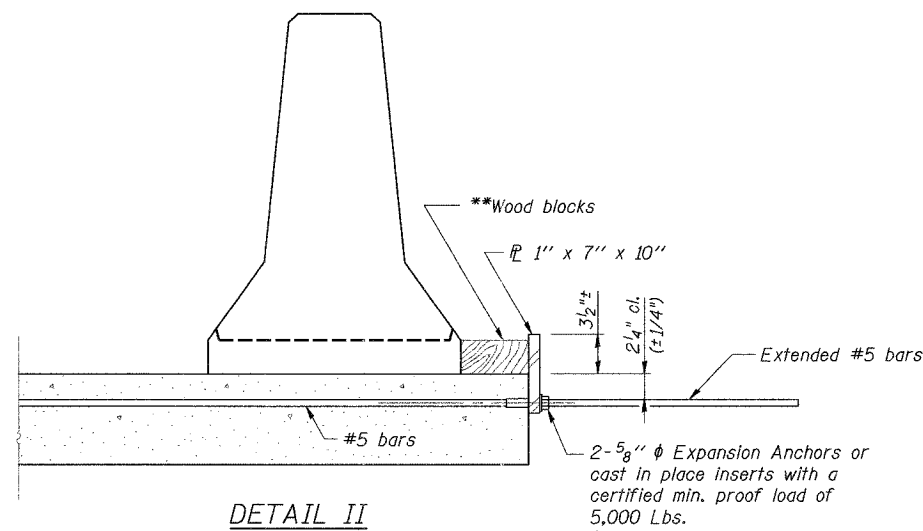

DETAIL II

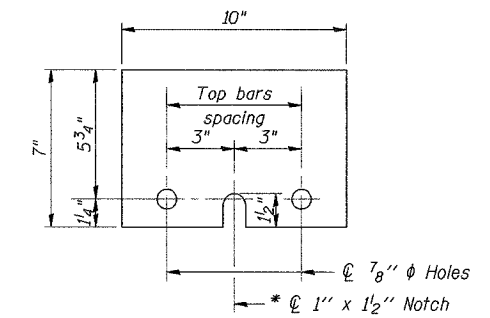

STEEL RETAINER \bar{P} 1" x 7" x 10"

* Required only with Detail II

** Wood blocks may be omitted when required to provide minimum stage traffic lane width. When the wood blocks are omitted, the concrete barrier shall be in direct contact with the steel retainer plate.

DESIGNED	J.Z.
CHECKED	S.D.H.
DRAWN	M.S.M.
CHECKED	S.D.H.

R-27 11-1-06

TEMPORARY CONCRETE BARRIER
FOR STAGE CONSTRUCTION
IL Route 176 over the Kishwaukee River
F.A.P. RTE 533, SECTION 119R-2B
McHENRY COUNTY
STATION 10+00.00
S.N. 056-0078

DATE: 10-05-07

GRAEF, ANHALT, SCHLOEMER & ASSOCIATES INC
CHICAGO ILLINOIS