

STATE OF ILLINOIS
DEPARTMENT OF TRANSPORTATION

ROUTE NO.	SECTION	COUNTY	SHEET	SHEET	SHEET NO. 9
FAP 308	104-BY-1BR1D	CARROLL	40	21	9 SHEETS
FED. ROAD DIST. NO. 7	ILLINOIS	FED. AID PROJECT	Contract #64D14		

When "A" is 3'-6" or less, the temporary concrete barrier shall be anchored to the new slab according to Detail I or Detail II. No anchorage is required when "A" is greater than 3'-6".

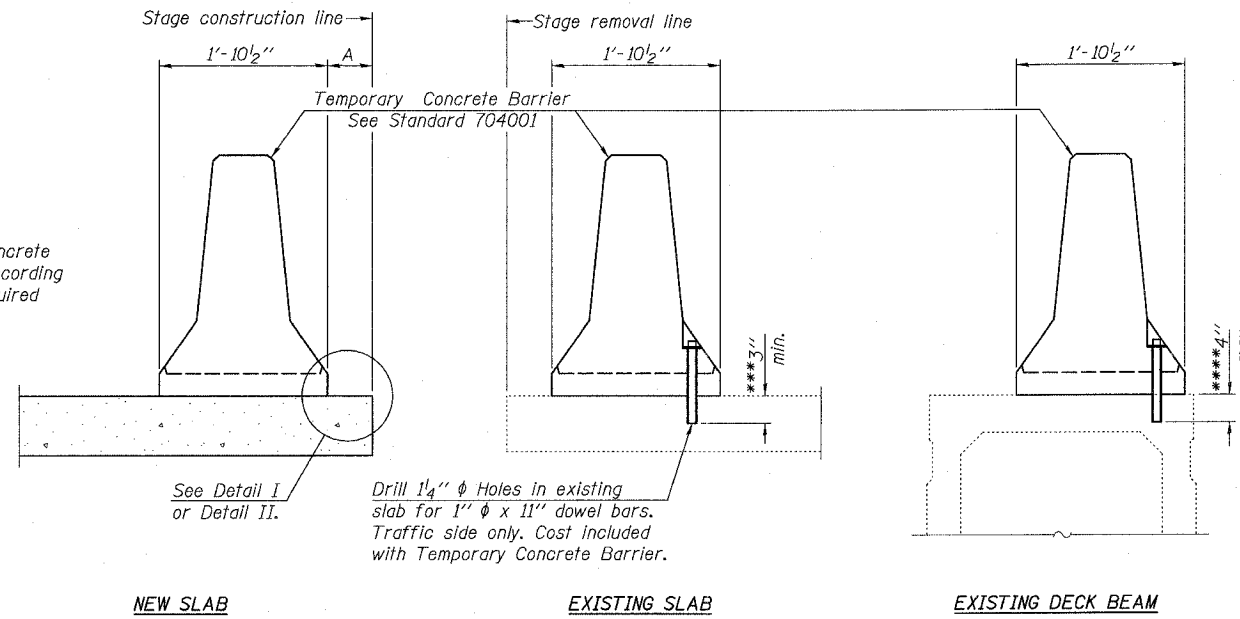

Drill 1/4" ϕ Holes in existing slab for 1" ϕ x 11" dowel bars. Traffic side only. Cost included with Temporary Concrete Barrier.

SECTIONS THRU SLAB OR DECK BEAM

- NOTES**
- Detail I - With Bar Splicer or Couplers:
Connect one (1) 1"x7"x10" steel \bar{P} to the top layer of couplers with 2-5/8" ϕ bolts screwed to coupler at approximate \bar{C} of each barrier panel.
- Detail II - With Extended Reinforcement Bars:
Connect one (1) 1"x7"x10" steel \bar{P} to the concrete slab or concrete wearing surface with 2-5/8" ϕ Expansion Anchors or cast in place inserts spaced between the top layer of reinforcement at approximate \bar{C} of each barrier panel.
- Cost of anchorage is included with Temporary Concrete Barrier. The 1" x 7" x 10" plate shall not be removed until stage II construction forms and all reinforcement bars are in place and the concrete is ready to be placed.

- ***Dimension shown is minimum required embedment into concrete. If hot-mix asphalt wearing surface is present, minimum embedment shall be in addition to wearing surface depth.
- ****If existing deck beam is to remain in place after stage construction, embedment shall only be into wearing surface and not into existing deck beam concrete.

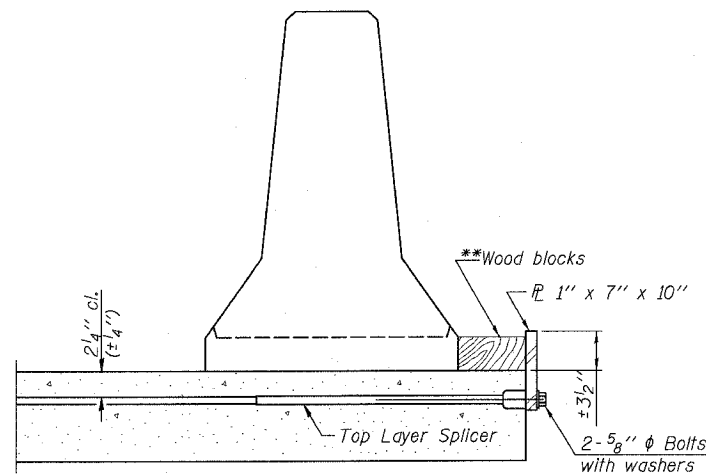

DETAIL I

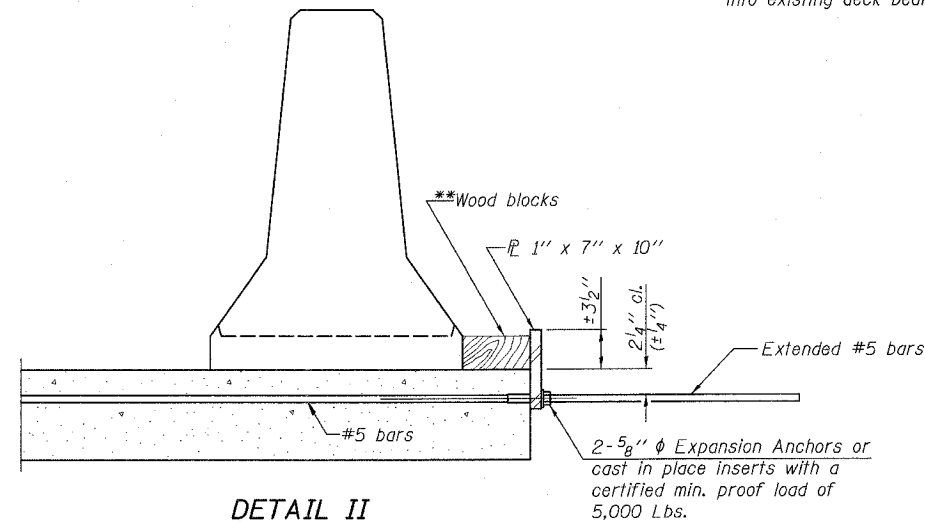

DETAIL II

**Wood blocks may be omitted when required to provide minimum stage traffic lane width. When the wood blocks are omitted, the concrete barrier shall be in direct contact with the steel retainer plate.

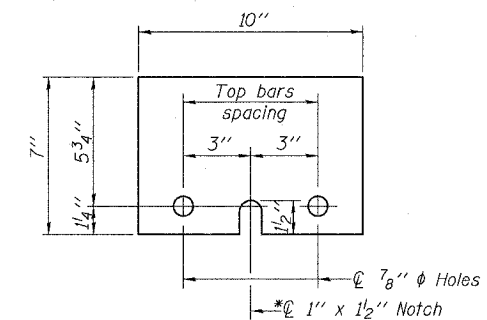

STEEL RETAINER \bar{P} 1" x 7" x 10"

* Required only with Detail II

DESIGNED	GPM
CHECKED	BRT
DRAWN	GPM
CHECKED	BRT

R-27

9-3-07

ILLINOIS DEPARTMENT OF TRANSPORTATION
**TEMPORARY CONCRETE BARRIER
FOR STAGED CONSTRUCTION**

IL-84 OVER A DRAINAGE DITCH
FAP ROUTE 308 SECTION (104-BY-1BR)D
CARROLL COUNTY
STATION 566+38
STRUCTURE NO. 008-0016

SCALE: NONE
DATE 10/10/07