

WITNESS MARKER FOR PERMANENT SURVEY MARKERS, TYPE II

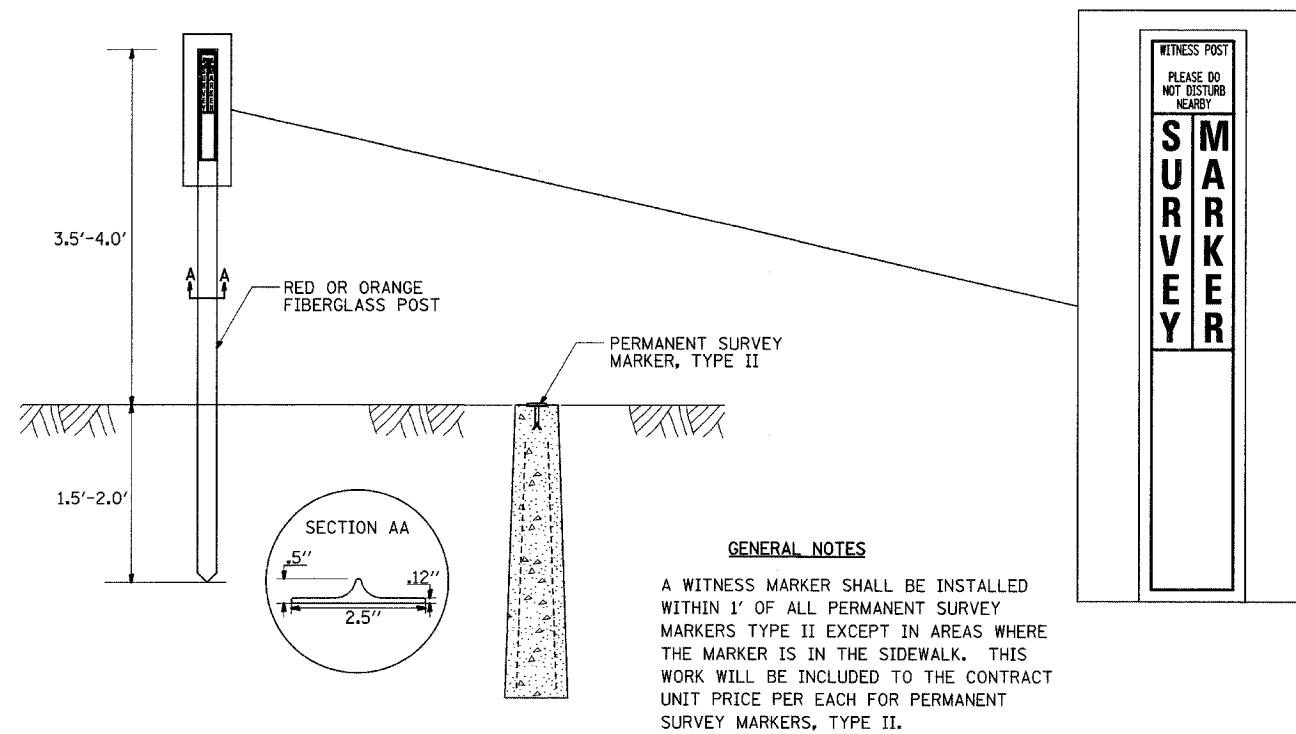

PERMANENT SURVEY MARKERS, TYPE II

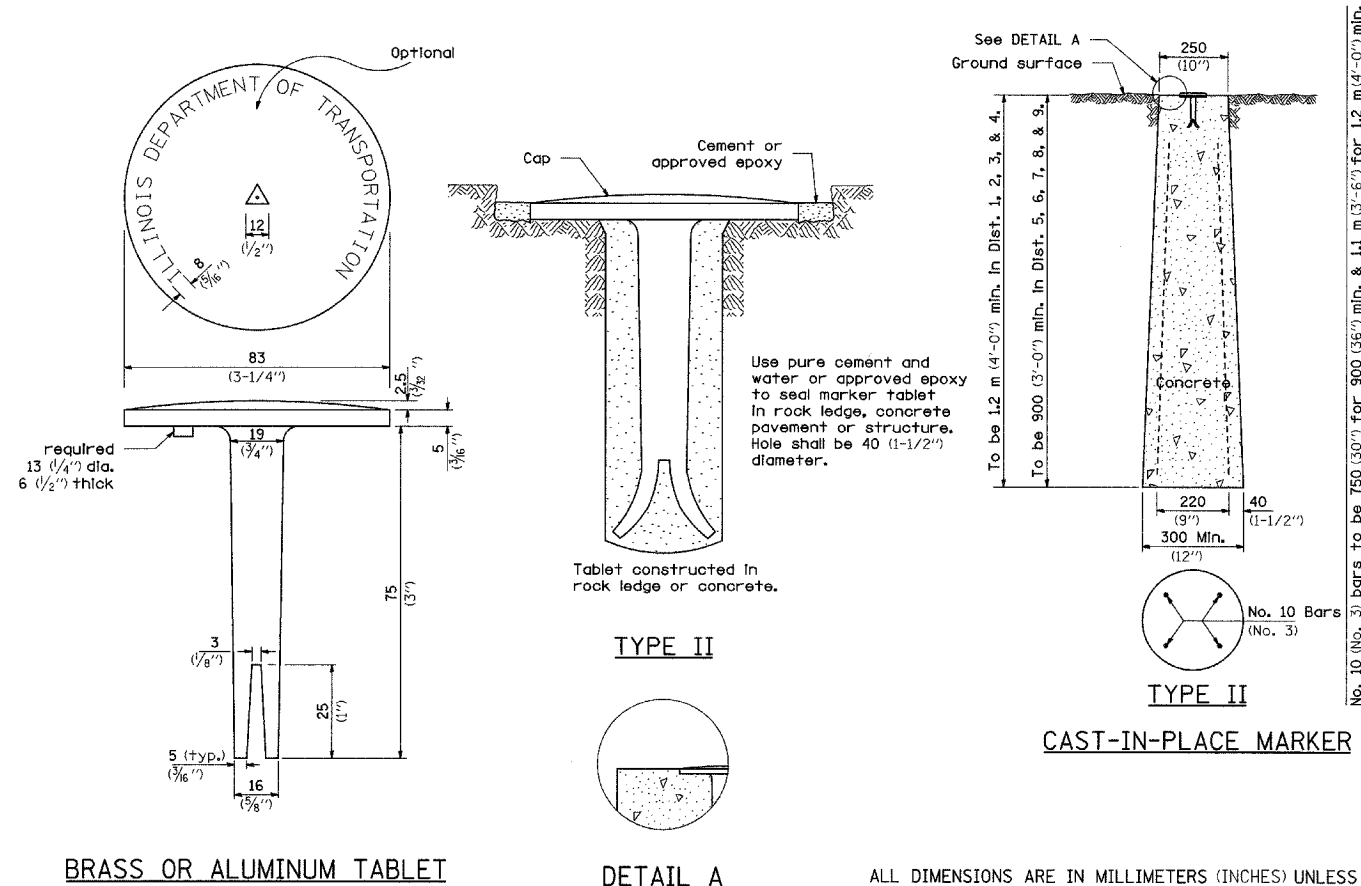

No. 10 (No. 3) bars to be 750 (30") for 900 (36") min. & 1.1 m (3'-6") for 1.2 m (4'-0") min.

ALL DIMENSIONS ARE IN MILLIMETERS (INCHES) UNLESS OTHERWISE NOTED.

REVISED - 6-26-06

REVISED -	REGION 2 / DISTRICT 2 STANDARD	F.A.P. RTE.	SECTION	COUNTY	TOTAL SHEETS	SHEET NO.	
REVISED -		646	(5BR-1)D	CARROLL	52	29	
REVISED -		SCALE: 50.0000' / 1" SHEET NO. 29 OF 52 SHEETS STA.			TO STA.		FED. ROAD DIST. NO. ILLINOIS FED. AID PROJECT
REVISED -		CONTRACT NO. 64D29					
REVISED -							