

F.A.P. RTE.	SECTION	COUNTY	TOTAL SHEETS	SHEET NO.
642	11T	CARROLL	79	48
STA.		TO STA.		
FED. ROAD DIST. NO.		ILLINOIS	FED. AID PROJECT	

# DROP BOX NO. 3

## RT STA 843+08 (IL 78)

### BILL OF MATERIALS

BAR	NO.	SIZE	LENGTH	WEIGHT (LB)	BAR SHAPE
a	20	#6	15'-1"	453.10	—
b	36	#6	5'-1"	274.87	—
h	16	#6	5'-1"	122.16	—
h <sub>1</sub>	8	#6	15'-1"	181.24	—
L	18	#5	5'-6"	103.26	—
L <sub>1</sub>	28	#5	4'-10"	141.15	—
L <sub>2</sub>	2	#5	5'-5"	11.30	—
L <sub>3</sub>	4	#5	6'-3"	26.08	—
s	18	#4	3'-7"	43.09	—
v	28	#5	3'-1"	90.05	—
v <sub>1</sub>	18	#5	4'-3"	79.79	—
PIPE HANDRAIL				FOOT	39.0
CLASS "SI" CONCRETE				CU YD	5.07
REINFORCEMENT BARS				LB	1526.08

### GENERAL NOTES:

REINFORCEMENT BARS SHALL CONFORM TO THE REQUIREMENTS OF AASHTO M-31 OR M-53, GRADE 60.

SEE PLAN AND PROFILE SHEET FOR MORE INFORMATION.  
SEE CROSS SECTION SHEET FOR MORE INFORMATION.

ALL HANDRAIL DIMENSIONS SHALL BE VERIFIED BY CONTRACTOR PRIOR TO FABRICATION OF PIPE HANDRAIL, BASED UPON FINAL LOCATION OF MOUNTING BOLTS.

HANDRAIL SHALL CONFORM TO SECTION 510 WITH THE EXCEPTION THAT ALL PIPE AND CONNECTIONS SHALL BE WELDED GALVANIZED OR ALUMINUM ACCORDING TO ARTICLE 1006.27, 1006.30, OR 1006.34.

THE DIAMETER OF THE GRIPPING SURFACE OF THE HANDRAIL SHALL BE 1-1/4" TO 1-1/2"

ENDS OF HANDRAIL SHALL BE ROUNDED.

HAND & SAFETY RAILS SHALL NOT ROTATE WITHIN THEIR FITTINGS.

GRIPPING SURFACES SHALL BE UNINTERRUPTED BY NEWEL POSTS, OTHER CONSTRUCTION ELEMENTS, OR OBSTRUCTIONS.

SEE PIPE HANDRAIL DETAIL SHEET FOR MORE INFORMATION.

THIS WORK SHALL BE DONE ACCORDING TO THE APPLICABLE PORTION OF 503, 508, 540, AND 542 OF THE STANDARD SPECIFICATIONS.

CLASS "SI" CONCRETE SHALL BE USED. EXPOSED EDGES SHALL BE BEVELED 3/4".

J BOLTS OR REBAR SPLICERS SHALL BE USED TO CONNECT THE PRECAST SECTIONS TO THE CAST-IN-PLACE SECTIONS.

THE CONTRACT UNIT PRICE "CU YD" FOR CLASS "SI" CONCRETE SHALL INCLUDE THE EXPANSION BOLTS, J BOLTS, REBAR SPLICERS, ANCHOR BOLTS, BOLTS, NUTS, WASHERS, STEEL PLATES, EARTH EXCAVATION WHERE REQUIRED, AND NECESSARY GRADING TO FIT THE INLET AS SHOWN IN THE CROSS SECTIONS OR TO THE SLOPE.

THE CONTRACT UNIT PRICE "FOOT" FOR PIPE HANDRAIL SHALL INCLUDE THE PIPE, ANCHOR RODS, ANCHOR BOLTS, BOLTS, NUTS, WASHERS, AND STEEL BASE PLATES.

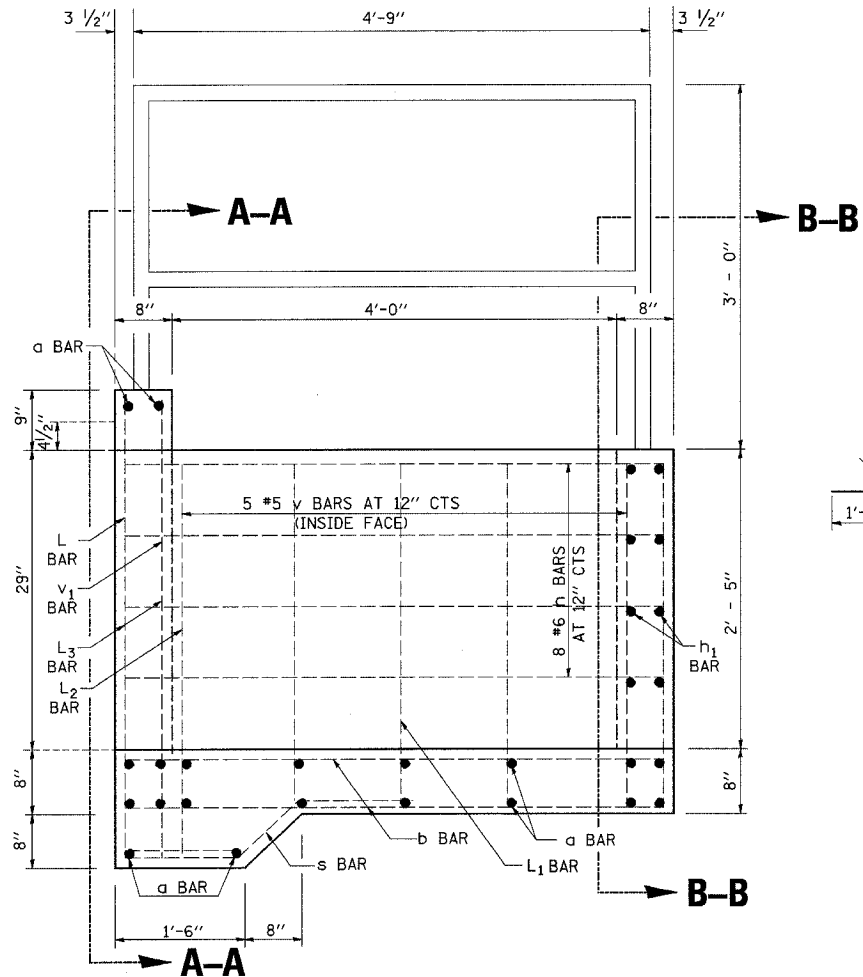

**PROFILE**

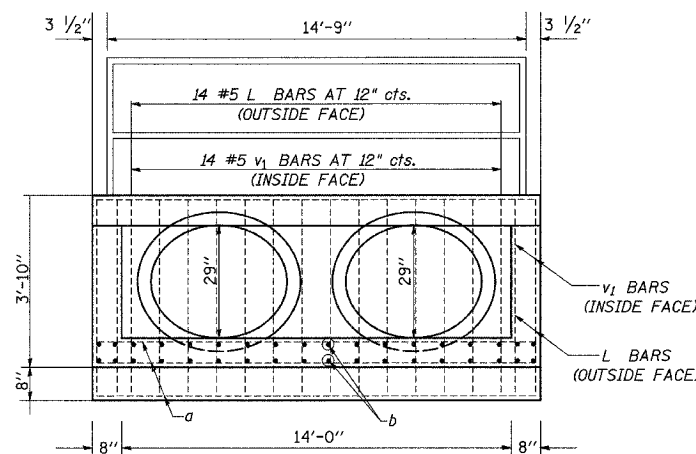
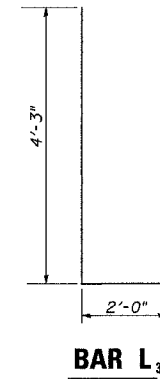
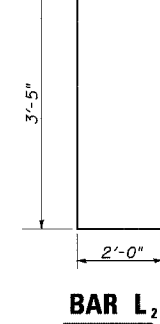
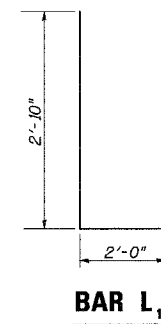
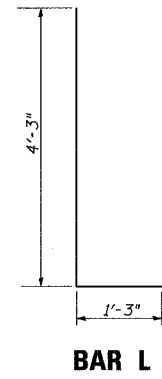
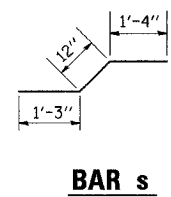

**SECTION A-A**

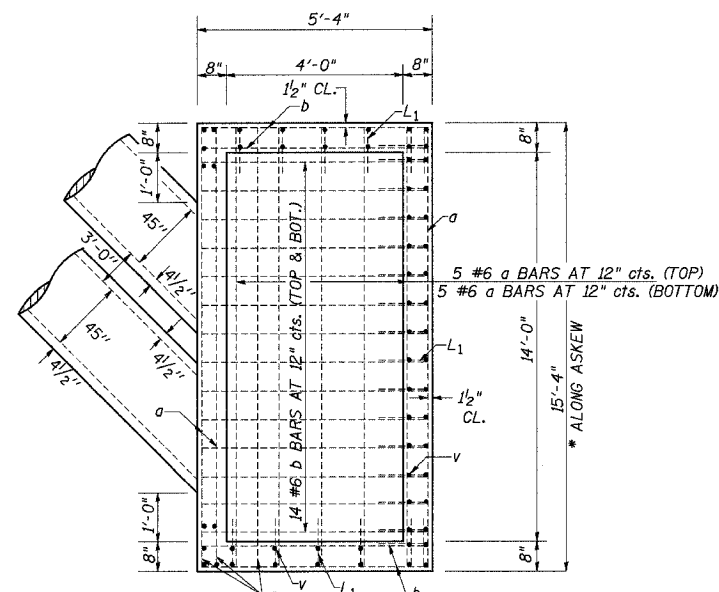

**PLAN**

1/2" DIA. STEEL HAND RAIL (STYLE & MANUFACTURER TO BE DETERMINED BY ENGINEER & CONTRACTOR)

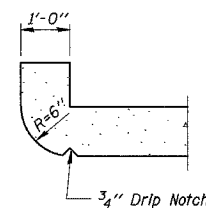

**SECTION THRU HEADWALL**

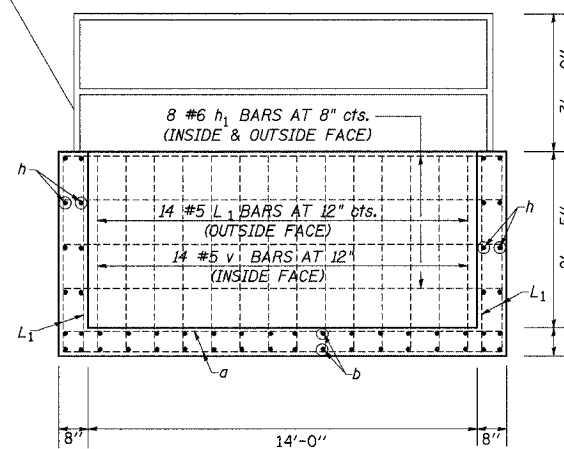

**SECTION B-B**

PLOT DATE = Wed Dec 19 15:22:53 2007  
FILE NAME = c:\pwworkspace\15222581\dwg\64d82\11t.dgn  
USER NAME = c:\admin