

F.A.I. RTE.	SECTION	COUNTY	TOTAL SHEETS	SHEET NO.
80	(50-5) HBK-2	LASALLE	331	160
STA.		TO STA.		
FED. ROAD DIST. NO.		ILLINOIS FED. AID PROJECT		

GENERAL NOTES:

1. THE CURB AND GUTTER CONFIGURATION SHALL BE M- 4.06
2. SEE STD. 606001 & AND 606301 FOR ADDITIONAL DETAILS.
3. ALL MATERIALS, LABOR, AND EQUIPMENT REQUIRED TO COMPLETE THE WORK SHALL BE INCLUDED IN THE COST OF ISLAND PAVEMENT (SPECIAL) PER SQUARE YARD.

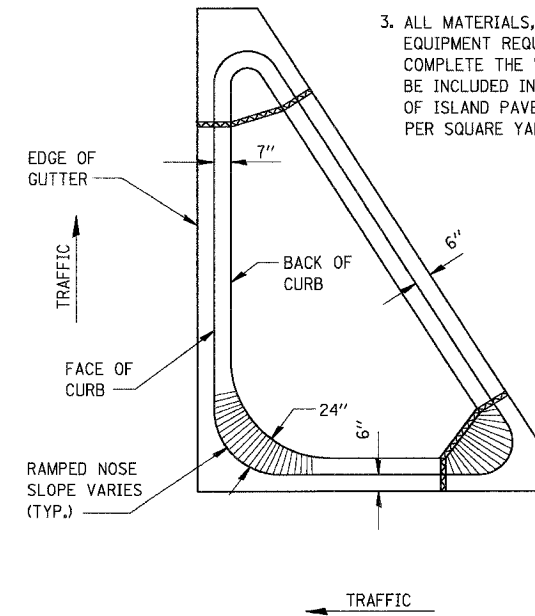

606-1

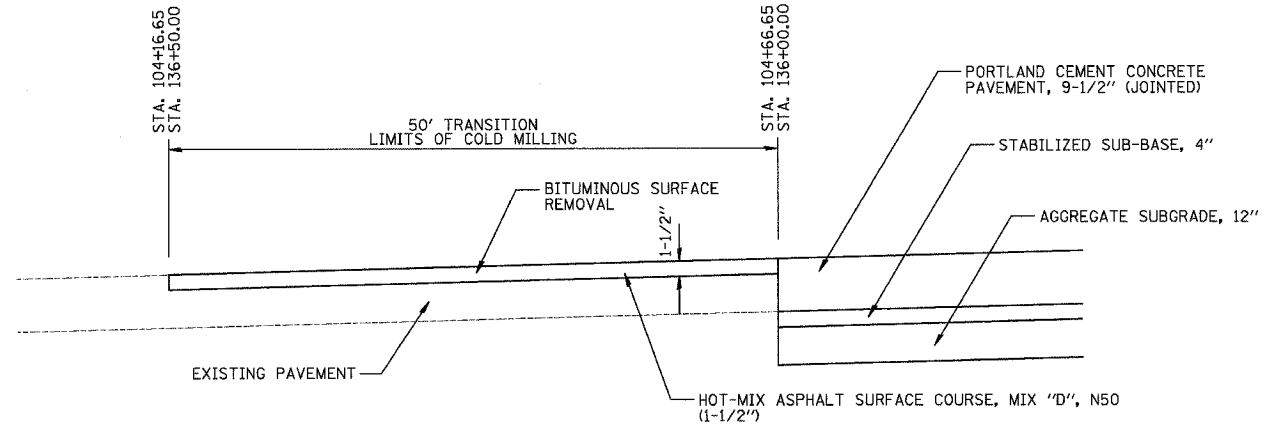

PAVEMENT INLAY DETAIL
MARSEILLES ROAD
NTS

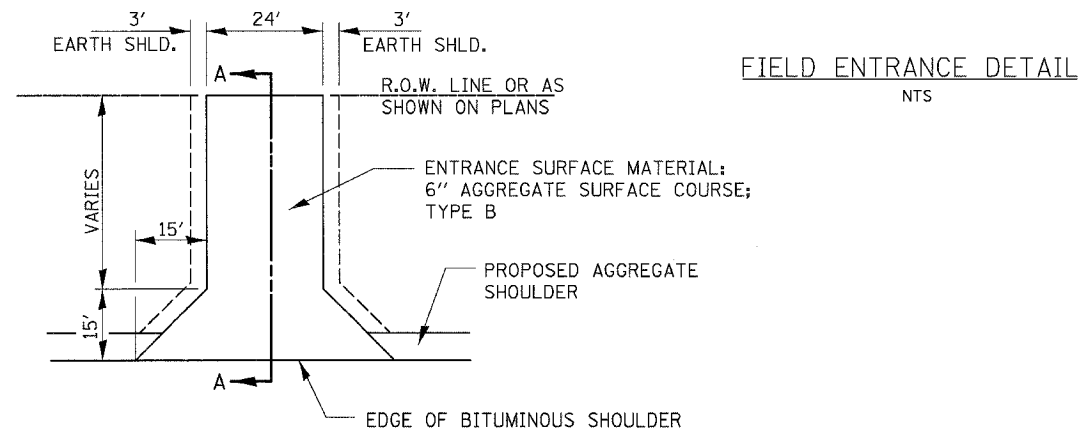

FIELD ENTRANCE DETAIL
NTS

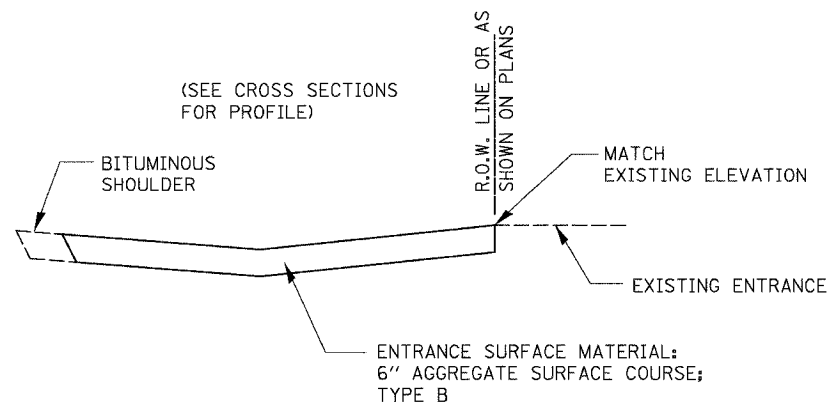

402-1

REVISIONS	
NAME	DATE

ILLINOIS DEPARTMENT OF TRANSPORTATION

PAVEMENT INLAY DETAIL

SCALE: NONE
DATE: 11/02/07

DRAWN BY: KM
CHECKED BY: SE

