

| F.A.P. RTE. | SECTION | COUNTY | TOTAL SHEETS | SHEET NO. |
|---------------------|----------|----------|--------------|-----------|
| 796 | (105)1-1 | FORD | 25 | 14 |
| FED. ROAD DIST. NO. | | ILLINOIS | | |

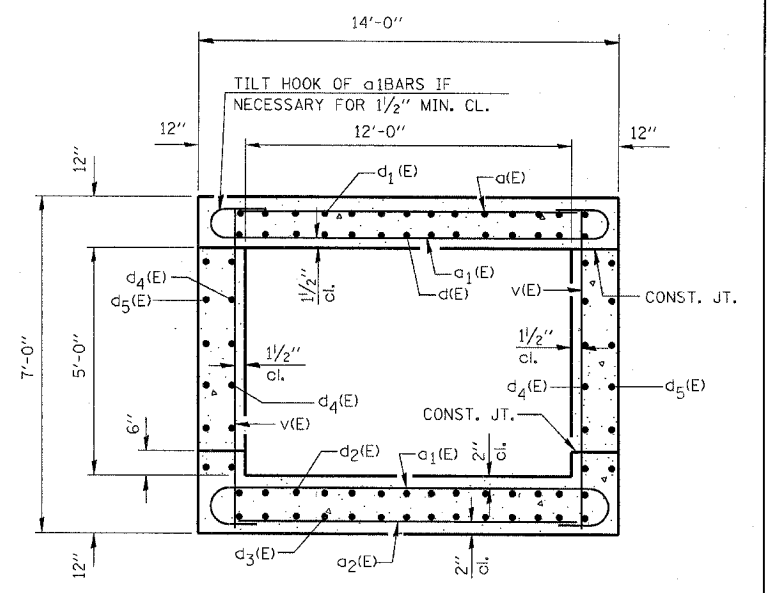

END ELEVATION

| BILL OF MATERIALS - EACH END | | | | |
|----------------------------------|-----|------|--------------|-------|
| BAR | NO. | SIZE | LENGTH (FT.) | SHAPE |
| $a(E)$ | 4 | #5 | 12'-3" | — |
| $a(E)$ | 22 | #8 | 14'-6" | U |
| $a(E)$ | 3 | #4 | 12'-3" | — |
| $d(E)$ | 14 | #8 | 6'-9" | ┌ |
| $d(E)$ | 14 | #5 | 6'-9" | └ |
| $d(E)$ | 14 | #5 | 7'-9" | ┌ |
| $d(E)$ | 14 | #5 | 7'-9" | └ |
| $d(E)$ | 12 | #5 | 8'-2" | ┌ |
| $d(E)$ | 12 | #5 | 8'-2" | └ |
| $h(E)$ | 20 | #5 | 14'-2" | — |
| $h(E)$ | 24 | #5 | 6'-0" | — |
| $v(E)$ | 14 | #4 | 6'-9" | — |
| $v_1(E)$ | 28 | #5 | 7'-3" | — |
| CONCRETE BOX CULVERT | | | CU YD | 13.2 |
| REINFORCEMENT BARS, EPOXY COATED | | | POUND | 2276 |

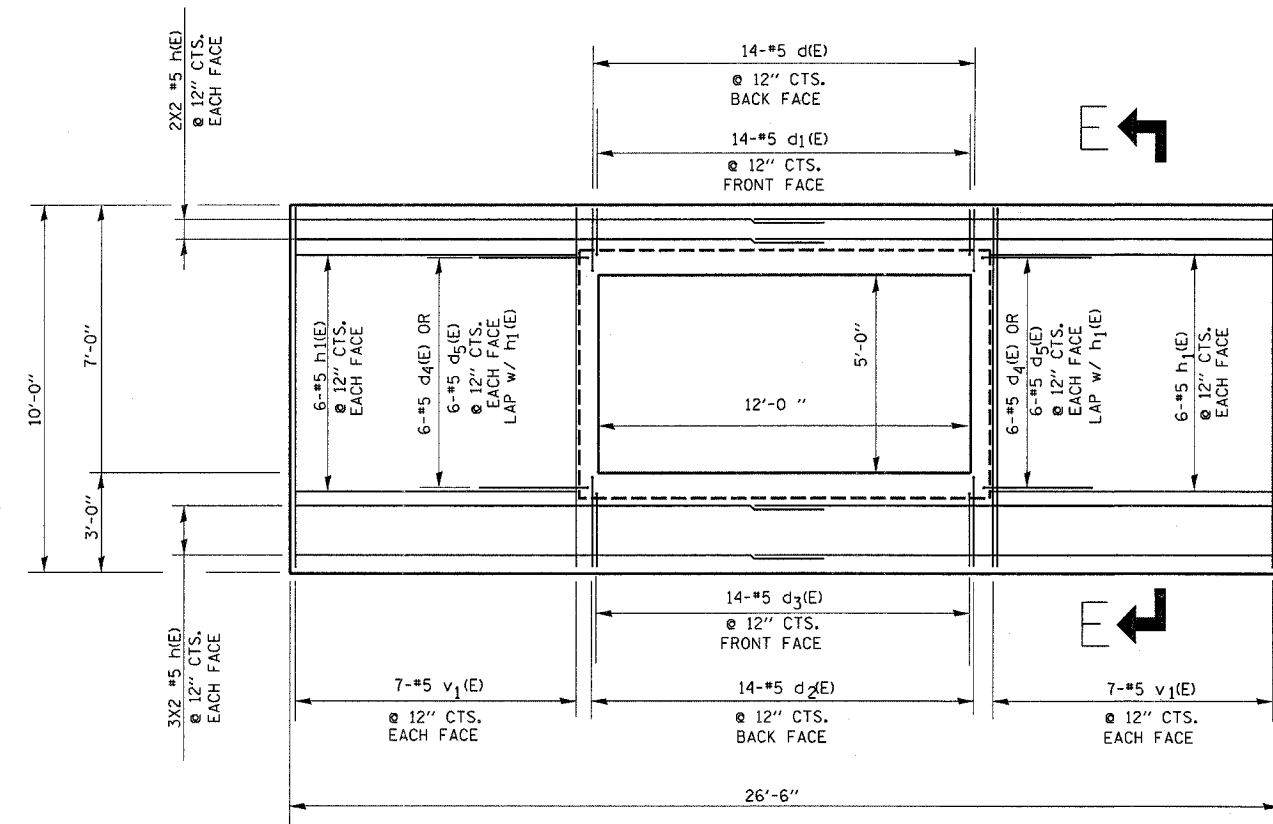
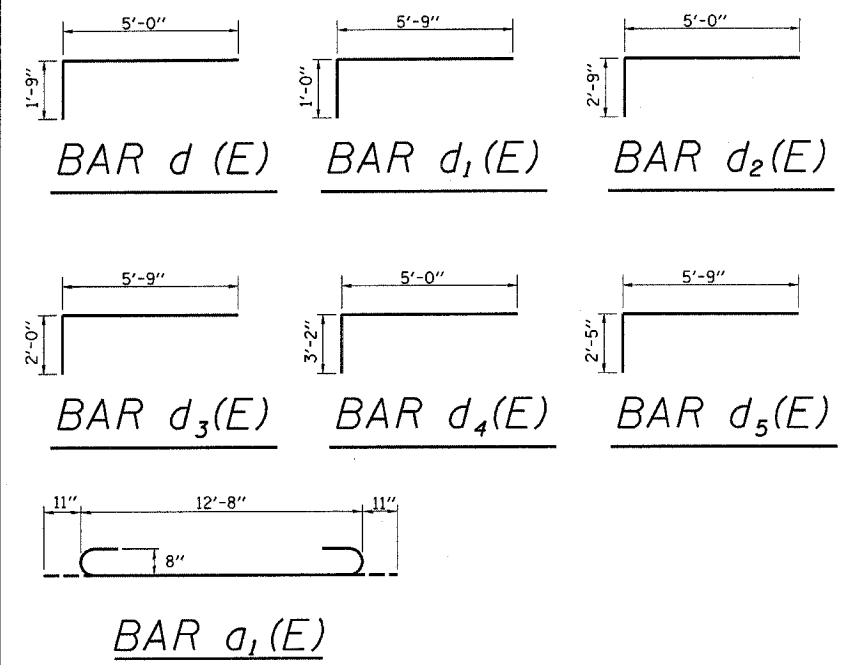
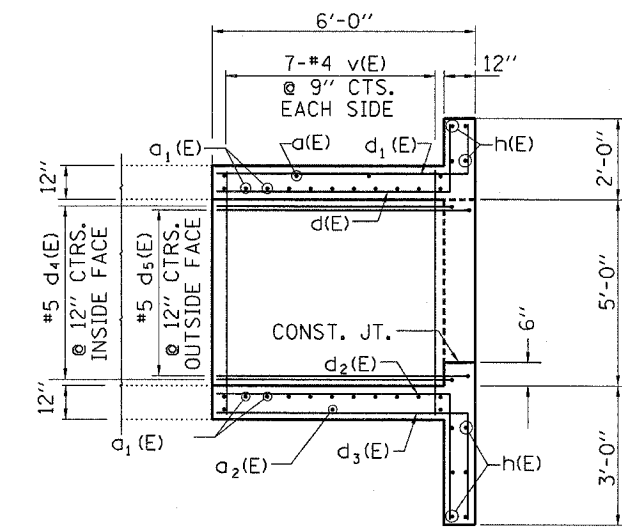
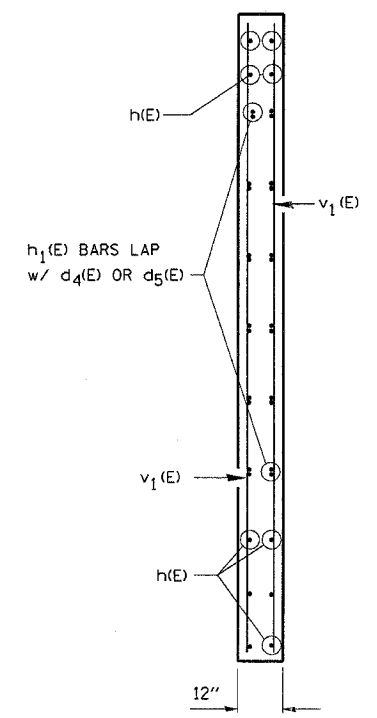
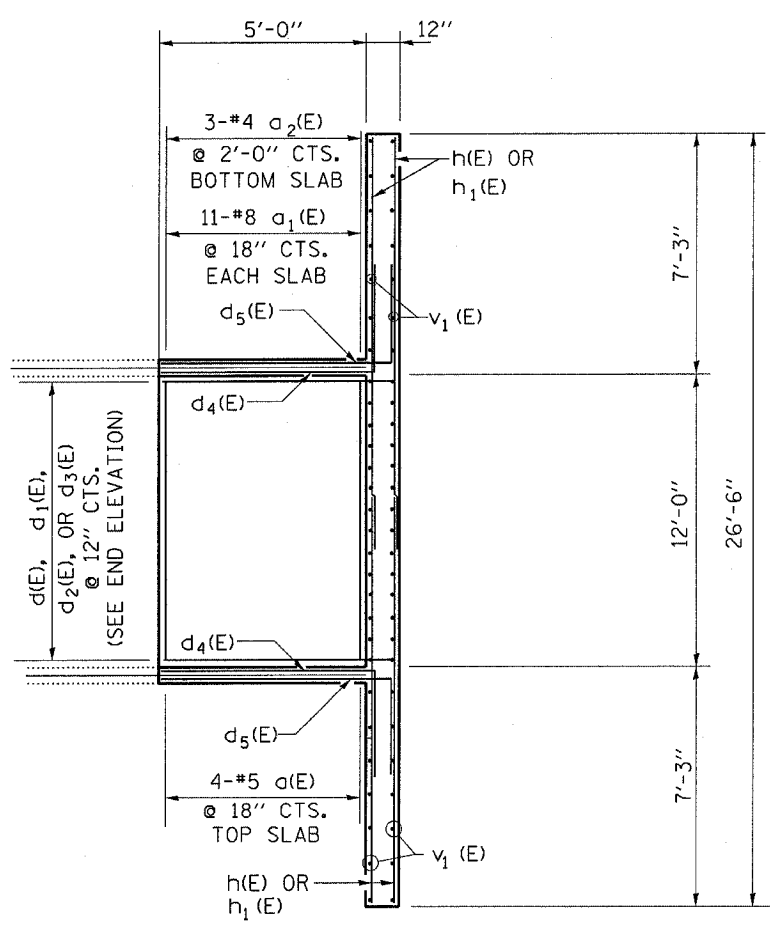

SIDE ELEVATION

PLAN DOWNSTREAM

SECTION E-E

NOTE: DOWNSTREAM END SHOWN, UPSTREAM SYMMETRICAL BY 180°

| REVISIONS | |
|-----------|------|
| NAME | DATE |
| | |
| | |
| | |
| | |
| | |

ILLINOIS DEPARTMENT OF TRANSPORTATION
BOX CULVERT END SECTIONS
 FAP 796 (IL 115) SECTION (105)1-1
 FORD COUNTY
 STA. 1499+59.60
 S.N. 027-2550

Oct 22, 2007 - 08:06:17 AM
 c:\pro\sect\ep03206\box_culverts.dgn