

F.A.P. RTE.	SECTION	COUNTY	TOTAL SHEETS	SHEET NO.
808		DOUGLAS	42	28
STA.		TO STA.		
FED. ROAD DIST. NO.	ILLINOIS	FED. AID PROJECT		

(12,Y-15D)10RS-2

DETAIL OF SIDEROAD RETURN WITH 1275N
LT. STATION 173+20.00 / RT. STATION 173+30.00

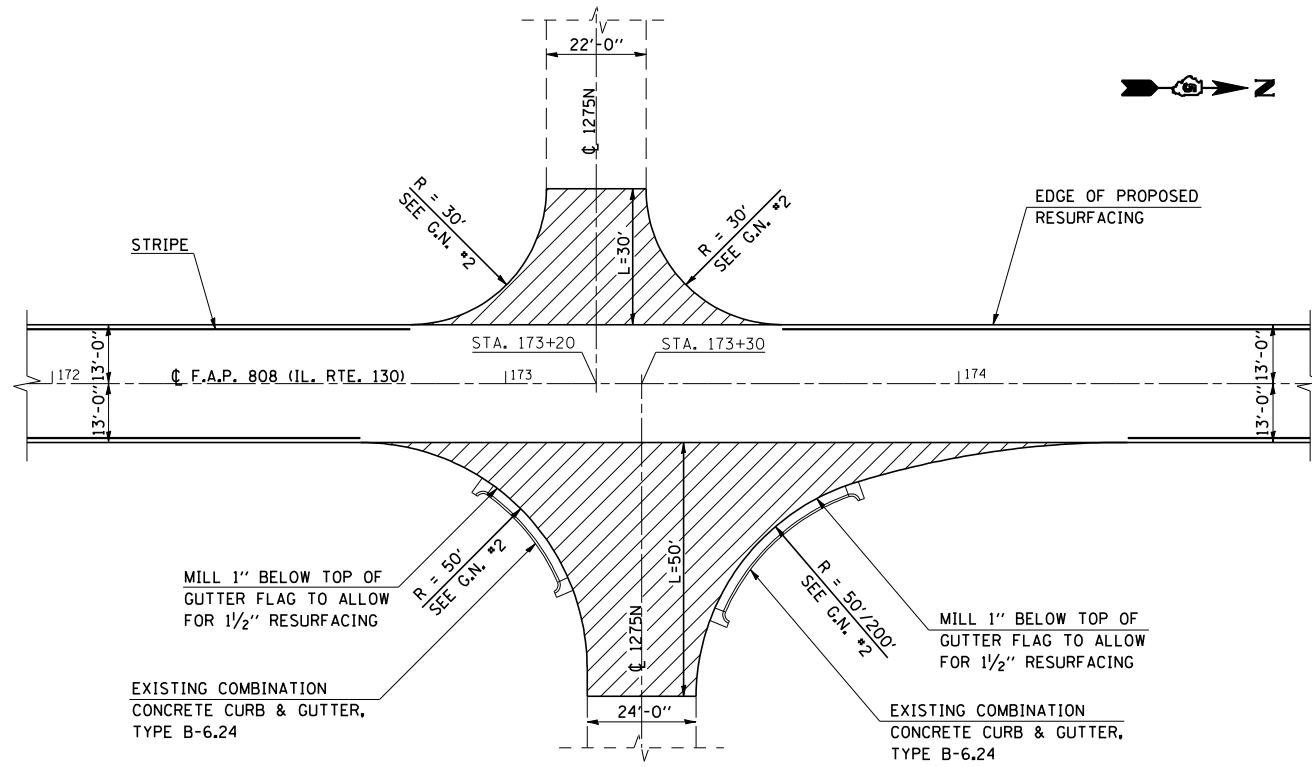

PLAN

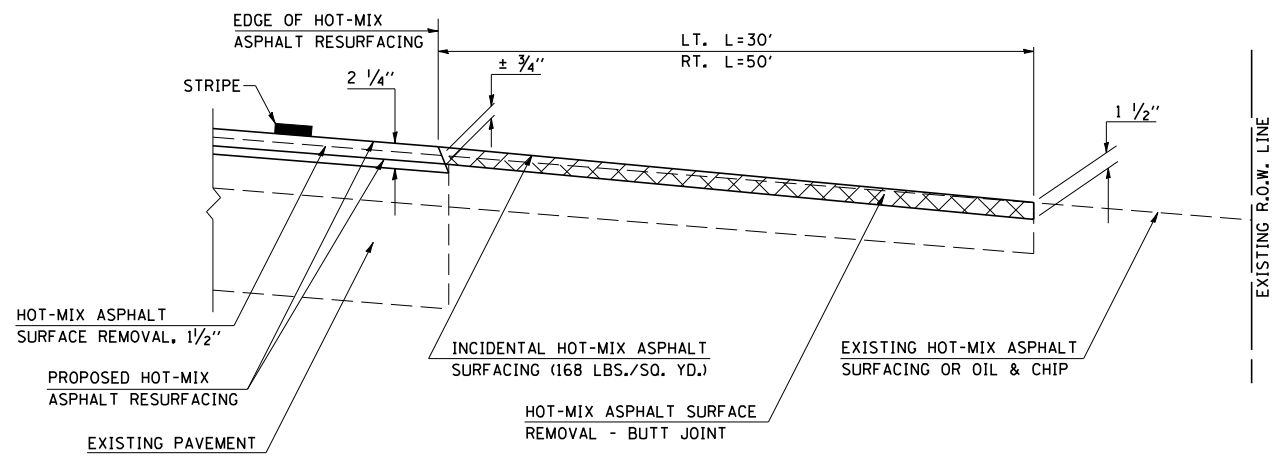

PROFILE

GENERAL NOTES

1. THE EXISTING SURFACE SHALL BE PREPARED IN ACCORDANCE WITH SECTION 408 OF THE STANDARD SPECIFICATIONS.
2. THE INCIDENTAL HOT-MIX ASPHALT SURFACING IS INTENDED TO RESURFACE THE EXISTING SIDEROADS IN THEIR ENTIRETY. THE EXISTING SIDEROADS SHOULD BE RESURFACED TO MAINTAIN THEIR CURRENT RADII AND SHALL BE RESURFACED TO THE BACK OF RADIUS.

PLOT DATE = 10/18/2007
 FILE NAME = c:\projects\0506902 (v8)\70275det\tdls.dgn
 USER = collierdw