

**M.W.R.D.G.C. GENERAL NOTES**

**DRAINAGE AND UTILITIES NOTES**

- THE MWRDGC LOCAL SEWER SYSTEMS SECTION FIELD OFFICE MUST BE NOTIFIED AT LEAST TWO (2) WORKING DAYS PRIOR TO THE COMMENCEMENT OF WORK AT (708) 588-4055.
- ELEVATION DATUM IS U.S.G.S.
- ALL FLOOR DRAINS SHALL DISCHARGE TO THE SANITARY SEWER SYSTEM.
- ALL DOWNSPOUTS AND FOOTING DRAINS SHALL DISCHARGE INTO THE STORM SEWER SYSTEM.
- ALL PVC STORM, COMBINED, AND SANITARY SEWER PIPE JOINTS SHALL CONFORM TO ASTM D-3139, AND THE PIPE SHALL CONFORM TO ASTM D-2241. ALL PVC SEWER PIPE SHALL BE SDR 26. ALL RCCP SEWER TO MEET ASTM C-76 AND JOINTS SHALL CONFORM TO ASTM C-443.
- ALL SANITARY SEWER CONSTRUCTION, AND ALSO STORM SEWER CONSTRUCTION IN COMBINED SEWER AREAS, REQUIRES STONE BEDDING 1/2" TO 1" IN SIZE, WITH A MINIMUM THICKNESS EQUAL TO 1/4 THE OUTSIDE DIAMETER OF THE SEWER PIPE, BUT NOT LESS THAN FOUR INCHES (4") NOR MORE THAN EIGHT INCHES (8"). MATERIAL SHALL BE CA-11 OR CA-13 AND SHALL BE EXTENDED AT LEAST 12" ABOVE THE TOP OF THE PIPE WHEN USING PVC PIPE.
- "BAND SEAL" OR SIMILAR FLEXIBLE-TYPE COUPLINGS SHALL BE USED IN THE CONNECTION OF SEWER PIPE OF DISSIMILAR MATERIALS.
- WHEN CONNECTING TO AN EXISTING SEWER MAIN BY MEANS OTHER THAN AN EXISTING WYE, TEE, OR AN EXISTING MANHOLE, ONE OF THE FOLLOWING METHODS SHALL BE USED:
  - CIRCULAR SAW-CUT OF SEWER MAIN BY MECHANICAL CORING MACHINE, AND PROPER INSTALLATION OF HUB-WYE SADDLE OR HUB-TEE SADDLE, IN ACCORDANCE WITH THE MANUFACTURER'S RECOMMENDATIONS.
  - REMOVE AN ENTIRE SECTION OF PIPE (BREAKING ONLY THE TOP OF ONE BELL) AND REPLACE WITH A WYE OR TEE BRANCH SECTION. AFTER THE WYE OR TEE BRANCH IS INSERTED, CONCRETE SHALL BE PLACED OVER THE BROKEN AREA TO A MINIMUM THICKNESS OF 4" AND TO A DIMENSION OF 8" IN ALL DIRECTIONS.
  - USING PIPE CUTTER, NEATLY AND ACCURATELY CUT OUT DESIRED LENGTH OF PIPE FOR INSERTION OF PROPER FITTING. USE "BAND SEAL" OR SIMILAR COUPLINGS TO HOLD IT FIRMLY IN PLACE. FOLLOW MANUFACTURER'S RECOMMENDATIONS FOR THE INSTALLATION.
- WHEREVER A SANITARY/COMBINED SEWER CROSSES UNDER A WATER MAIN, THE MINIMUM VERTICAL DISTANCE FROM THE TOP OF THE SEWER TO THE BOTTOM OF THE WATER MAIN SHALL BE 18 INCHES. FURTHERMORE, A MINIMUM HORIZONTAL DISTANCE OF 10 FEET BETWEEN SANITARY/ COMBINED SEWERS AND WATER MAINS SHALL BE MAINTAINED UNLESS: THE SEWER IS LAID IN A SEPARATE TRENCH, KEEPING A MINIMUM 18" VERTICAL SEPARATION; OR THE SEWER IS LAID IN THE SAME TRENCH WITH THE WATER MAIN LOCATED AT THE OPPOSITE SIDE ON BENCH OF UNDISTURBED EARTH, KEEPING A MINIMUM 18" VERTICAL SEPARATION. IF EITHER THE VERTICAL OR HORIZONTAL DISTANCES DESCRIBED ABOVE CANNOT BE MAINTAINED, OR THE SEWER CROSSES ABOVE THE WATER MAIN, THE SEWER SHALL BE CONSTRUCTED TO WATER MAIN STANDARDS.
- ALL EXISTING SEPTIC SYSTEMS SHALL BE ABANDONED. ABANDONED TANKS SHALL BE FILLED WITH GRANULAR MATERIAL OR REMOVED.
- ALL SANITARY MANHOLES, (AND STORM MANHOLES IN COMBINED SEWER AREAS), SHALL HAVE A MINIMUM INSIDE DIAMETER OF 48 INCHES, AND SHALL BE CAST IN PLACE OR PRE-CAST REINFORCED CONCRETE.
- ALL ABANDONED SANITARY SEWERS SHALL BE PLUGGED AT BOTH ENDS WITH A MINIMUM OF TWO (2) FOOT LONG, NON-SHRINK CONCRETE/MORTAR PLUG.
- ALL INLET AND OUTLET PIPES OF SANITARY SEWER MANHOLES AND OTHER UNDERGROUND STRUCTURES (IN COMBINED SEWER AREAS, ALSO INCLUDED ARE ALL COMBINED/STORM SEWER MANHOLES, CATCH BASINS, INLETS, AND UNDERGROUND DETENTION STORAGE STRUCTURES) SHALL BE JOINED WITH WATERTIGHT FLEXIBLE RUBBER CONNECTORS CONFORMING TO ASTM C-443 AND C-923 WITH STAINLESS STEEL BAND.

THE LOCATIONS OF EXISTING DRAINAGE STRUCTURES, STORM SEWERS, COMBINED SEWERS, TELEPHONE LINES, COMMUNICATION LINES, ELECTRIC LINES, GAS MAINS, AND WATER SERVICES ARE APPROXIMATE AND THEIR SPECIFIC LOCATIONS ARE TO BE DETERMINED IN THE FIELD AT NO COMPENSATION TO THE CONTRACTOR.

WHEN EXISTING DRAINAGE FACILITIES ARE DISTURBED, THE CONTRACTOR SHALL PROVIDE AND MAINTAIN TEMPORARY OUTLETS AND CONNECTIONS FOR ALL PRIVATE OR PUBLIC DRAINAGE STRUCTURES OR SEWERS UNTIL PERMANENT CONNECTIONS TO SEWERS ARE BUILT AND IN SERVICE. THIS WORK SHALL NOT BE PAID FOR DIRECTLY, BUT SHALL BE CONSIDERED INCIDENTAL TO THE CONTRACT.

WHEN, DURING CONSTRUCTION OPERATIONS, ANY LOOSE MATERIALS ARE DEPOSITED IN THE FLOW LINES OF GUTTERS OR DRAINAGE STRUCTURES SO THAT THE NATURAL FLOW OF WATER IS OBSTRUCTED, THE OBSTRUCTING MATERIALS SHALL BE REMOVED AT THE CLOSE OF EACH WORK DAY. AT THE CONCLUSION OF THE CONSTRUCTION OPERATIONS, ALL DRAINAGE STRUCTURES ARE TO BE FREE OF ALL DIRT, DEBRIS, AND OBSTRUCTING MATERIALS. THE WORK SPECIFIED ABOVE WILL NOT BE PAID FOR SEPARATELY, BUT SHALL BE CONSIDERED AS INCIDENTAL TO THE CONTRACT.

ALL PROPOSED WATER MAINS SHALL BE INSTALLED IN ACCORDANCE WITH IN THE "STANDARD SPECIFICATIONS FOR WATER AND SEWER MAIN CONSTRUCTION IN ILLINOIS", FIFTH EDITION, DATED 1996, AND ALL REVISIONS THERETO.

THE CONTRACTOR SHALL VERIFY THE TYPE OF ALL WATER MAIN HARDWARE INCLUDING VALVES, FIRE HYDRANTS, VALVE BOXES, CORPORATION STOPS, CURB STOPS, AND WATER SERVICES BOXES WITH THE UTILITY SUPERINTENDENT PRIOR TO ORDERING SUCH MATERIAL.

THE TYPE OF FRAMES AND GRATES REQUIRED FOR ALL CATCH BASINS AND MANHOLES LISTED IN THE SUMMARY OF QUANTITIES MAY BE FOUND ON THE PLANS AT THEIR RESPECTIVE LOCATIONS. WHERE LIDS ARE CALLED FOR ON THE PLANS, THEY SHALL BE IN ACCORDANCE WITH ARTICLE 604.01 OF THE STANDARD SPECIFICATIONS AND THE TERM LID IS USED IN LIEU OF GRATE.

ON ALL IMPROVEMENTS, THE FRAMES AND LIDS OF EXISTING CATCH BASINS, INLETS, MANHOLES, AND VALVE VAULTS WHICH ARE TO BE ABANDONED DUE TO CONSTRUCTION OF THIS IMPROVEMENT ARE TO REMAIN THE PROPERTY OF THE VILLAGE OF RIVER GROVE AND BE SALVAGED. THE CONTRACTOR IS TO DELIVER FRAMES AND LIDS TO THE VILLAGE OF RIVER GROVE PUBLIC WORKS YARD.

ANY COSTS FOR SHEETING OR SHORING REQUIRED FOR THE STORM SEWER INSTALLATION OR OTHER CONSTRUCTION ELEMENTS REQUIRING RELATIVELY DEEP EXCAVATIONS SHALL BE INCLUDED IN THE PARTICULAR PAYMENT ITEM AND NO ADDITIONAL COMPENSATION WILL BE ALLOWED FOR ANY SUPPLEMENTAL WORK ASSOCIATED WITH THE MAINTENANCE OF TRENCH SIDES OR OTHER EXCAVATED AREAS.

UNLESS OTHERWISE SPECIFIED, ABANDONED SEWERS AND DRAINS, AS DESIGNATED BY THE ENGINEER, SHALL BE PLUGGED WITH CLASS "SI" CONCRETE OR BRICK AND SUITABLE MORTAR TO THE SATISFACTION OF THE ENGINEER. THIS WORK SHALL NOT BE PAID FOR SEPARATELY, BUT SHALL BE INCLUDED IN THE PAY ITEMS FOR REMOVING AND/OR FILLING THE VARIOUS TYPES OF STRUCTURES.

SEWER PIPE INSTALLED ON THIS PROJECT SHALL CONFORM TO THE FOLLOWING STANDARD :

TYPE OF PIPE	MATERIAL STANDARD	JOINT STANDARD
POLYVINYLCHLORIDE PIPE, 12"	ASTM D-2241	ASTM D-3139

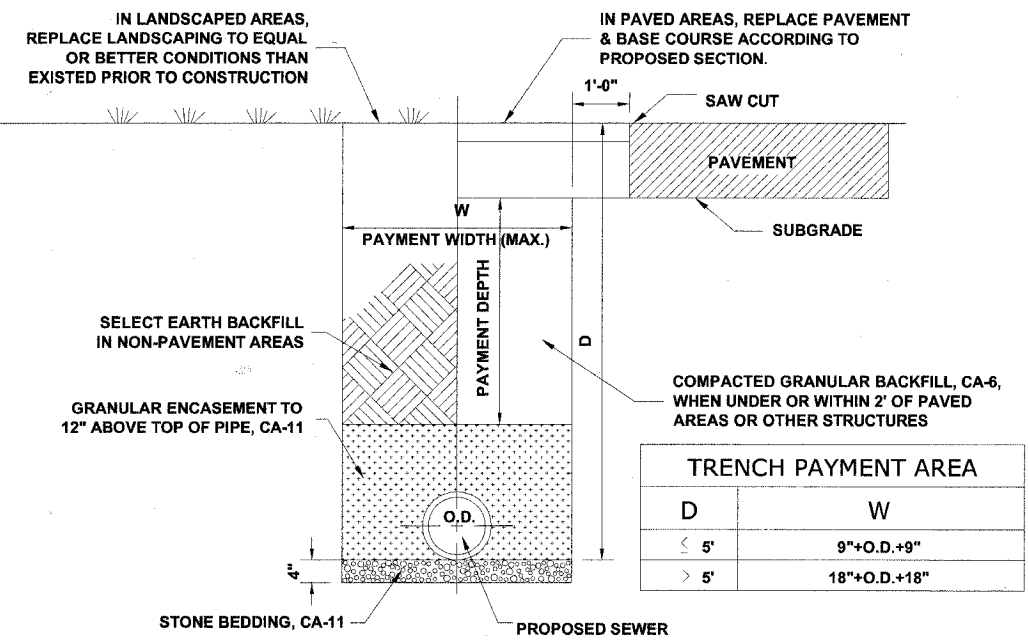

**TYPICAL PVC SEWER TRENCH DETAIL**

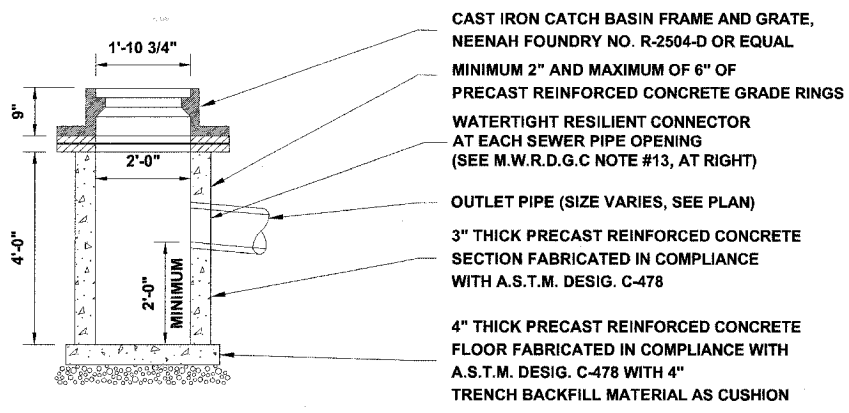

**CATCH BASIN, TYPE "C"**

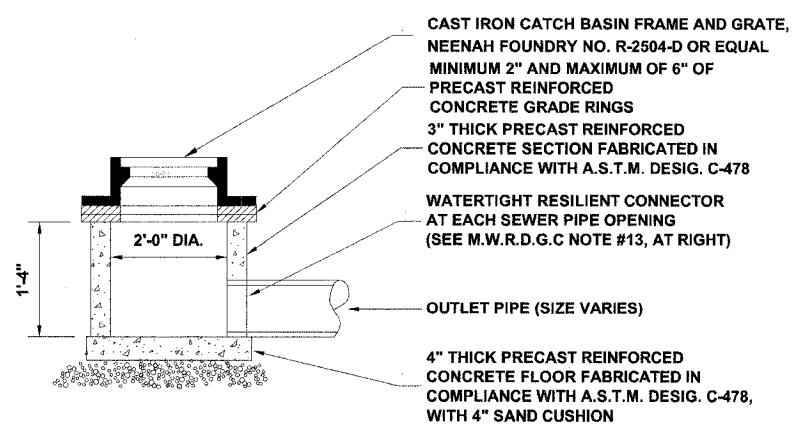

**INLET, TYPE "A"**

Drawing File: W:\projects\76006033 - Grand Ave Streetscape\Boundary Details.dwg Oct 16, 2007 - 2:39pm