

RTE.	SECTION	COUNTY	TOTAL SHEETS	SHEET NO.
I.R. 256	06-11116-00-BR	MACON	14	5
STA. 8+67.32	TO STA. 21+4.18			
FED. ROAD DIST. NO.	ILLINOIS PROJECT	BROS-115463		

CONTRACT NO. 95530

DATE	
BY	
REVISIONS	
1.	
2.	
3.	
4.	
5.	

DATE	
BY	
REVISIONS	
1.	
2.	
3.	
4.	
5.	

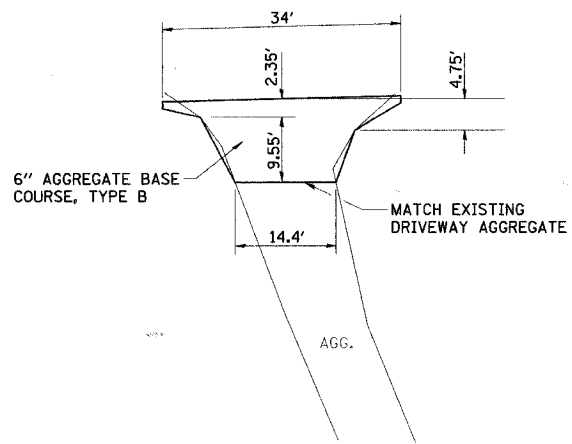

**PRIVATE ENTRANCE DETAIL
STA. 16+82.83**

AGGREGATE BASE COURSE, TYPE B
TOTAL = 10 TONS

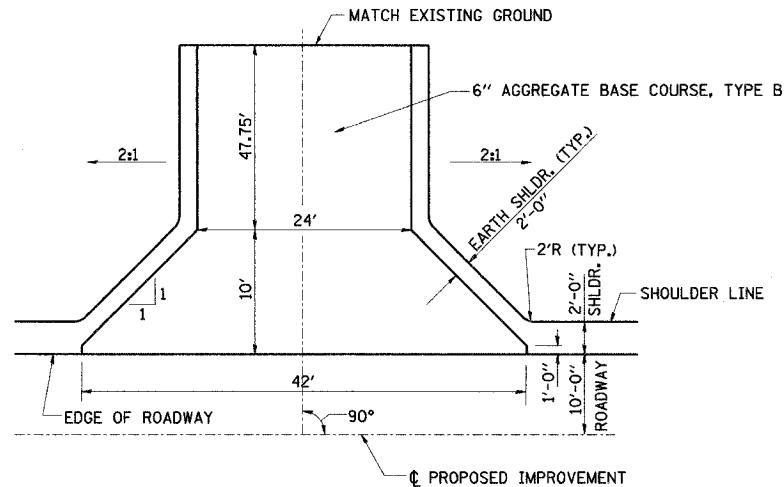

**FIELD ENTRANCE DETAIL
STA. 13+50.00**

AGGREGATE BASE COURSE, TYPE B
TOTAL = 57 TONS

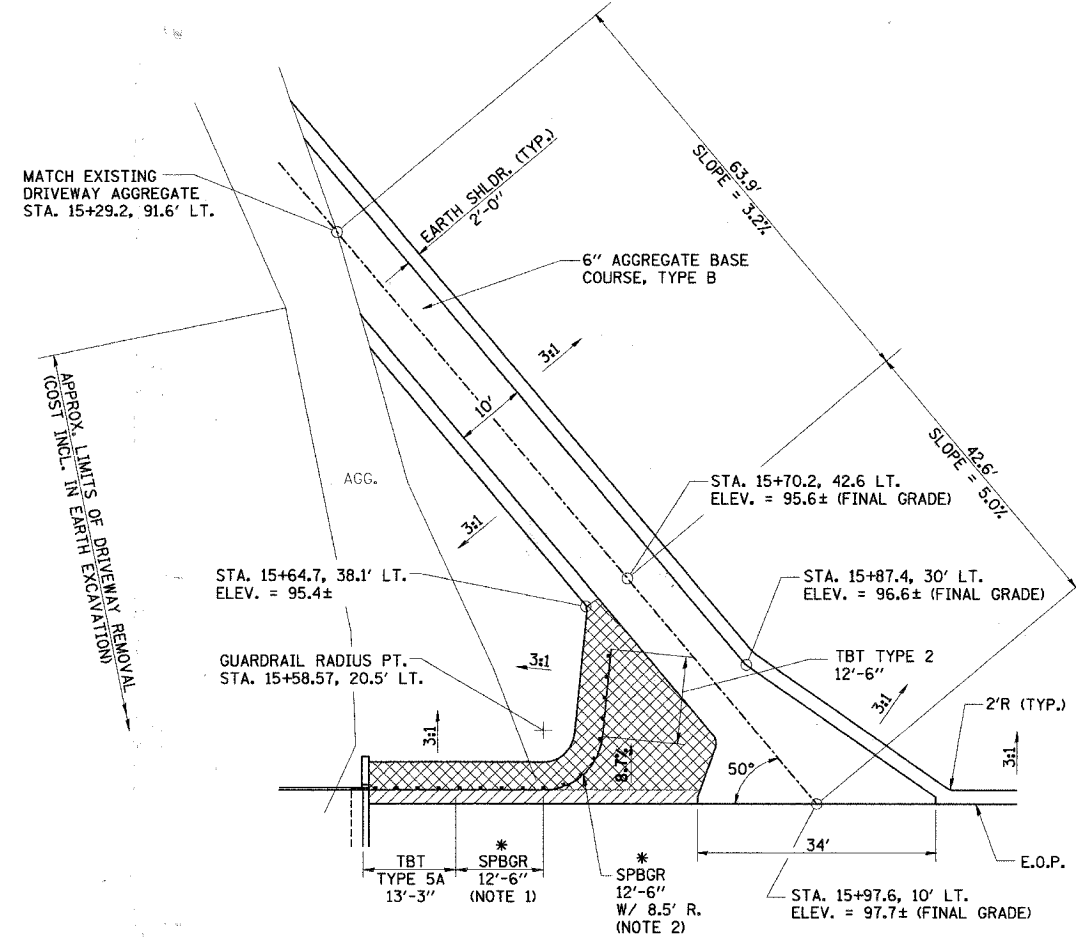

- 2' SHLDR. SLOPED AT 1/2" / FT.
- SLOPED AT 8.7%

* PAY LIMITS OF STEEL PLATE BEAM GUARDRAIL, SHORT RADIUS = 25'-0"

**PRIVATE ENTRANCE DETAIL
STA. 16+06.00**

AGGREGATE BASE COURSE, TYPE B
TOTAL = 50 TONS

NOTES:

- CONSTRUCT ACCORDING TO STANDARD 631011-04 FOR TRAFFIC BARRIER TERMINAL TYPE 2, EXCEPT DELETE END SECTION AND SPLICE INTO RADIUS GUARDRAIL. THE RAIL HEIGHT OF THE TRAFFIC BARRIER TERMINAL TYPE 2'S WILL BE 27".
- FOR THE 8'-6" RADIUS, THE RAIL IS NOT BOLTED TO THE POST LOCATED AT THE MIDPOINT OF THE CURVE.

Revised 12-20-07

ENTRANCE DETAILS