

FIS ROUTE	IDOT SECTION	COUNTY
1857	04-00071-00-BR	MONROE
FEDERAL AID PROJECT	ILLINOIS	
IDOT JOB NO.	BR-RS-1857(121)	
IDOT CONTRACT NO.	97323	

THOUVENOT, WADE & MOERCHEN, INC.
ENGINEERS ♦ SURVEYORS ♦ PLANNERS



- CORPORATE OFFICE**
4940 OLD COLLINSVILLE RD.
SWANSEA, ILLINOIS 62226
TEL (618) 624-4488
FAX (618) 624-6688
corp@twm-inc.com
- EDWARDSVILLE OFFICE**
1015B CENTURY DRIVE
EDWARDSVILLE, ILLINOIS 62025
TEL (618) 656-4040
FAX (618) 656-4343
edwardsville@twm-inc.com
- ST. LOUIS OFFICE**
1001 CRAIG ROAD, SUITE 260
ST. LOUIS, MISSOURI 63146
TEL (314) 236-5052
FAX (314) 872-2194
stlouis@twm-inc.com
- WATERLOO OFFICE**
113 SOUTH MAIN STREET
WATERLOO, ILLINOIS 62298
TEL (618) 939-5050
FAX (618) 939-3938
waterloo@twm-inc.com

PROFESSIONAL REGISTRATIONS	LICENSE NO.
ILLINOIS PROFESSIONAL DESIGN FIRM	184-00120
PROFESSIONAL ENGINEERING CORP.	62-03370
PROFESSIONAL STRUCTURAL ENGR. CORP.	81-005202
ILLINOIS PROF. LAND SURVEYING CORP.	048-00029
MISSOURI PROFESSIONAL ENGR. CORP.	NC 001528
MISSOURI LAND SURVEYING CORP.	NC 000346

SEAL

FINAL

Signature: _____
Signature Date: _____
Expiration Date: _____

STATEMENT OF RESPONSIBILITY
I hereby confirm that the document herein to be authenticated by my seal is restricted to this sheet, and I hereby disclaim any responsibility for all other drawings, specifications, estimates, reports or other documents or instruments relating to or intended to be utilized for any other part of the architectural, engineering or survey project.

DETAIL OF FIELD ENTRANCES (10' AGGREGATE APRON) W/ BITUMINOUS SHOULDERS

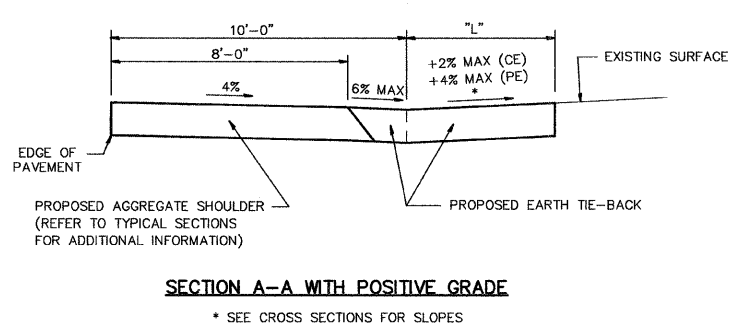
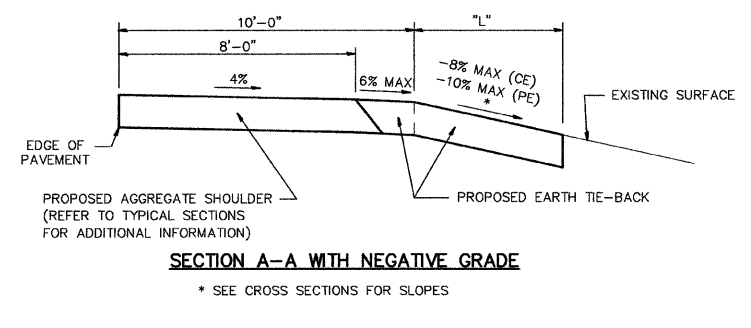
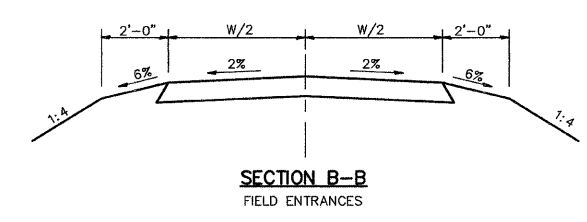
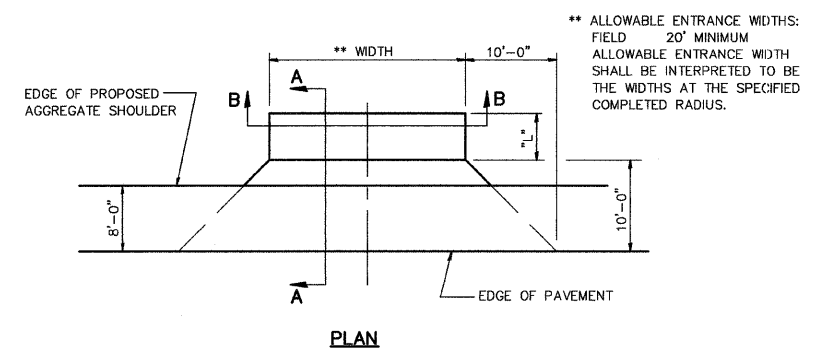

DETAIL OF BUTT-JOINTS/FEATHERED EDGES

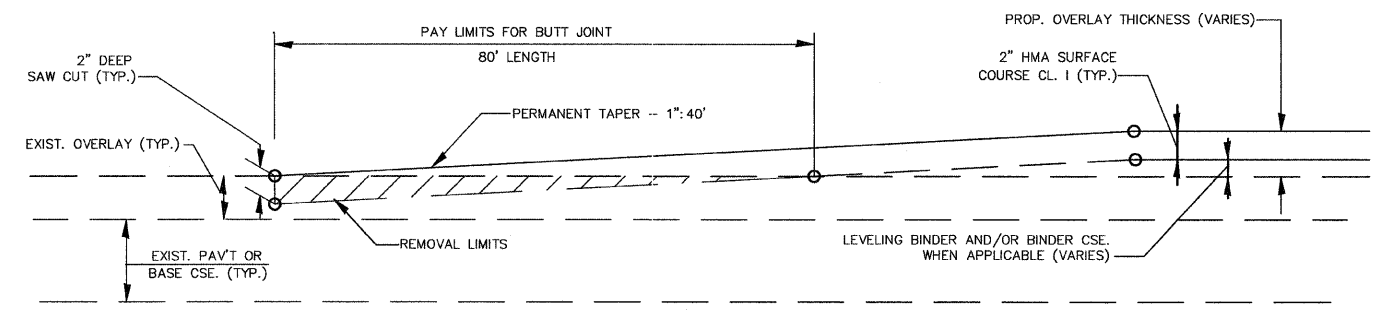

DETAIL OF TEMPORARY RAMP

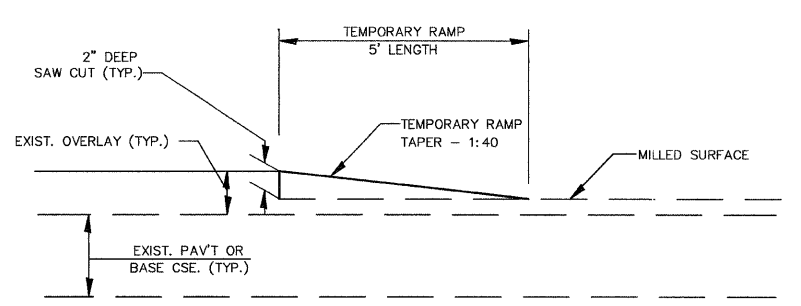

GENERAL NOTES

1. THE WORK SHALL BE DONE ACCORDING TO ARTICLE 406.08 OF THE LATEST EDITION OF THE STANDARD SPECIFICATIONS FOR ROAD & BRIDGE CONSTRUCTION.
2. THE PAVEMENT SURFACE TO BE REMOVED MAY BE EITHER HOT ASPHALT MIX OR P.C. CONCRETE. THE WORK SHALL BE PERFORMED ACCORDING TO ARTICLE 440.03 AND THE SPECIAL PROVISIONS FOR BUTT JOINTS.
3. THE SAW CUT JOINT SHALL BE PRIMED JUST PRIOR TO THE PLACING OF HOT ASPHALT MIX. THE WORK SHALL BE ACCORDING TO THE APPLICABLE PORTIONS OF ARTICLE 406.06.
4. COST OF SAW CUTS SHALL BE INCLUDED IN THE CONTRACT UNIT PRICE OF HOT ASPHALT MIX SURFACE REMOVAL - BUTT JOINT.

DETAIL OF RUMBLE STRIPS (LOCATION MODIFIED FROM IDOT STANDARD 642001)

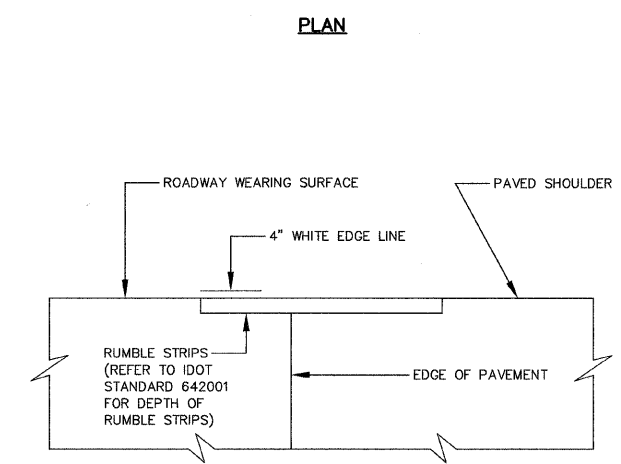
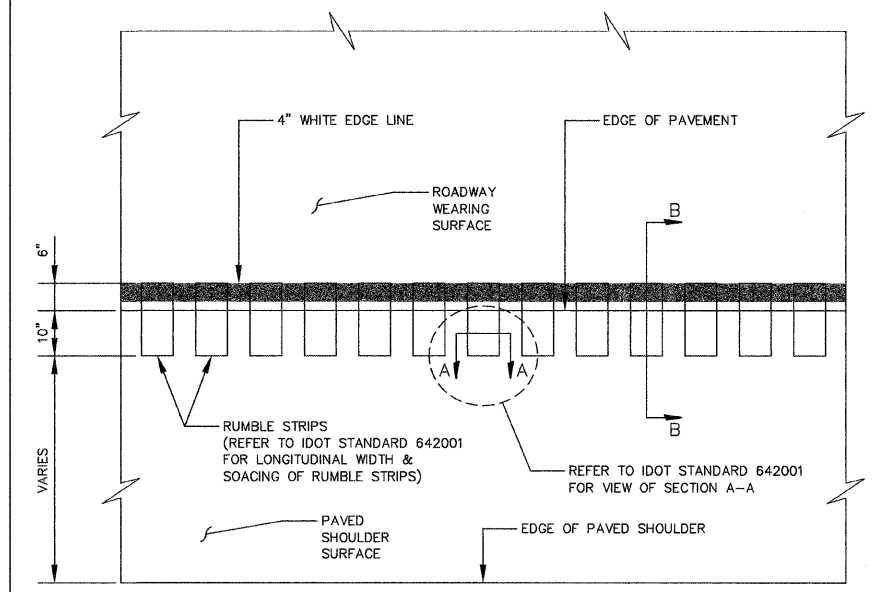

P:\040125\Roadway Plans\DWG\CDDVER, NOTES, SCHEDULES, TYPICALS, & DETAILS.dwg 10/11/2007 12:53:28 PM CDT

ENTRANCE, BUTT-JOINT, AND RUMBLE STRIP DETAILS

BLUFF ROAD (CTY. HWY. 6) BRIDGE REPLACEMENT OVER FOUNTAIN CREEK MONROE COUNTY, IL

REV.	DATE	DESCRIPTION

DRAWN BY: KBF/JWS	SHEET
DESIGNED BY: BJJ	31
CHECKED BY: SJK	OF 67 SHEETS
APPROVED BY: SJK	PROJECT DESCRIPTION
PROJECT NUMBER 116-040125	BLUFF RD. BRIDGE OVER FOUNTAIN CRK.
<input type="checkbox"/> ISSUED FOR REVIEW	<input type="checkbox"/> ISSUED FOR BIDDING
<input checked="" type="checkbox"/> ISSUED FOR CONSTR.	<input type="checkbox"/> RECORD DRAWING