

F.A.U. RTE.	SECTION	COUNTY	TOTAL SHEETS	SHEET NO.
8852	06-00056-01-WF	MADISON	81	51
STA.		TO STA.		
FED. ROAD DIST. NO.		ILLINOIS	FED. AID PROJECT	
SIGNING PLAN, SCHEDULE & DETAILS				
CONTRACT NO. 97324				

SIGN AND POST SCHEDULE

STATION	OFFSET	TYPE	DESCRIPTION	SIGN PANEL T1 72000100 (SQ FT)	SIGN PANEL T1 SPL 72000105 (SQ FT)	SIGN PANEL T2 SPL 72000205 (SQ FT)	SIGN PANEL T3 SPL 72000305 (SQ FT)	TUBULAR STEEL SIGN POST SUPPORT - BREAK AWAY				METAL AND WOOD POSTS			CONC FOUNDATION 73400100 (CU YD)			
								TUBULAR STEEL POST SIZE	STUB POST LENGTH (FOOT)	MAIN POST LENGTH		TUB STL SN SUPPORT BA 72700200 (POUND)	NO. OF POSTS	METAL POST TYPE A 72900100 (FOOT)		METAL POST TYPE B 72900200 (FOOT)	WOOD SIGN SUPPORT 73000100 (FOOT)	
										L1 (FOOT)	L2 (FOOT)							WEIGHT (POUND) PER FOOT
IL ROUTE 160 / BROADWAY																		
10+00	31' RT	W2-6	CIRCULAR INTERSECTION	6.3										1	17			
10+00	31' RT	W13-1 18"	ADVISORY SPEED (20 MPH)	2.3														
10+00	31' LT	DOT 12045	STATE ROUTE (IL 160)	5.0										1	14			
10+00	31' LT	M3-3	CARDINAL DIRECTION AUXILIARY (SOUTH)	2.0														
11+00	34.25' RT	ADGS-2	ADVANCED DEST. GUIDE				46.8	TS4 x 3 x 1/4	2.5	12	12	10.51	305		1.4			
11+94	CL	R4-7	KEEP RIGHT	5.0										1	14			
12+18	54.5' LT	R1-2 30"	YIELD	3.9										1	14			
12+18	54.5' LT	R5-1 30"	DO NOT ENTER	6.3														
12+30	29' RT	W3-2-30	YIELD AHEAD	6.3										1	15			
12+30	24' LT	R5-1 30"	DO NOT ENTER	6.3										1	14			
12+74	24' RT	W11A-2	PEDESTRIAN TRAFFIC	6.3										1	15			
12+85	28' LT	W11A-2	PEDESTRIAN TRAFFIC	6.3										1	15			
13+04	35' RT	R1-2 30"	YIELD	3.9										1	14			
13+04	35' RT	R5-1 30"	DO NOT ENTER	6.3														
13+08	2.3' LT	DGS-3	DESTINATION GUIDE			14.0		TS3 x 2 x 1/4	2.25	10		7.11	103		0.7			
13+40	122' LT	R2-1	SPEED LIMIT (30 MPH)	5.0										1	14			
13+65	24' RT	R6-1R	ONE WAY	3.0										1	12			
14+28	21' LT	R6-1R	ONE WAY	3.0										1	12			
14+83	2.5' RT	DGS-4	DESTINATION GUIDE		6.0									1	13			
14+87	34.5' LT	R1-2 30"	YIELD	3.9										1	14			
14+87	34.5' LT	R5-1 30"	DO NOT ENTER	6.3														
15+07	35' RT	W11A-2	PEDESTRIAN TRAFFIC	6.3										1	15			
15+17	24' LT	W11A-2	PEDESTRIAN TRAFFIC	6.3										1	15			
15+25	1' RT	R4-7	KEEP RIGHT	5.0										1	15			
15+96	24' LT	W3-2-30	YIELD AHEAD	6.3										1	15			
17+30	22' LT	W2-6	CIRCULAR INTERSECTION	6.3										1	17			
17+30	22' LT	W13-1	ADVISORY SPEED (20 MPH)	2.3														
TOTALS (POPLAR AND BROADWAY)				401	12	28	89						751	60	63	626	177	4.2

- NOTES:
1. UNLESS OTHERWISE NOTED, ALL SIGNS SHALL BE CONVENTIONAL SIGNS AS SPECIFIED IN THE LATEST ADDITION OF THE MANUAL ON UNIFORM TRAFFIC CONTROL DEVICES.
 2. ALL SIGNS SHALL BE INSTALLED PER IDOT STANDARD 720006. STATIONS AND OFFSETS STATED HERE ARE APPROXIMATE. THE ENGINEER SHALL ADJUST THE SIGNS TO COMPLY WITH THE STANDARD AND TO MATCH FIELD CONDITIONS.
 3. ALL PEDESTRIAN TRAFFIC SIGNS SHALL BE FLORESCENT YELLOW-GREEN AND CONTAIN CROSS WALK LINES.
 4. SIGN AREAS CALCULATED ACCORDING TO ARTICLE 720.03 OF THE STANDARDS SPECIFICATION.

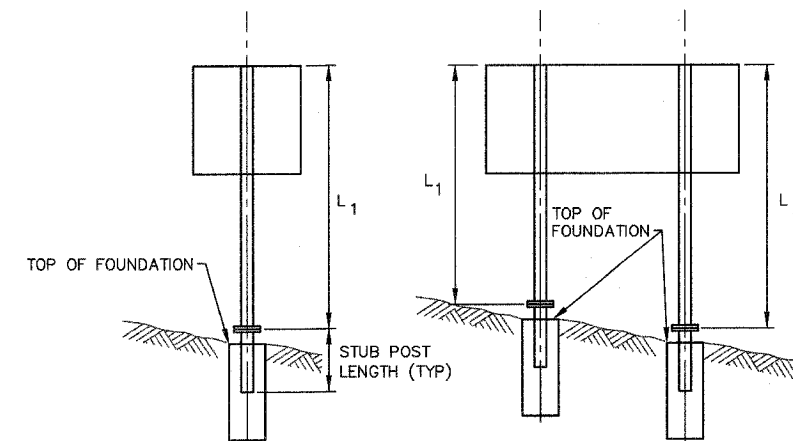

PROPOSED TUBULAR STEEL SIGN SUPPORT DETAIL
NOT TO SCALE