

STATE OF ILLINOIS  
DEPARTMENT OF TRANSPORTATION

ROUTE	SECTION	COUNTY	TOTAL SHEETS	SHEET NO.
F.A.I. 24	*	MASSAC	99	99

FED. ROAD DIST. NO. 7 ILLINOIS

\*(64-3B) I-6  
CONTRACT NO. 98990

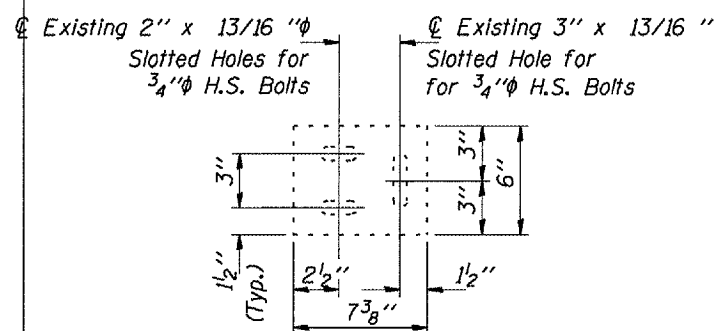

**EXISTING PLATE "C"**  
FOR INFORMATION ONLY

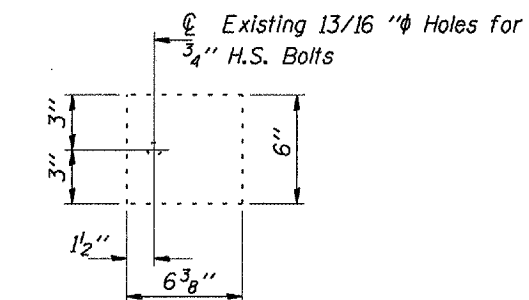

**EXISTING PLATE "D"**  
FOR INFORMATION ONLY

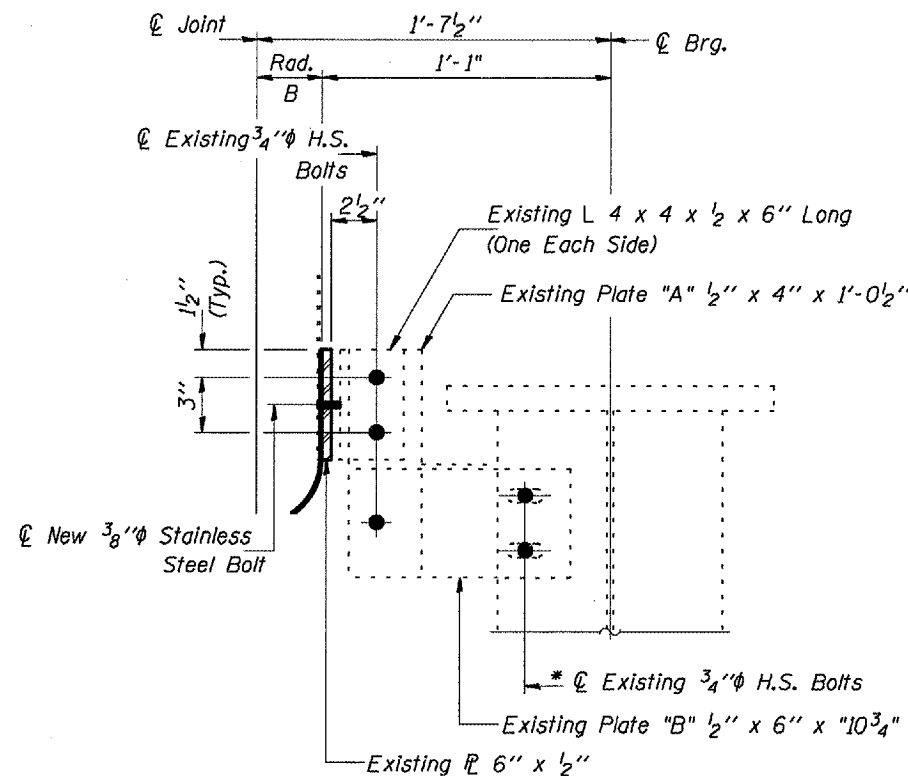

**TYPE 2 CONNECTION**  
**LOCATION D**

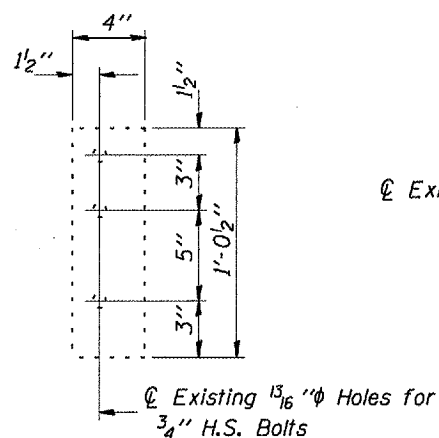

**EXISTING PLATE "A"**  
FOR INFORMATION ONLY

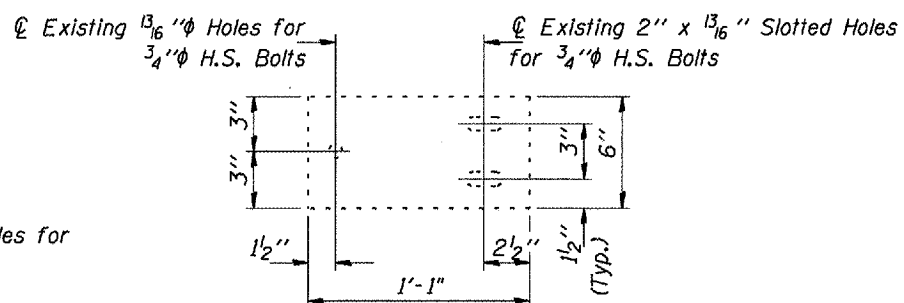

**EXISTING PLATE "B"**  
FOR INFORMATION ONLY

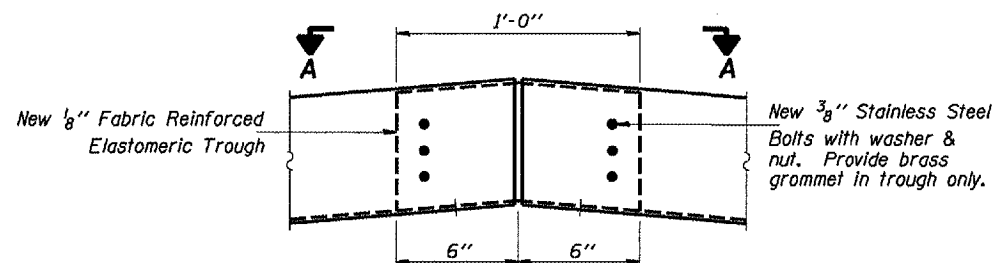

**TROUGH SPLICE DETAIL**



**VIEW A-A**

**TROUGH DETAILS**  
**F.A.I. 24 OVER OHIO RIVER**  
**MASSAC COUNTY**  
**S.N. 064-0035**