

ELEVATION
TYPICAL INTERIOR UNIT
 Even number of panels/interior unit required.

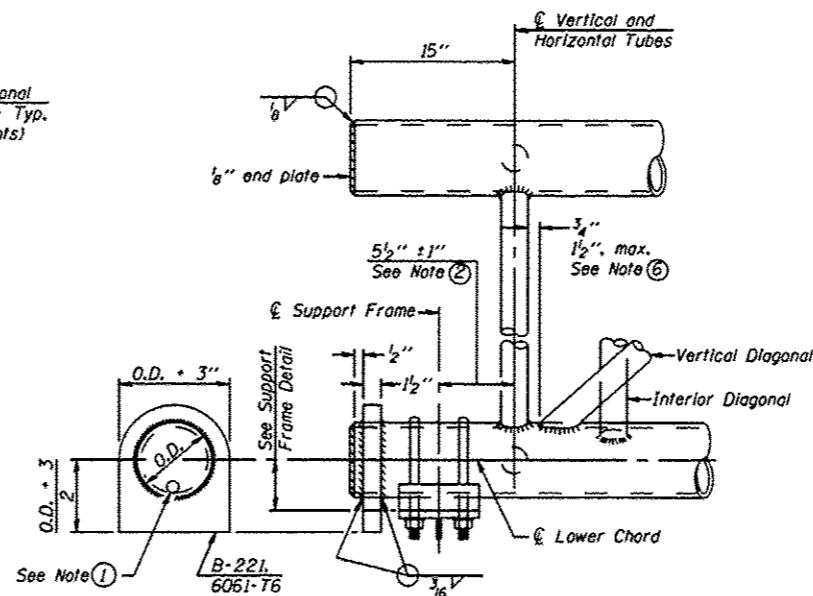

SUPPORT END DETAIL FOR EXTERIOR UNIT

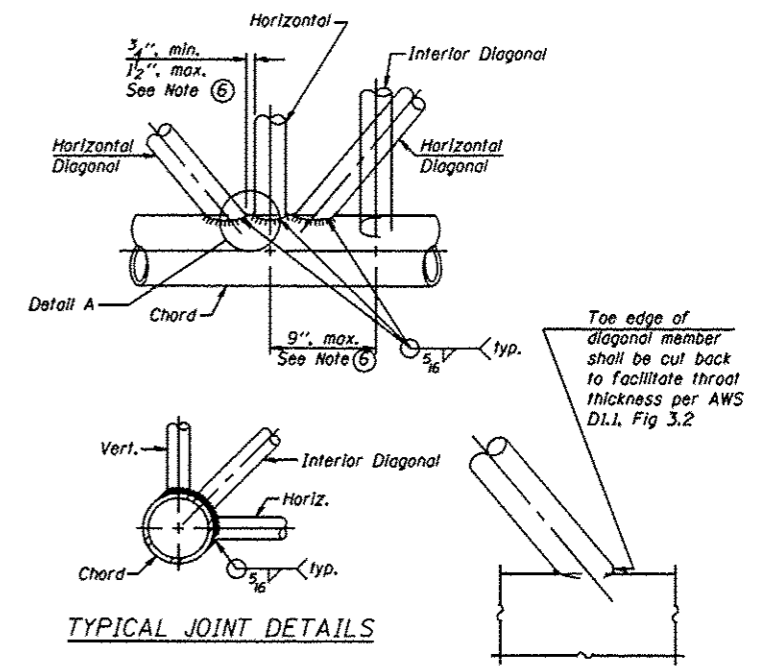

TYPICAL JOINT DETAILS

DETAIL A

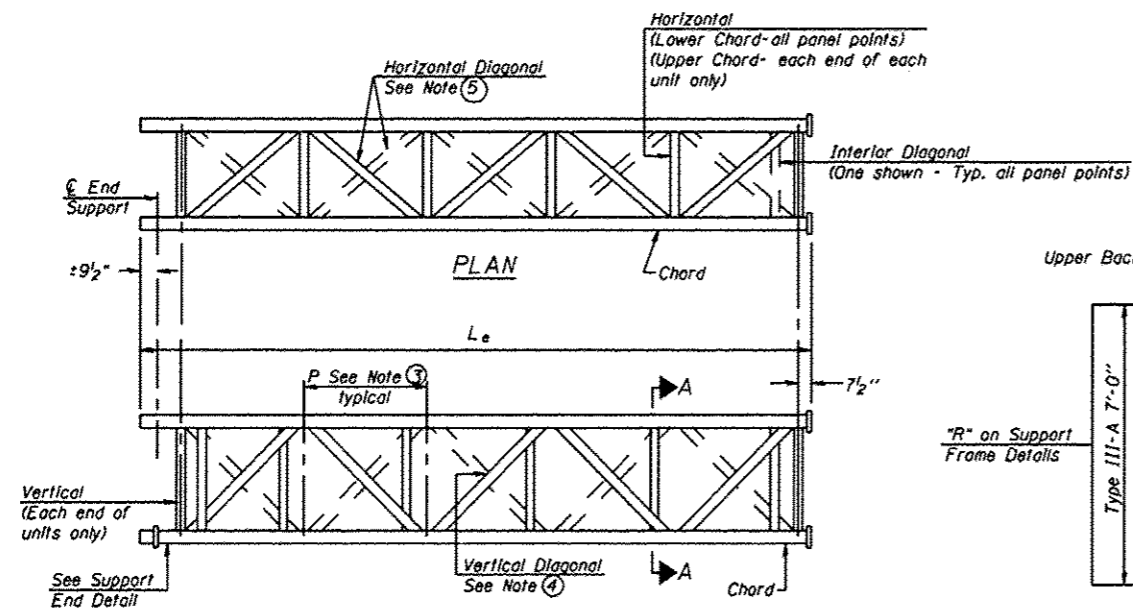

ELEVATION
TYPICAL EXTERIOR UNIT
 Even or odd number of panels/exterior units allowed.

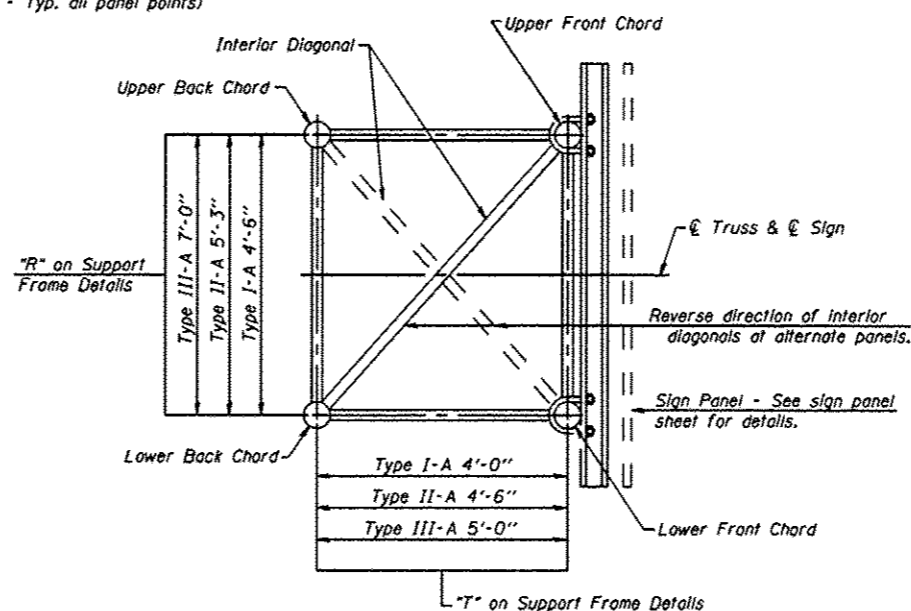

SECTION A-A

- ① Contractor may alternatively use standard aluminum drive-fit cap to close end. 1/2" Ø drain hole in end plate/drive-fit cap. (Typ. at ends of all chords)
- ② 5 1/2" end dimension may vary by +/- 1" to provide uniform panel spacing (P).
- ③ Panel spacing (P) shall be uniform for entire truss and between 4'-0" and 5'-0" for Type I-A or 4'-0" and 5'-6" for Types II-A and III-A.
- ④ Vertical Diagonals in front and back face shall alternate.
- ⑤ Hidden lines show wind bracing alternates direction between planes of top and bottom chords.
- ⑥ All diagonals shall be detailed for minimum offset from the panel point based on the following: Offset shall be such as to provide a 3/4" minimum to 1 1/2" maximum clearance between any diagonal and any horizontal or vertical member, and to provide clearance for U-bolt connections of signs or walkway brackets.

OS-A-2

1-20-11

FILE NAME * #FILE#	USER NAME * #USER#	DESIGNED -	REVISED -
		DRAWN -	REVISED -
		CHECKED -	REVISED -
		DATE -	REVISED -

STATE OF ILLINOIS
 DEPARTMENT OF TRANSPORTATION

OVERHEAD SIGN STRUCTURES - ALUMINUM TRUSS
 DETAILS FOR TRUSS TYPES I-A, II-A AND III-A

F.A. RTE.	SECTION	COUNTY	TOTAL SHEETS	SHEET NO.
XAB	D:6_DVQSIUSIBBERL12:23	VARIOUS	32	11
				CONTRACT NO. 46226
ILLINOIS FED. AID PROJECT				

SCALE: _____ SHEET NO. ____ OF ____ SHEETS STA. _____ TO STA. _____