

**COMBINATION CONCRETE CURB AND GUTTER  
REMOVAL AND REPLACEMENT DETAIL**

**NOTES:**

1. THE PROPOSED IMPROVEMENT SHALL BE PCC SIDEWALK 5" WITH SUBBASE GRANULAR MATERIAL TYPE B 4", OR TOPSOIL 6" AND SEEDING.
2. CURB AND GUTTER REPLACEMENT SHALL MATCH THE SHAPE OF THE EXISTING CURB AND GUTTER UNLESS OTHERWISE SPECIFIED BY THE ENGINEER.
3. THE HMA SURFACE SHALL BE PAVED 1/4" HIGHER THAN THE EDGE OF THE PROPOSED GUTTER.
4. THE EXISTING PAVEMENT SHALL BE SAW CUT TO THE FULL DEPTH OF THE PAVEMENT 2' FROM THE EDGE OF EXISTING CURB AND GUTTER TO BE REMOVED AND REPLACED. THE REMOVAL OF THE EXISTING PAVEMENT AND THE FULL DEPTH SAW CUT SHALL BE INCLUDED IN THE CONTRACT UNIT COST FOR COMBINATION CURB AND GUTTER REMOVAL (SPECIAL).
5. THE THICKNESS OF THE SUBBASE GRANULAR MATERIAL, TYPE B SHALL BE INCREASED IF DIRECTED BY THE ENGINEER. REMOVAL AND REPLACEMENT IN EXCESS OF THE SPECIFIED 4" WILL BE PAID FOR IN ACCORDANCE WITH ARTICLE 109.04 OF THE STANDARD SPECIFICATIONS.
6. LONGITUDINAL BARS, IF ENCOUNTERED IN THE EXISTING CURB AND GUTTER, ARE NOT TO BE REPLACED. CUTTING AND REMOVING LONGITUDINAL BARS SHALL BE INCLUDED IN THE CONTRACT UNIT COST FOR COMBINATION CURB AND GUTTER REMOVAL (SPECIAL).
7. THE REMOVAL OF THE EXISTING COMBINATION CONCRETE CURB AND GUTTER SHALL BE INCLUDED IN THE CONTRACT UNIT COST FOR COMBINATION CURB AND GUTTER REMOVAL (SPECIAL).
8. THE REMOVAL AND REPLACEMENT OF THE EXISTING CURB AND GUTTER AND EXISTING PAVEMENT SHALL BE DONE IN ACCORDANCE WITH THE APPLICABLE PORTIONS OF SECTION 311, 406, 440, AND 606 OF THE STANDARD SPECIFICATIONS.
9. THE LOCATIONS OF REMOVAL AND REPLACEMENT OF EXISTING CURB AND GUTTER SHALL BE SHOWN ON THE PLANS OR AS DIRECTED BY THE ENGINEER.
10. THIS WORK WILL BE INCLUDED IN THE CONTRACT UNIT PRICE FOR COMBINATION CURB AND GUTTER REMOVAL (SPECIAL).

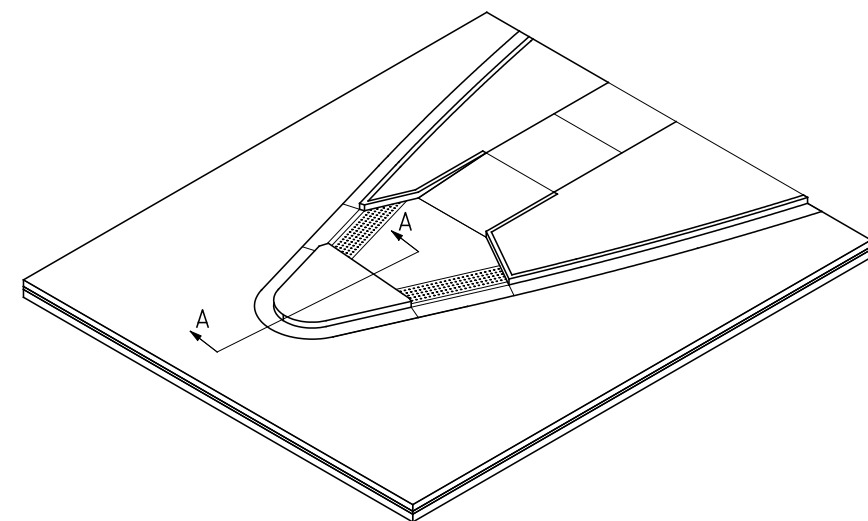

**TYPICAL MEDIAN NOSE DETAIL  
ISOMETRIC VIEW  
NOT TO SCALE**

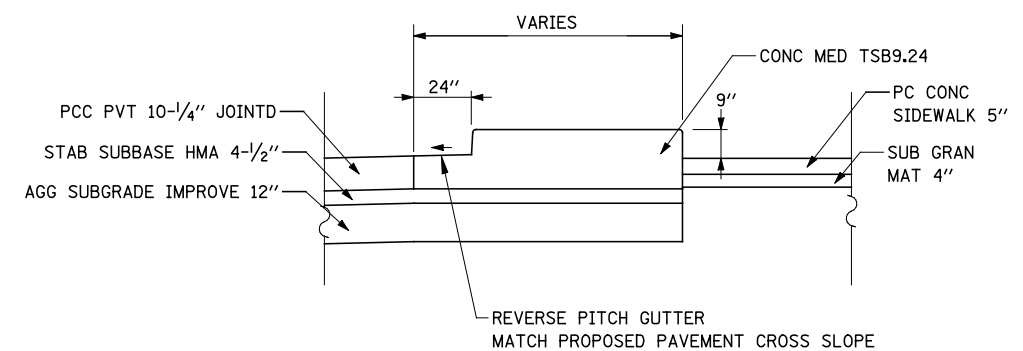

**SECTION A-A  
NOT TO SCALE**

|             |                      |                        |           |
|-------------|----------------------|------------------------|-----------|
| FILE NAME = | USER NAME = #USER#   | DESIGNED <i>PJO</i>    | REVISED - |
| #FILEL#     |                      | DRAWN <i>KES</i>       | REVISED - |
|             | PLOT SCALE = #SCALE# | CHECKED <i>JCM</i>     | REVISED - |
|             | PLOT DATE = #DATE#   | DATE <i>10/15/2012</i> | REVISED - |

**STATE OF ILLINOIS  
DEPARTMENT OF TRANSPORTATION**

**ROADWAY DETAILS**

SCALE: SHEET NO. 1 OF 1 SHEETS STA. TO STA.

|                           |                   |        |                    |           |
|---------------------------|-------------------|--------|--------------------|-----------|
| F.A.P. RTE.               | SECTION           | COUNTY | TOTAL SHEETS       | SHEET NO. |
| 338                       | (112 & 113) WRS-5 | DUPAGE | 963                | 287       |
| <b>DT-04</b>              |                   |        | CONTRACT NO. 60I31 |           |
| ILLINOIS FED. AID PROJECT |                   |        |                    |           |