

DETAIL - "D"

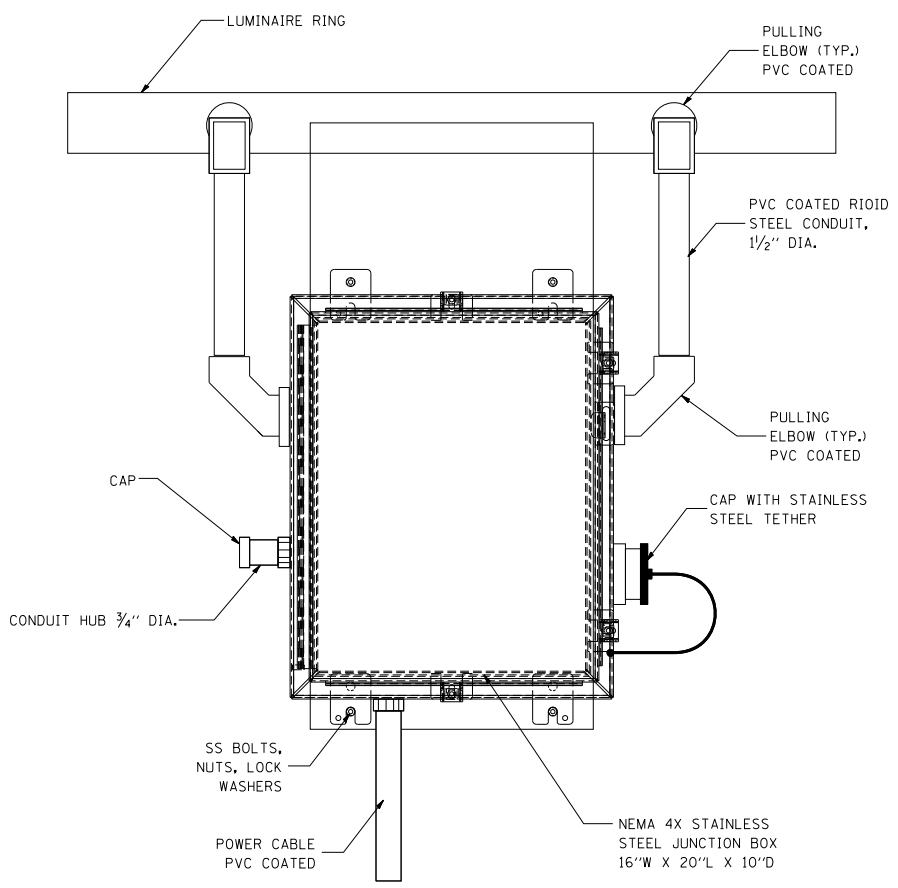

FRONT VIEW
N.T.S.

LUMINAIRE RING TERMINAL BOX

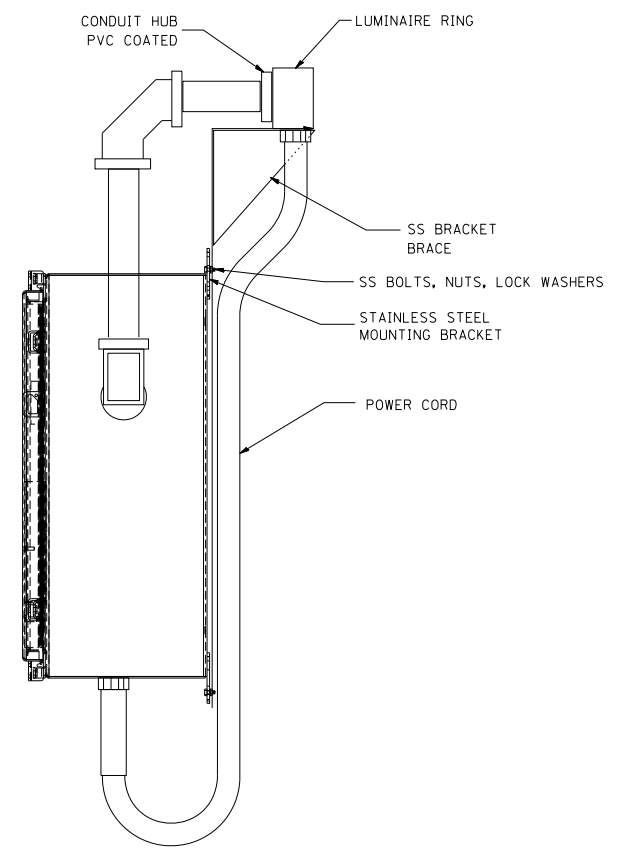

SIDE VIEW
N.T.S.

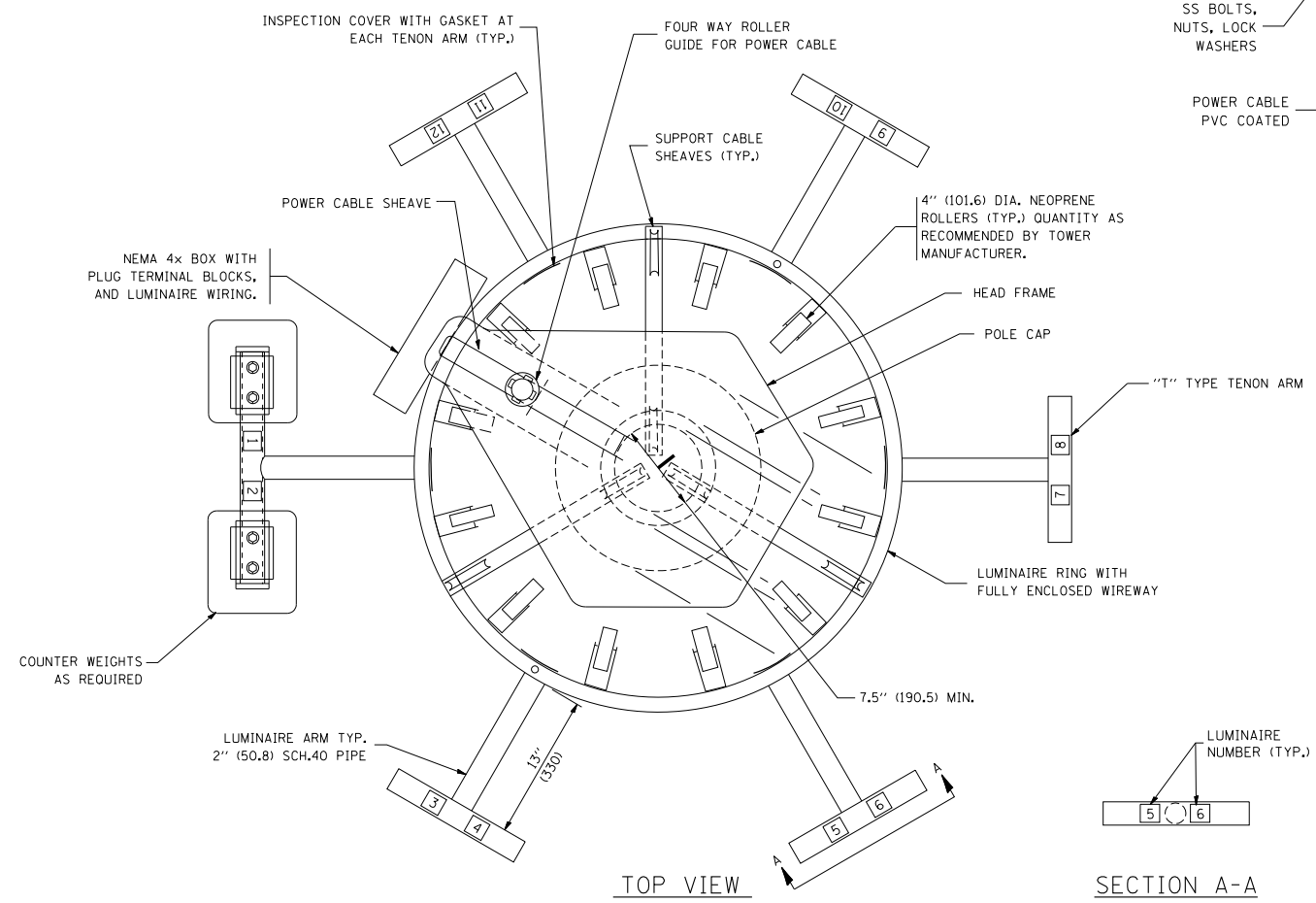

TOP VIEW

SECTION A-A

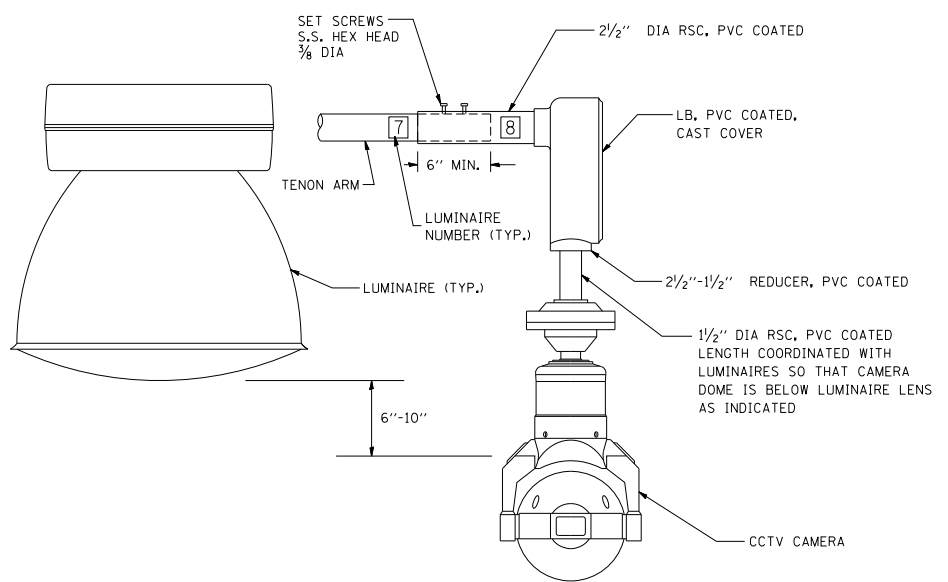

CCTV CAMERA MOUNTING DETAIL

NOTES:

- LUMINAIRE WIRES SHALL EXTEND 24 INCHES (609 mm) LONGER THAN THEIR RESPECTIVE TENON ARM AND SHALL BE TRAINED BACK INTO THE ARM WHICH SHALL THEN BE CLOSED WITH A CAP AS SPECIFIED ALL WIRES SHALL BE CAPPED WITH HEAT SHRINK INSULATING BOOTS, CRIMP CAPS ARE UNACCEPTABLE. ALL RING WIRES SHALL BE TAGGED WITH WIRE MARKERS AT BOTH ENDS THE TENON ARMS SHALL ALSO BE TAGGED CORRESPONDING TO THE WIRING CONTAINED WITHIN.
- SPLICING WILL NOT BE ALLOWED WITHIN THE LUMINAIRE RING.
- ALL TOWER SHAFT HARDWARE, SUCH AS GROUND LUGS, JUNCTION BOXES, HARDWARE FOR THE HANDHOLE DOOR, INCLUDING THE HANDLE/LATCH MECHANISM, HINGE AND DOOR STOP, SHALL BE STAINLESS STEEL. ALL CONDUIT AND CONDUIT FITTINGS SHALL BE PVC COATED GALVANIZED STEEL.
- ALL MULTI-CONDUCTOR CABLES SHALL BE FITTED WITH A HEAT-SHRINK MULTI-LEG BOOT. THE BOOT SHALL MEET MILITARY SPECIFICATION MIL-I-81765/1.

FILE NAME = W:\diststd\22x34\be500.dgn	USER NAME = leuss	DESIGNED - DRAWN -	REVISED - R. TOMSONS 08-04-03 REVISED - R. TOMSONS 05-11-09
	PLOT SCALE = 50.0000' / IN.	CHECKED -	REVISED - R. TOMSONS 09-02-10
	PLOT DATE = 11/22/2010	DATE -	REVISED -

STATE OF ILLINOIS
DEPARTMENT OF TRANSPORTATION

HIGH MAST LIGHT TOWER
90 FT TO 110 FT (27 m TO 34 m)

SCALE: NONE	SHEET NO. 2 OF 3 SHEETS	STA.	TO STA.
-------------	-------------------------	------	---------

F.A. RTE.	SECTION	COUNTY	TOTAL SHEETS	SHEET NO.
338	(112 & 113)WRS-5	DUPAGE	963	713
BE-500		CONTRACT NO.60I31		
FED. ROAD DIST. NO. 1 ILLINOIS FED. AID PROJECT				