

PLAN

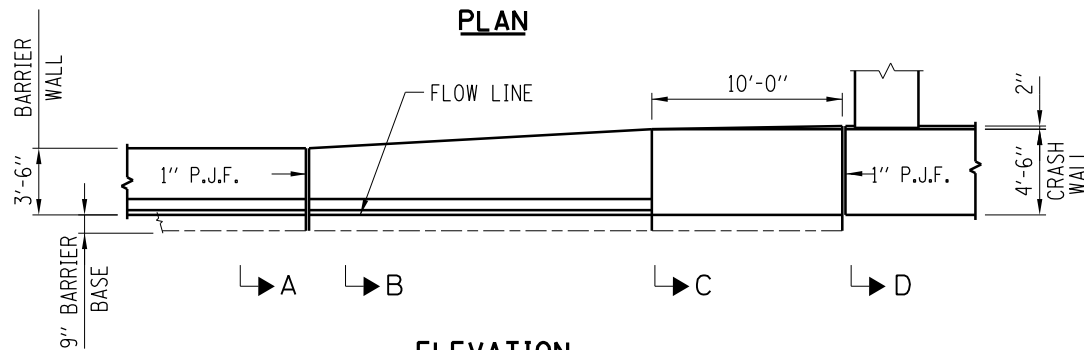

ELEVATION

**CONCRETE MEDIAN BARRIER TRANSITION, TYPE V-F
AT BRIDGE PIERS**

NOTES:

1. 1" DEEP CONTRACTION JOINTS SHALL BE CONSTRUCTED IN THE CONCRETE BARRIER WALL AND IN THE CONCRETE BARRIER BASE. CONTRACTION JOINTS SHALL ALSO BE CONSTRUCTED AT BOTH SIDES OF ALL DRAINAGE STRUCTURES. MAXIMUM JOINT SPACING SHALL BE 30'
2. THE FORMING OF CONTRACTION JOINTS SHALL BE DONE WITH AN APPROVED FINISHING TOOL AT THE DISCRETION OF THE ENGINEER SUBJECT TO THE SATISFACTORY CONTROL OF CRACKING. THE SAWING OF CONTRACTION JOINTS IN THE BARRIER WALL SHALL NOT BE PERMITTED.
3. TAPER LENGTH REQUIRED FOR THE WIDTH TRANSITION WILL BE 18'-0" MINIMUM.
4. TOP SHOULDER EDGE OF GUTTER SLAB SHALL MATCH THE TOP OF SHOULDER ELEVATION.
5. GUTTER PROFILE IN THE VICINITY OF SAG VERTICAL CURVES, ALONG FLAT GRADES AND AT THE MEETING OF PROPOSED AND EXISTING GUTTER, SHALL BE CAREFULLY CONTROLLED AND FIELD ADJUSTED IF NECESSARY TO ENSURE POSITIVE DRAINAGE AND AVOID PONDING.

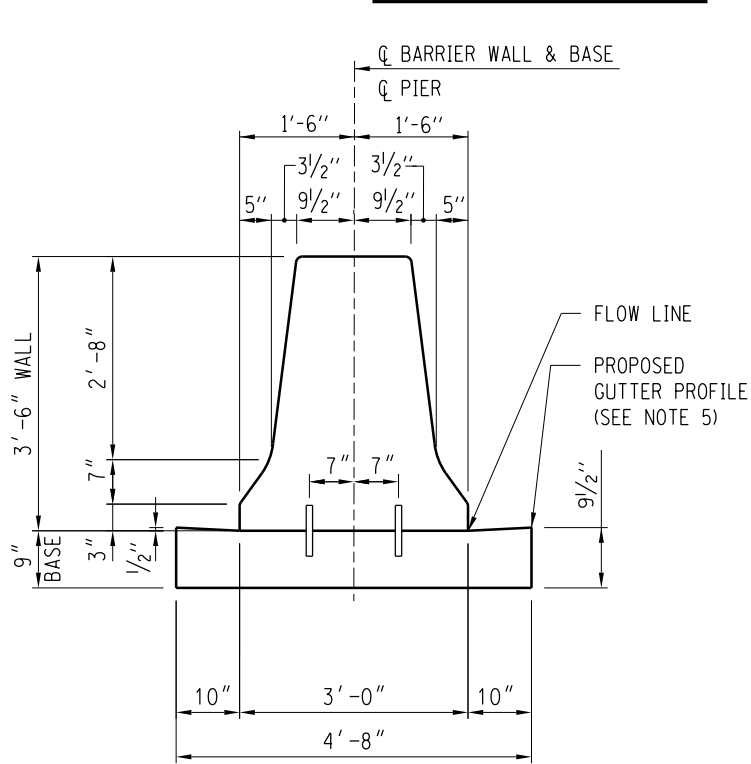

SECTION A-A

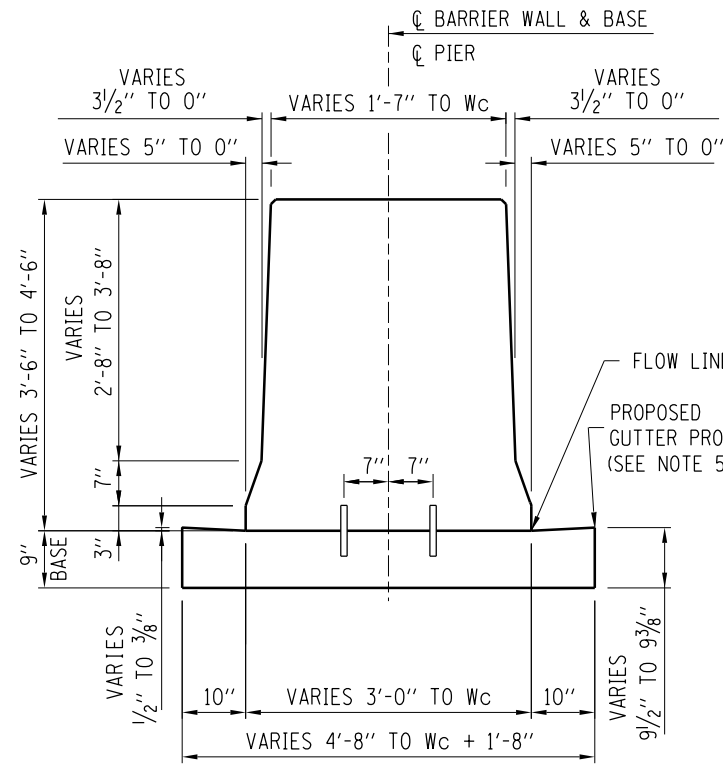

SECTION B-B

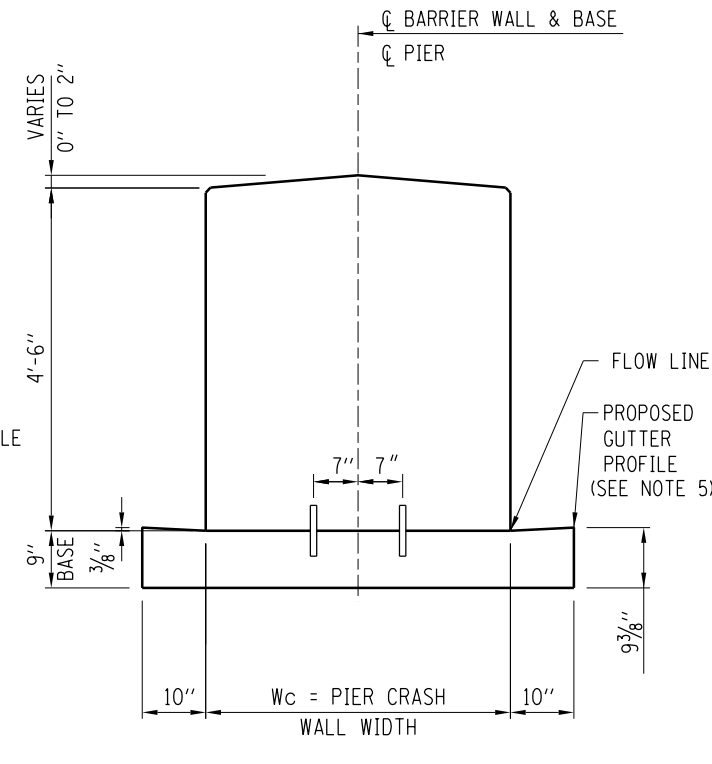

SECTION C-C

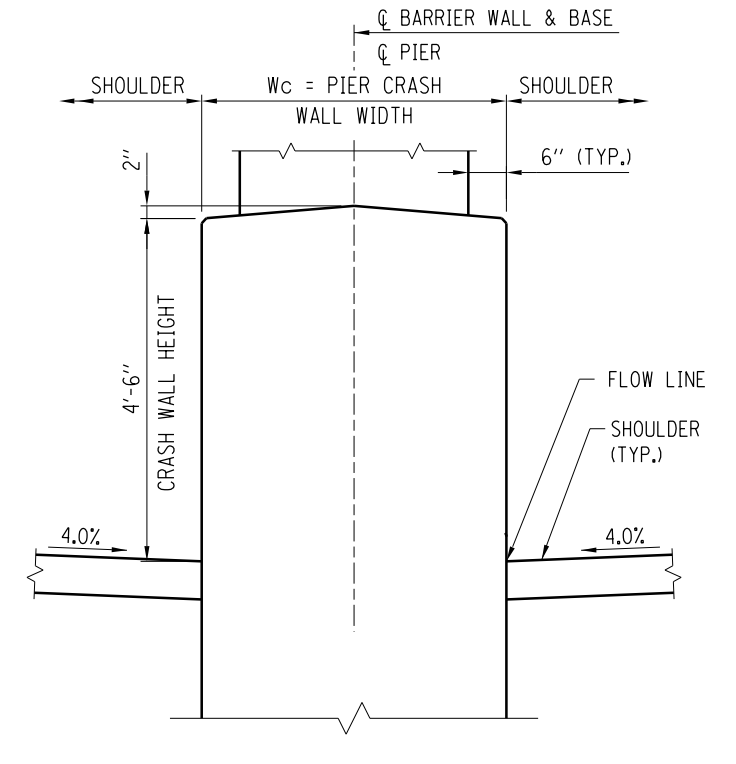

SECTION D-D

CONTRACT 60I31 SHEET 922 OF 963



APPROVED *Paul Kovacs* CHIEF ENGINEER DATE 2-7-2012

DATE	REVISIONS

CONCRETE MEDIAN BARRIER TRANSITION, TYPE V-F AT BRIDGE PIERS

STANDARD C13-00