

SIGN TS-1 (O)

COLOR: BACKGROUND - FLUORESCENT ORANGE (O)
BORDER AND SYMBOL - BLACK

SIZE: 48"x48"

MOUNTING HOLES: 1/16" DIA., 4 HOLES SPACED AS SHOWN

NOTE: SIGN TS-1L IS SHOWN; REVERSE SYMBOL FOR SIGN TS-1R

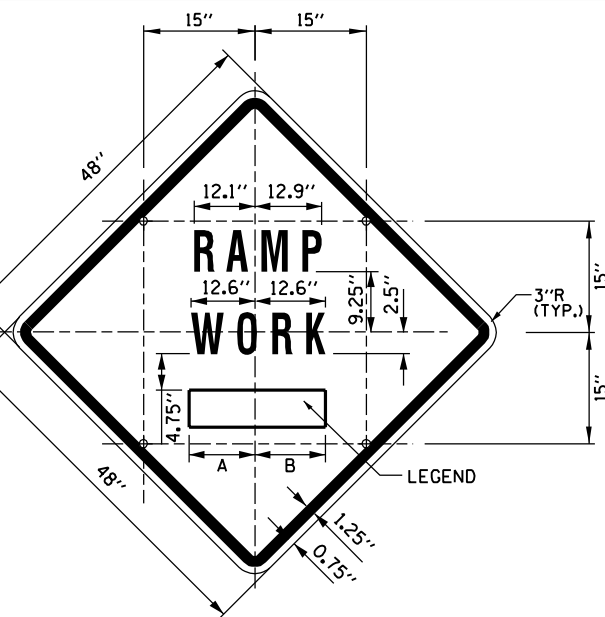

SIGN TS-2 (O)

COLOR: BACKGROUND - FLUORESCENT ORANGE (O)
BORDER AND SYMBOL - BLACK

SIZE: 48"x48"

LETTERING: 7" FEDERAL SERIES D
MOUNTING HOLES: 1/16" DIA., 4 HOLES SPACED AS SHOWN

SIGN NO.	LEGEND	A	B
TS-2A	AHEAD	15.50"	15.50"
TS-2B	500 FT	14.25"	15.13"
TS-2C	1000 FT	14.88" L2	15.75" L2
TS-2D	1500 FT	14.88" L2	15.75" L2
TS-2E	1/2 MILE	15.75" L3	15.75" L3
TS-2F	1 MILE	13.06"	13.06"

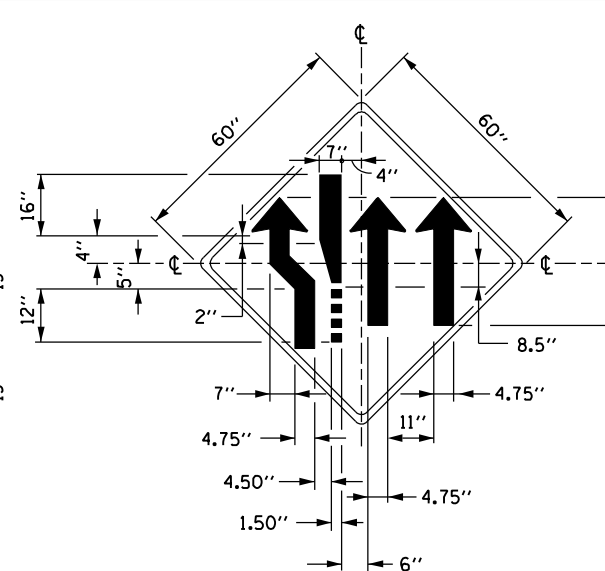

SIGN TS-1CL (O)

COLOR: BACKGROUND - FLUORESCENT ORANGE (O)
BORDER AND SYMBOL-BLACK
(NON-REFLECTORIZED)

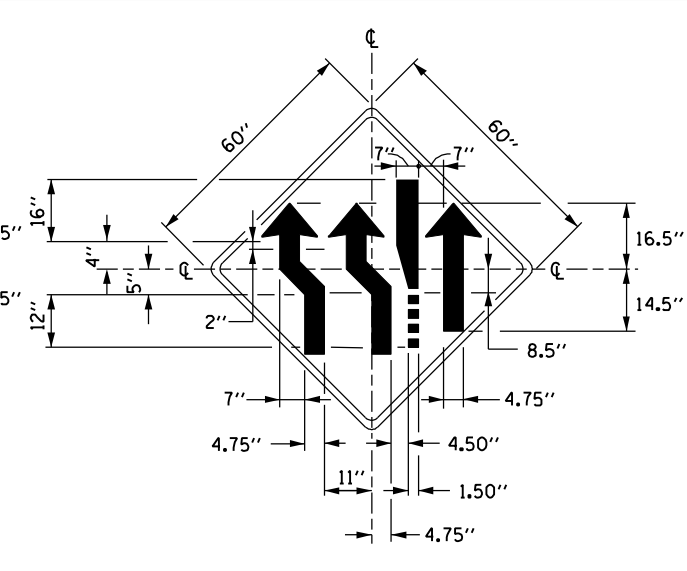

SIGN TS-1CR (O)

COLOR: BACKGROUND - FLUORESCENT ORANGE (O)
BORDER AND SYMBOL-BLACK
(NON-REFLECTORIZED)

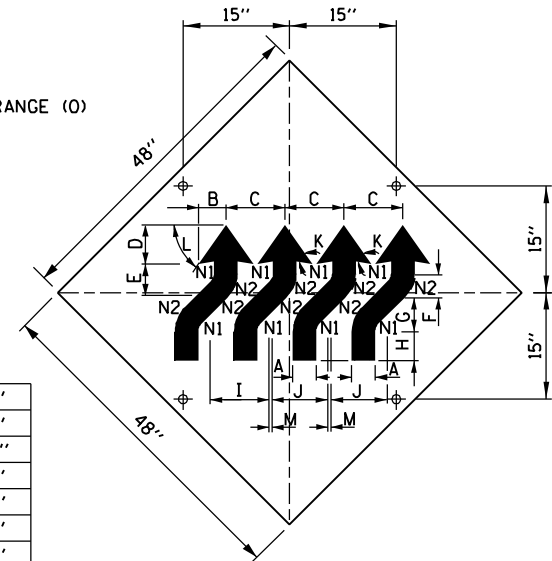

SIGN WI-4dR (O)

COLOR: BACKGROUND, FLUORESCENT ORANGE (O)
TYPE A REFLECTIVE SHEETING PER STANDARD SPECIFICATIONS (*A)
BORDER AND LETTERS-BLACK

SIZE: 48"x48"

MOUNTING HOLES: 1/16" DIA., 4 HOLES SPACED AS SHOWN.

A	4 1/2"
B	5 3/4"
C	12 1/2"
D	7 3/4"
E	6 1/2"
F	4 1/2"
G	6 1/2"
H	6"
I	12 3/4"
J	12"
K	45°
L	55°
M	0 3/4"
N1	2"
N2	6 1/2"

NOTES:

- ALL LETTERING IS DESIGNATED BY SIZE AND SERIES IN ACCORDANCE WITH THE LATEST EDITION OF "STANDARD ALPHABETS FOR HIGHWAY SIGNS AND PAVEMENT MARKINGS" AS PUBLISHED BY THE U.S. DEPARTMENT OF TRANSPORTATION. LETTERING SPACING SHALL BE IN ACCORDANCE WITH THIS GUIDE EXCEPT WHERE NOTED.
- SYMBOLS AND ARROWS SHALL CONFORM TO THE DETAILS SHOWN IN THE LATEST EDITION OF "STANDARD HIGHWAY SIGNS" AS PUBLISHED BY THE U.S. DEPARTMENT OF TRANSPORTATION.
- SEE THE CONTRACT REQUIREMENTS FOR ADDITIONAL NOTES AND SPECIFICATIONS.
(O) FLUORESCENT ORANGE REFLECTIVE SHEETING PER THE STANDARD SPECIFICATIONS.
(*A) - REFLECTIVE SHEETING PER THE STANDARD SPECIFICATIONS.
- DIMENSIONS INDICATED THUS L ARE BASED ON A REDUCTION IN STANDARD LETTERING SPACING AS SHOWN BELOW:
L1 SPACING REDUCED BY 25%
L2 SPACING REDUCED BY 40%
L3 SPACING REDUCED BY 50%

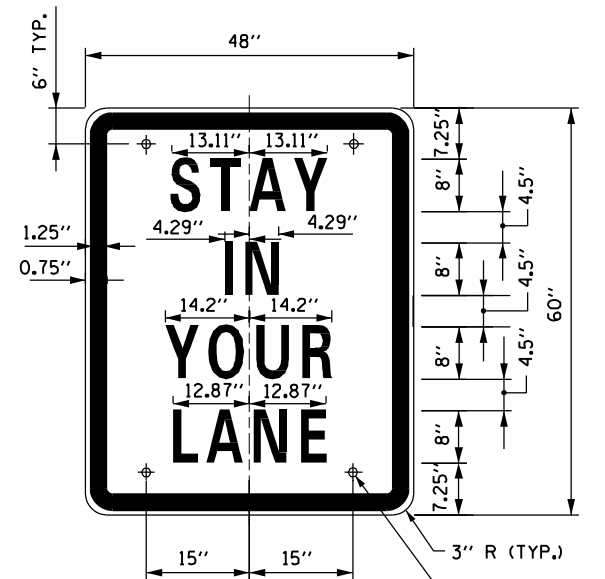

SIGN TS-3

COLOR: BACKGROUND - WHITE (REFLECTORIZED)(*A)
BORDER AND LETTERS - BLACK

SIZE: 48"x60"

LETTERING: LEGEND - 8" FEDERAL SERIES D

MOUNTING HOLES: 1/16" DIA., 4 HOLES, SPACED AS SHOWN

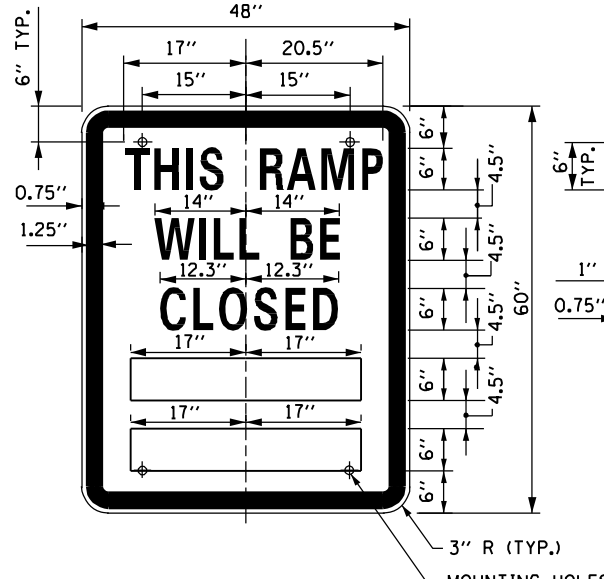

SIGN TS-4

COLOR: BACKGROUND - WHITE (REFLECTORIZED)(*A)
BORDER AND LETTERS - BLACK

SIZE: 48"x60"

LETTERING: LEGEND - 6" FEDERAL SERIES C

MOUNTING HOLES: 1/16" DIA., 4 HOLES, SPACED AS SHOWN

RAMP CLOSURE ADVANCE INFORMATION SIGN

THE VARIABLE MESSAGE WITH DATES FOR THE BOTTOM TWO LINES SHALL BE DETERMINED BY THE ENGINEER AND GIVEN TO THE CONTRACTOR BEFORE THE REQUIRED FIELD ERECTION DATE.

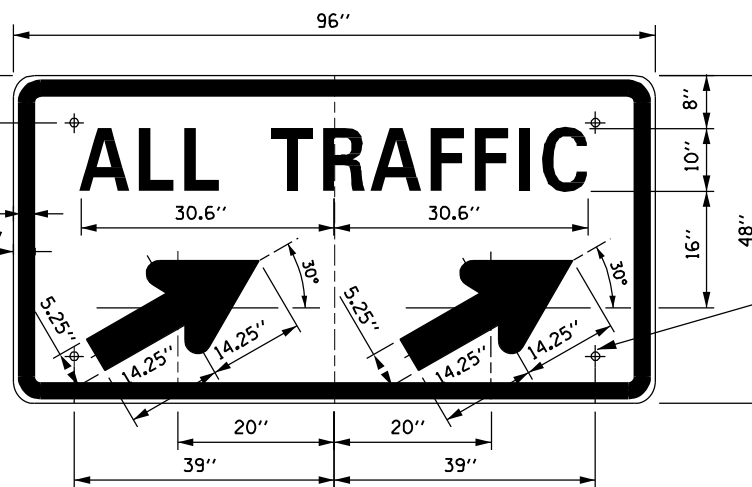

SIGN TS-5a & TS-5b

COLOR: BACKGROUND - WHITE (REFLECTORIZED)(*A)
BORDER AND LETTERS - BLACK
ARROW - BLACK

SIZE: 96"x48"

LETTERING: 10" FEDERAL SERIES D

MOUNTING HOLES: 1/16" DIA., 4 HOLES, SPACED AS SHOWN

NOTE: SIGN TS-5a IS SHOWN, SUBSTITUTE LEGEND " " FOR " " FOR SIGN TS-5b

MOUNTING HOLES TYP. (4 REQ'D)

DATE	REVISIONS
5-1-2009	DELETED FLASHING ARROW BOARDS
1-1-2011	ADDED SIGN COLOR DESIGNATION

