

I-190
 PROPOSED TYPICAL CROSS SECTION
 E.B. STA. 51+07 TO STA. 70+68
 W.B. STA. 75+24 TO STA. 142+56
 E.B. STA. 91+81 TO STA. 143+48

LEGEND

- ① EXISTING HOT-MIX ASPHALT SURF. CSE., ± 5"
- ② EXISTING C.R.C. PAVEMENT, 11"
- ③ EXISTING SUB-BASE GRAN. MATL., 6"
- ④ EXISTING HOT-MIX ASPHALT SHOULDER
- ⑤ EXISTING PIPE UNDERDRAIN
- ⑥ EXISTING AGGREGATE SHOULDER TYPE "B"
- ⑦ EXISTING CONC BARRIER WALL SINGLE FACE
- ⑧ PROPOSED HOT-MIX ASPHALT SURFACE REMOVAL, 2 1/4" (RAMPS)
- ⑨ PROPOSED HOT-MIX ASPHALT SURFACE REMOVAL, 2" (MAINLINE) **
- ⑩ PROPOSED HOT-MIX ASPHALT SURFACE REMOVAL, 4" (MAINLINE) **
- ⑪ PROPOSED HOT-MIX ASPHALT SURFACE REMOVAL, 3 3/4" (OUTSIDE & INSIDE MAINLINE SHOULDERS)
- ⑫ PROPOSED POLYMERIZED HOT-MIX ASPHALT BINDER COURSE, STONE MATRIX ASPHALT, N80, 2"
- ⑬ PROPOSED POLYMERIZED HOT-MIX ASPHALT SURFACE COURSE, STONE MATRIX ASPHALT, N80, 2"
- ⑭ PROPOSED HOT-MIX ASPHALT BINDER COURSE, IL-19, N70, 2 1/4"
- ⑮ PROPOSED HOT-MIX ASPHALT SURFACE COURSE, MIX. "D", N70, 1 1/2"
- ⑯ PROPOSED SHOULDER RUMBLE STRIP, 16"
- ⑰ PROPOSED AGGREGATE WEDGE SHOULDER, TYPE "B"
- ⑱ PROPOSED GRADING AND SHAPING SHOULDER
- ⑲ PROPOSED POLYMERIZED LEVELING BINDER, IL-4.75, N50, 3/4"

* CONTRACTOR SHALL PATCH BEFORE MILLING
 ** SEE SUGGESTED SEQUENCE OF STAGING FOR PROPOSED MILLING THICKNESS.

PROPOSED TYPICAL CROSS SECTION

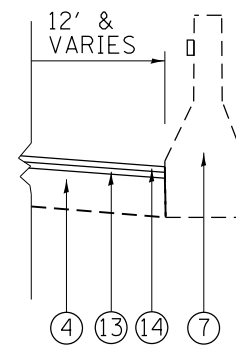

PROPOSED TYPICAL CROSS SECTION

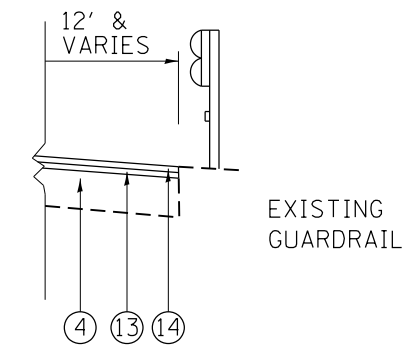

FILE NAME = c:\pwork\pwork\dot\rodriquezma\d0299718\0132812-sht-typical.dgn	USER NAME = rodriquezma	DESIGNED -	REVISED -	STATE OF ILLINOIS DEPARTMENT OF TRANSPORTATION	EXISTING AND PROPOSED TYPICAL SECTIONS I-190 (O'HARE AIRPORT TO I-90)			F.A.I. RTE.	SECTION	COUNTY	TOTAL SHEETS	SHEET NO.
	PLOT SCALE = 100.0000' / in.	CHECKED -	REVISED -					190	(0101.6&0102.5)RS-2	COOK	85	10
PLOT DATE = 10/18/2012	DATE -	REVISED -	REVISED -	SCALE: SHEET NO. OF SHEETS STA. TO STA.			ILLINOIS FED. AID PROJECT CONTRACT NO. 60T33					