

MOMENT SLAB EXPANSION JOINT DETAIL

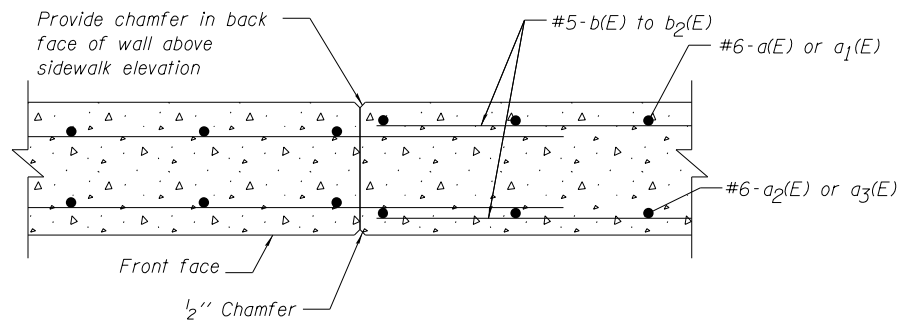

MOMENT SLAB AND PARAPET CONSTRUCTION JOINT DETAIL

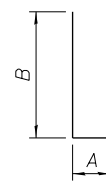
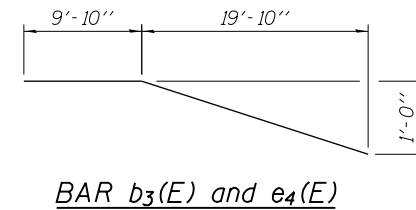
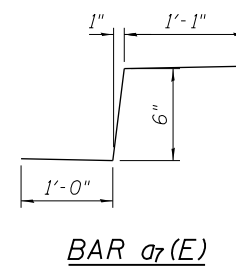
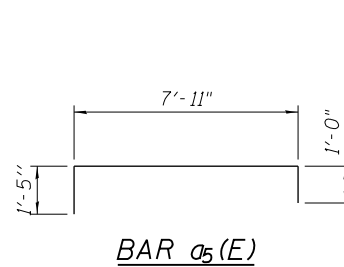
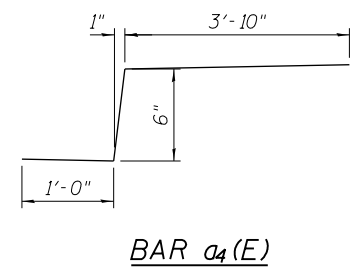
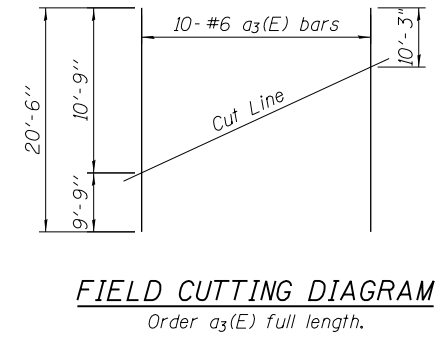
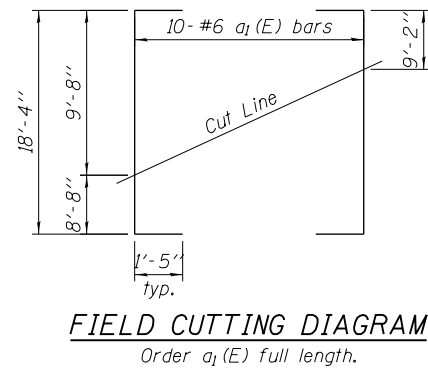
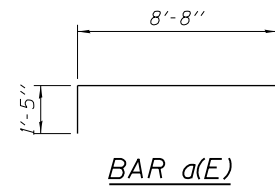

BARS d(E) THRU d₃(E)

| Bar | A | B |
|--------------------|-------|-------|
| d(E) | 10" | 5'-5" |
| d ₁ (E) | 1'-0" | 5'-5" |
| d ₂ (E) | 10" | 3'-3" |
| d ₃ (E) | 1'-0" | 3'-3" |

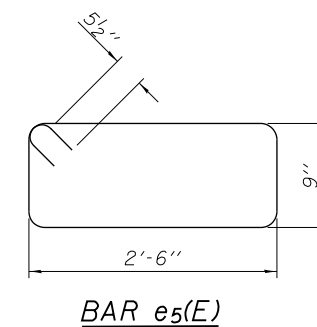

BILL OF MATERIAL

| Bar | No. | Size | Length | Shape |
|----------------------------------|-----|------|----------|--------|
| a(E) | 239 | #6 | 10'-1" | ┌ |
| a ₁ (E) | 10 | #6 | 21'-2" | ┌ |
| a ₂ (E) | 239 | #6 | 9'-9" | — |
| a ₃ (E) | 10 | #6 | 20'-6" | — |
| a ₄ (E) | 259 | #6 | 5'-4" | └ |
| a ₅ (E) | 16 | #6 | 10'-4" | ┌ |
| a ₆ (E) | 16 | #6 | 7'-9" | — |
| a ₇ (E) | 8 | #6 | 2'-7" | └ |
| b(E) | 23 | #5 | 29'-1" | — |
| b ₁ (E) | 115 | #5 | 33'-3" | — |
| b ₂ (E) | 68 | #5 | 29'-8" | — |
| b ₃ (E) | 3 | #5 | 29'-8" | — |
| d(E) | 116 | #5 | 7'-0" | L |
| d ₁ (E) | 116 | #6 | 7'-2" | L |
| d ₂ (E) | 200 | #5 | 4'-1" | L |
| d ₃ (E) | 200 | #6 | 4'-3" | L |
| e(E) | 6 | #5 | 29'-1" | — |
| e ₁ (E) | 3 | #5 | 9'-0" | — |
| e ₂ (E) | 30 | #5 | 33'-3" | — |
| e ₃ (E) | 12 | #5 | 29'-8" | — |
| e ₄ (E) | 6 | #5 | 29'-8" | — |
| e ₅ (E) | 96 | #5 | 7'-5" | □ |
| e ₆ (E) | 2 | #5 | 18'-10" | — |
| Reinforcement Bars, Epoxy Coated | | | Pound | 23,990 |
| Concrete Superstructure | | | Cu. Yds. | 190.6 |
| Parapet Railing, Special | | | Foot | 180 |

Bars indicated thus 1 x 15-#5 etc. indicates 1 line of bars with 15 lengths per line.

12/5/2012 5:46:42 PM - G:\CHIN\058\Bridges\CADD\Sheets\WALLA-DIB0135-08-WDET3.dgn



| | | |
|-----------------------------|----------------|-----------|
| USER NAME = jrmickow | DESIGNED - WJC | REVISED - |
| PLOT SCALE = 8/8" 1' = 1/4" | CHECKED - MDS | REVISED - |
| PLOT DATE = 12/5/2012 | DRAWN - WJC | REVISED - |
| | CHECKED - MDS | REVISED - |

**STATE OF ILLINOIS
DEPARTMENT OF TRANSPORTATION**

**DETAILS
RETAINING WALL A**

SHEET NO. 8 OF 10 SHEETS

| F.A.P. RTE. | SECTION | COUNTY | TOTAL SHEETS | SHEET NO. |
|--------------------|------------------------------|--------|---------------------------|-----------|
| 0305 | (1920.01,1518,2022&1922,4BIR | COOK | 919 | 488 |
| CONTRACT NO. 60T35 | | | ILLINOIS FED. AID PROJECT | |