

TYPE I ELASTOMERIC EXP. BRG.

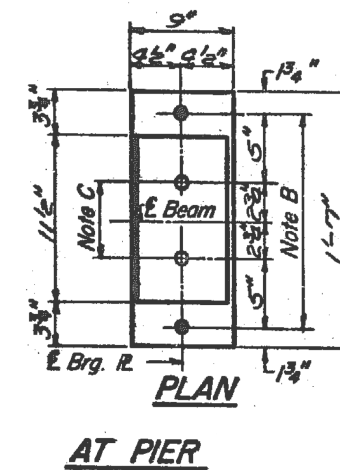
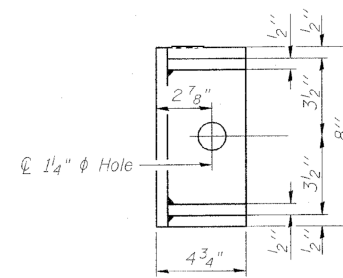
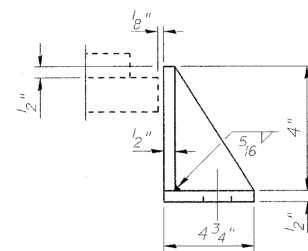
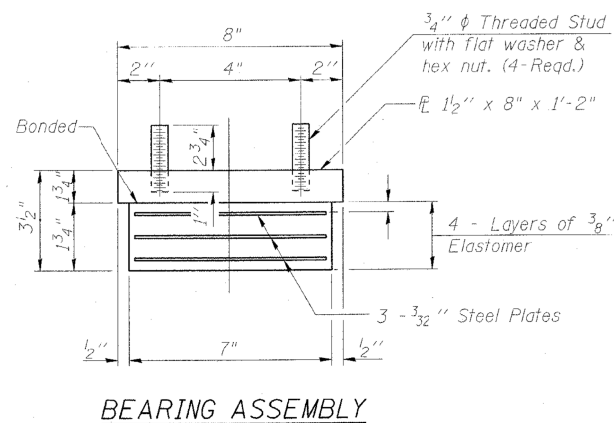
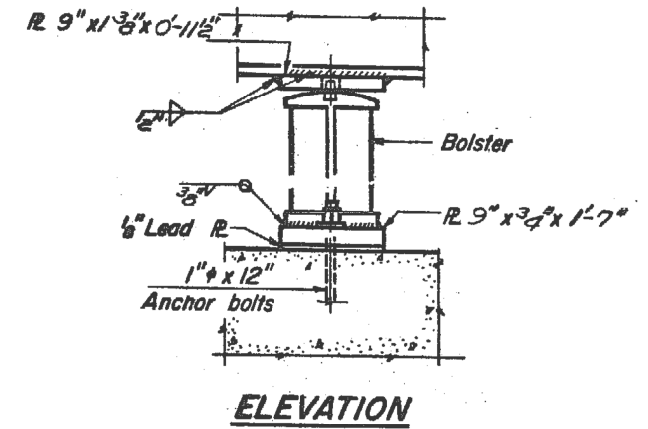
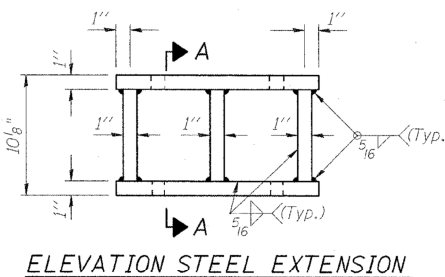
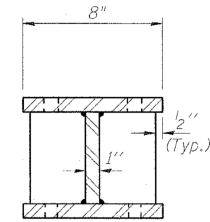
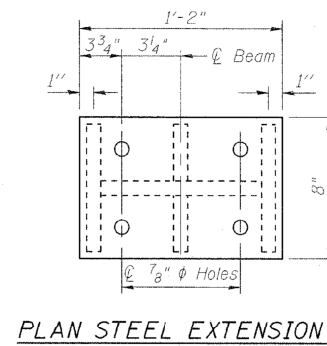
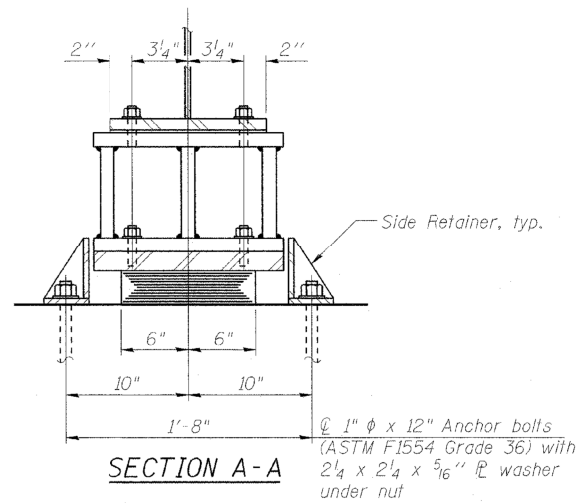

FILE NAME =	USER NAME = r1osfj	DESIGNED -	REVISED -
ei:\pw\work\p1dot\r1osfj\d0319439\0108613\sheet-plan.dgn		DRAWN -	REVISED -
	PLOT SCALE = 100.0000' / in.	CHECKED -	REVISED -
\$MODELNAME\$	PLOT DATE = 11/9/2012	DATE -	REVISED -

STATE OF ILLINOIS
DEPARTMENT OF TRANSPORTATION

LOCATION 3 (SN 016-0573)

SCALE: SHEET 3 OF 3 SHEETS STA. TO STA.

F.A. RTE.	SECTION	COUNTY	TOTAL SHEETS	SHEET NO.
VAR.	2012-074BP	COOK	27	18
			CONTRACT NO. 60V84	
ILLINOIS FED. AID PROJECT				