

| | | | | |
|---------------------|---------------------------|---------|--------------|-----------|
| F.A.P. RTE. | SECTION | COUNTY | TOTAL SHEETS | SHEET NO. |
| 311 | 11-11R | KENDALL | 514 | 430 |
| STA. | TO STA. | | | |
| FED. ROAD DIST. NO. | ILLINOIS FED. AID PROJECT | | | |

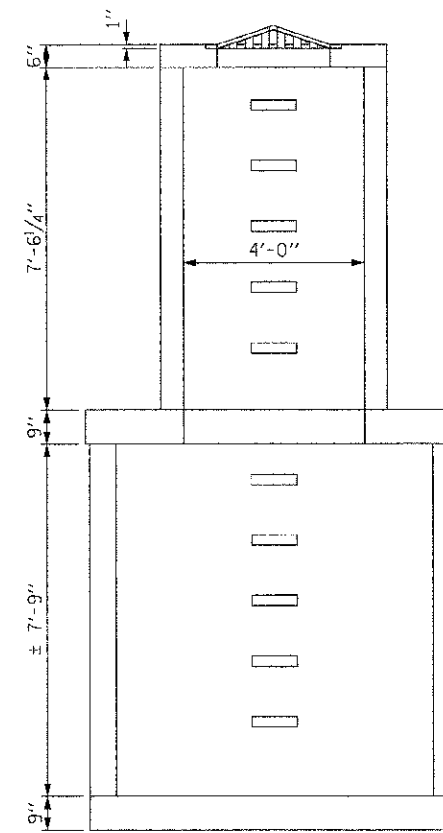

SECTION A-A

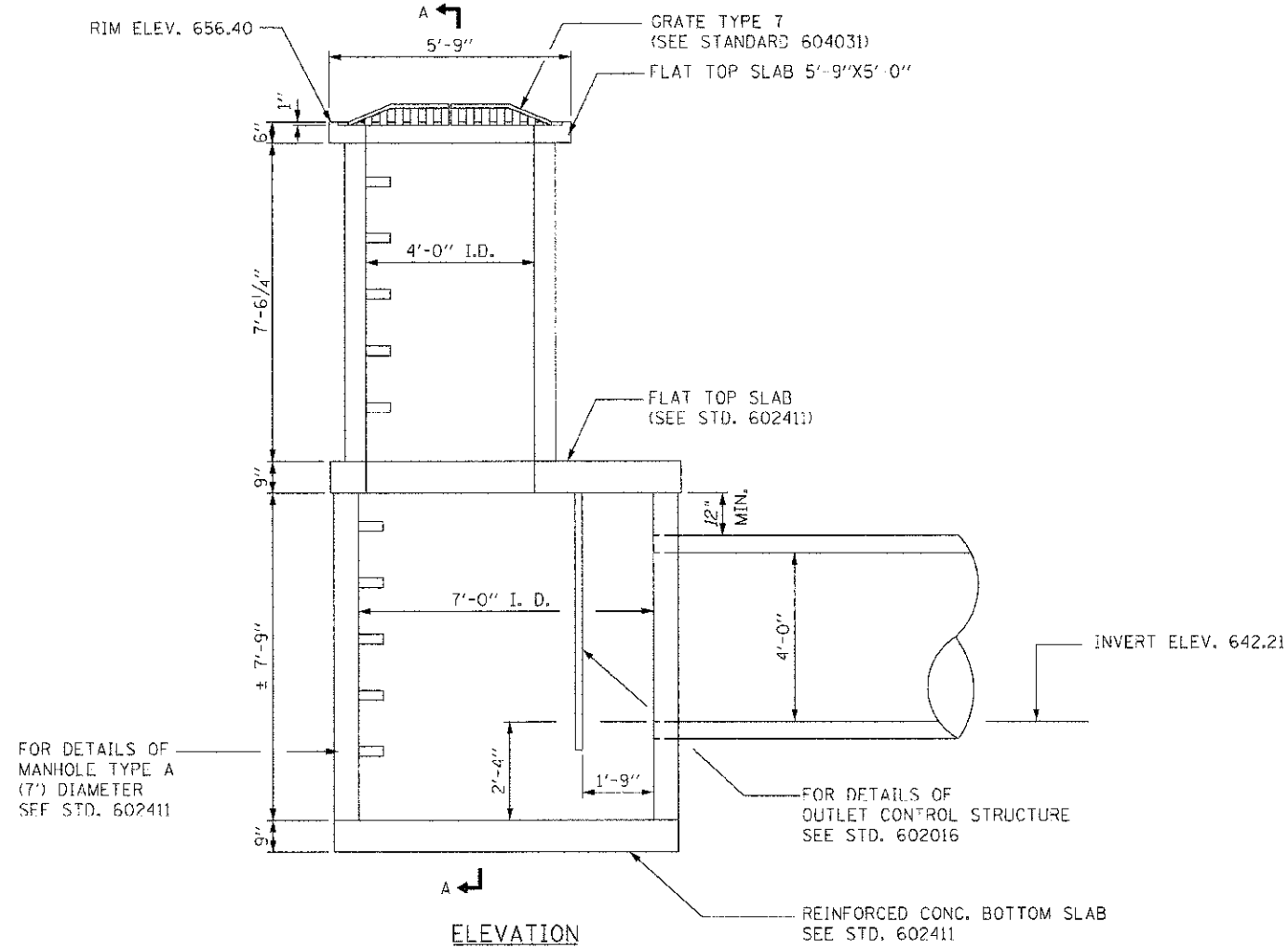
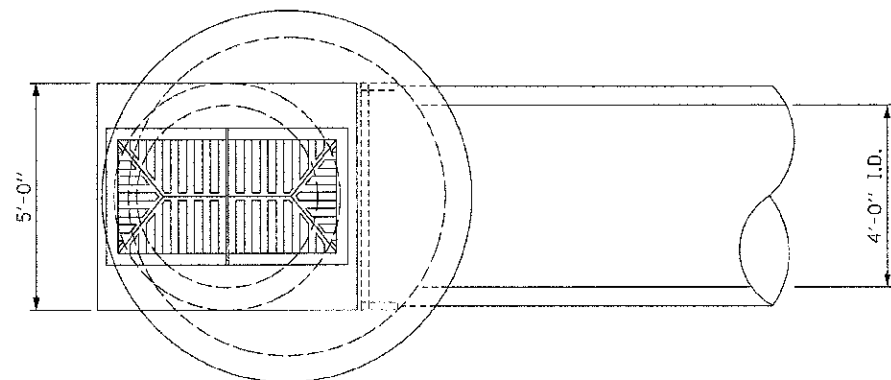

PLAN VIEW

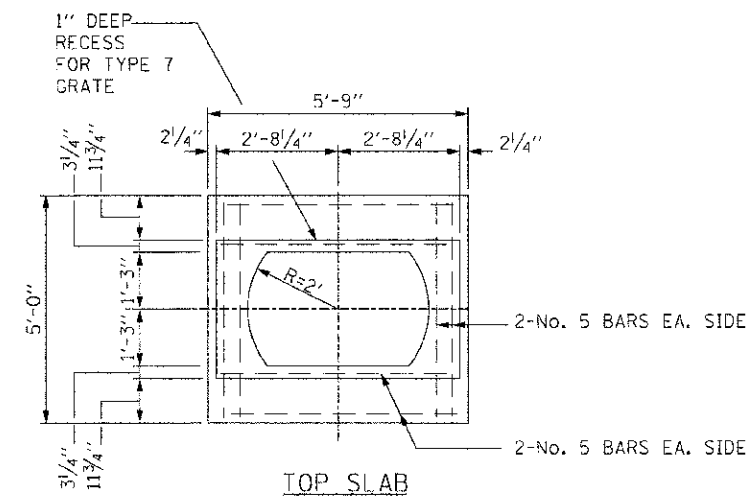

11-01-CB B SPC
 STA. 856+15.02

| REVISIONS | |
|-----------|------|
| NAME | DATE |
| | |
| | |
| | |
| | |
| | |
| | |
| | |
| | |
| | |

ILLINOIS DEPARTMENT OF TRANSPORTATION
**CATCH BASIN, TYPE B, 7' DIA
 (SPECIAL) DETAIL**

SCALE: VERT.
 HORIZ.
 DATE: 7/5/2012

DRAWN BY LP
 CHECKED BY MED

TUG PROJ. #3195914
 PLOT DATE = 7/5/2012
 FILE NAME = P:\CADD\11-EDD\DIST3\Omego\Phase 1\INDET16_CB.dgn