

**GENERAL NOTES**

1. Reinforcement bars designated (E) shall be epoxy coated.
2. Plan dimensions and details relative to existing plans are subject to nominal construction variations. The Contractor shall field verify existing dimensions and details affecting new construction and make necessary approved adjustments prior to construction or ordering of materials. Such variations shall not be cause for additional compensation for a change in scope of work; however, the Contractor will be paid for the quantity actually furnished at the unit price bid for the work.
3. Layout of slope protection system may be varied to suit ground conditions in the field as directed by the Engineer.
4. The Contractor shall make allowance for the deflection of forms, shrinkage and settlement of falsework, in addition to allowance for dead load deflection. Forms for deck slab shall be removed prior to placement of bridge approach slab.

**TOTAL BILL OF MATERIAL**

ITEM	UNIT	SUPER	SUB	TOTAL
Porous Granular Embankment, Special	Cu Yd		62	62
Stone Riprap, Class A4	Sq Yd		829	829
Filter Fabric	Sq Yd		829	829
Removal of Existing Superstructures	Each	1		1
Concrete Removal	Cu Yd		5.4	5.4
Structure Excavation	Cu Yd		70	70
Concrete Structures	Cu Yd		35.1	35.1
Concrete Superstructure	Cu Yd	325.3		325.3
Bridge Deck Grooving	Sq Yd	554		554
Protective Coat	Sq Yd	709		709
Reinforcement Bars, Epoxy Coated	Pound	106,530	6,660	113,190
Name Plates	Each			1
Preformed Joint Strip Seal	Foot	92		92
Epoxy Crack Injection	Foot		115	115
Geocomposite Wall Drain	Sq Yd		40	40
Asbestos Bearing Pad Removal	Each		18	18
Structural Repair of Concrete (Depth Equal to or Less than 5 inches)	Sq Ft		7	7
Pipe Underdrains For Structures, 4"	Foot		146	146

**INDEX OF SHEETS**

- SA-01. General Plan
- SA-02. General Data
- SA-03. Top of Slab Elevations
- SA-04. North Approach Slab Elevations
- SA-05. South Approach Slab Elevations
- SA-06. Superstructure
- SA-07. Superstructure Details 1
- SA-08. Superstructure Details 2
- SA-09. Concrete Parapet Slipforming Option
- SA-10. Preformed Joint Strip Seal
- SA-11. Bridge Approach Slab Details
- SA-12. Bridge Approach Slab Details
- SA-13. North Abutment Repairs
- SA-14. South Abutment Repairs
- SA-15. Pier Repairs

STATION 1741+39.10  
REBUILT 201\_ BY  
STATE OF ILLINOIS  
F.A.P. RT. 796  
SEC. (106 BR-1 & BR-4)BR  
LOADING HL-93  
STR. NO. 027-0072

**NAME PLATE**  
See Std. 515001

Existing Name Plate shall be cleaned and relocated next to the new Name Plate. Cost included with Name Plates.

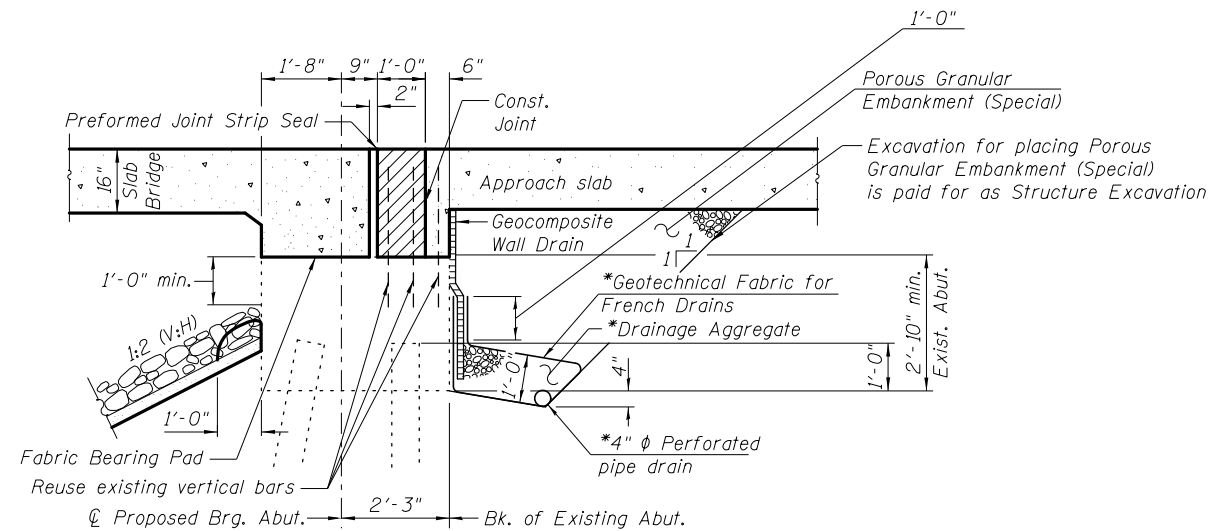

**SECTION THRU ABUTMENT**  
(Horizontal dimensions are at right angles)

\* Included in the cost of Pipe Underdrains for Structures.

All drainage system components shall extend to 2'-0" from the end of each wingwall except an outlet pipe shall extend until intersecting with the side slopes. The pipes shall drain into concrete headwalls. (See Article 601.05 of the Standard Specifications and Highway Standard 601101).

**GENERAL DATA**  
**STRUCTURE NO. 027-0072**

FILE NAME = \$FILEL\$



Zroka Engineering, P.C.  
4216 North Hermitage  
Chicago, IL 60613

USER NAME = \$USER\$	DESIGNED - LAS	REVISED -
	CHECKED - DAZ	REVISED -
PLOT SCALE = \$SCALE\$	DRAWN - SAW	REVISED -
PLOT DATE = \$DATE\$	CHECKED - LAS	REVISED -

**STATE OF ILLINOIS**  
**DEPARTMENT OF TRANSPORTATION**

**GENERAL DATA**  
**S.N. 027-0072**

SHEET NO. SA-02 OF SA-15 SHEETS

F.A.P. RTE.	SECTION	COUNTY	TOTAL SHEETS	SHEET NO.
796	(106 BR-1 & BR-4)BR	FORD	78	34
CONTRACT NO. 66980			ILLINOIS FED. AID PROJECT	