

PLAN

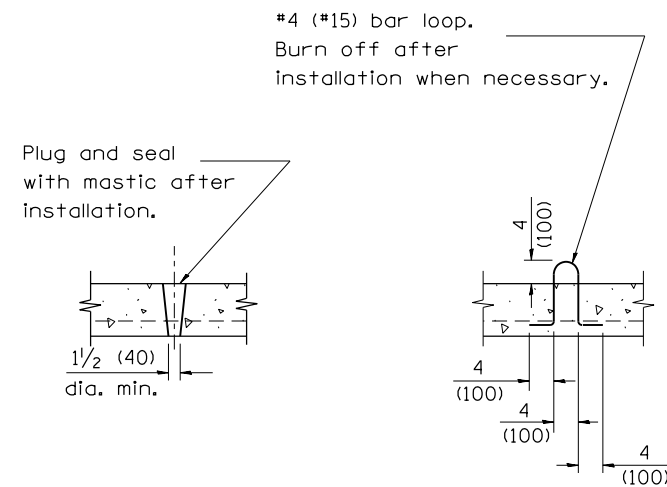

LIFTING HOLE OR LIFTING LOOP  
TYPICAL

(3 required per slab)

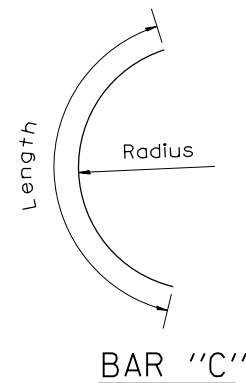

BAR "C"

TABLE

D	T	D <sub>o</sub> (min.)	t	Reinforcement "As" W.W.F. each direction	Bar size	No. 15 (No. 4) Bar C	
						Length	Radius
4' (1.2m)	5 (125)	4'-10" (1.5m)	6 (150)	0.70 sq. inch/lin. ft. (1480mm <sup>2</sup> /m)	No. 15 (No. 5)	1.35m (4'-6")	660 (26)
5' (1.5m)	6 (150)	6'-0" (1.8m)	8 (200)	0.70 sq. inch/lin. ft. (1480mm <sup>2</sup> /m)	No. 15 (No. 5)	1.5m (5'-0")	810 (32)
6' (1.8m)	7 3/4 (195)	7'-3 1/2" (2.2m)	8 (200)	0.88 sq. inch/lin. ft. (1860mm <sup>2</sup> /m)	No. 20 (No. 6)	1.8m (6'-0")	965 (38)
8' (2.4m)	9 (225)	9'-6" (2.9m)	10 (250)	0.88 sq. inch/lin. ft. (1860mm <sup>2</sup> /m)	No. 20 (No. 6)	2.3m (7'-6")	1.27m (4'-2")

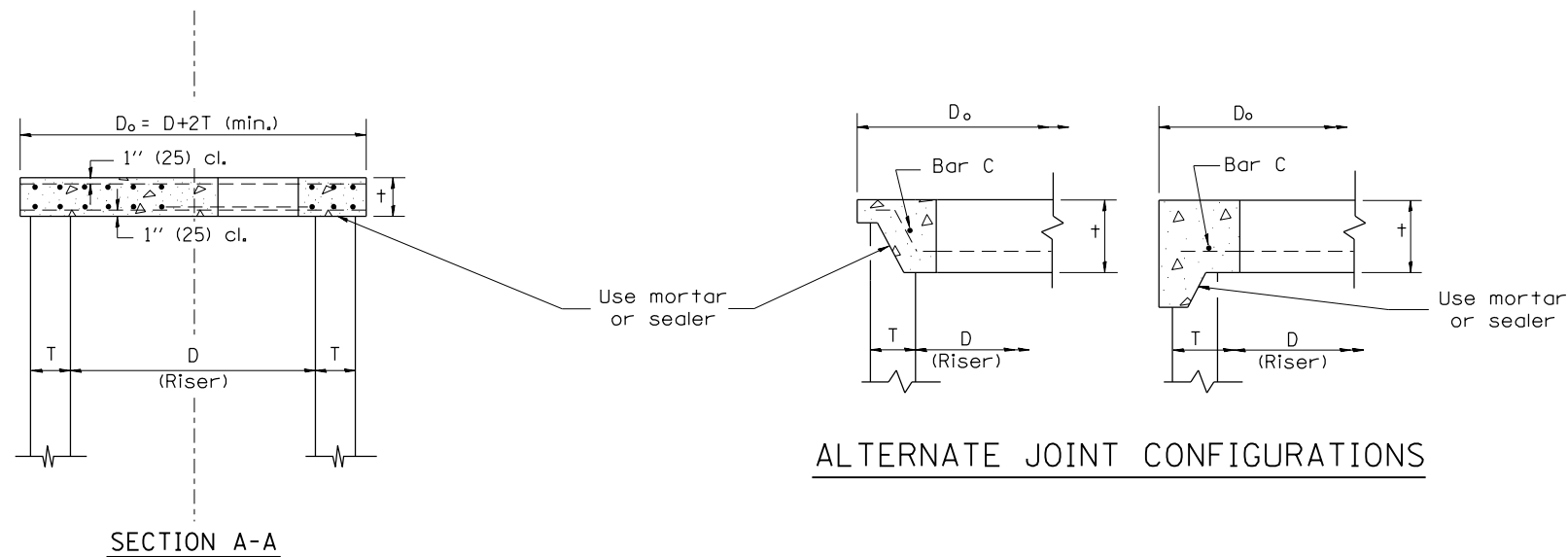

GENERAL NOTES

1. The precast reinforced concrete flat slab top shall be used with INLET-MANHOLE, TYPE G-1 and INLET-MANHOLE, TYPE G-1, SPECIAL.
2. Joint configuration and dimensions of flat slab top shall match and fit the riser joint detail.
3. Lifting devices shall be approved by the Engineer.

All dimensions are in inches (millimeters) unless otherwise noted.