

RAMPS 1 & 2 (I-255 & I-55/70)

RAMP 1 STA 102+30 TO STA 113+50
 RAMP 2 STA 200+00 TO STA 225+13

• WIDTH TRANSITION FROM STA 111+50 TO STA 113+50

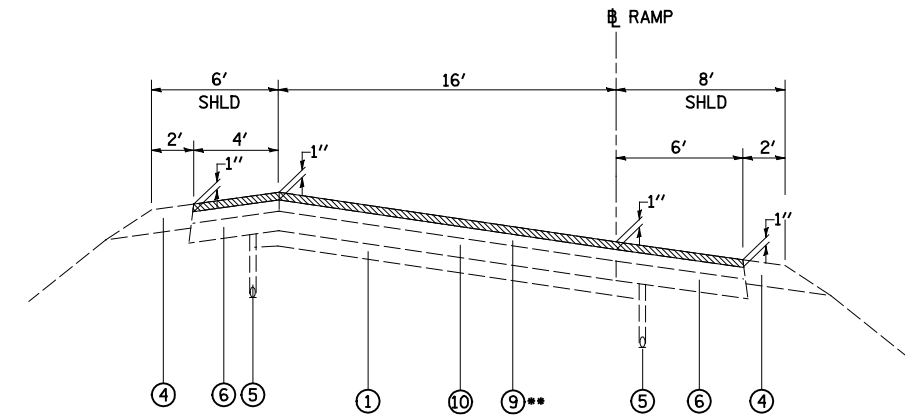

RAMPS 3-4 (I-255 & I-55/70)

RAMP 3 STA 300+00 TO STA 315+54.92**
 RAMP 4 STA 400+00 TO STA 412+76**

** EXISTING RESURFACING AND PROPOSED
 HMA SURFACE REMOVAL, 1" ONLY
 FROM STA 311+30 TO STA 315+55 (RAMP 3) AND
 FROM STA 400+00 TO STA 403+54 (RAMP 4)

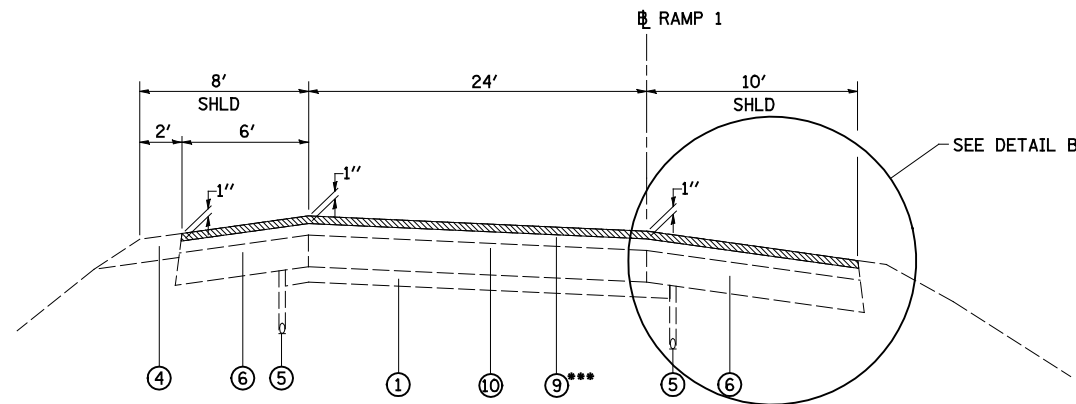

RAMP 1 (I-255 & I-55/70)

STA 113+50 TO STA 139+42
 STA 142+26 TO STA 160+76

BRIDGE OMISSION STA 139+42 TO STA 142+26
 *** EXISTING RESURFACING AND HMA SURFACE REMOVAL, 1"
 OMISSION STA 138+13 TO STA 143+69

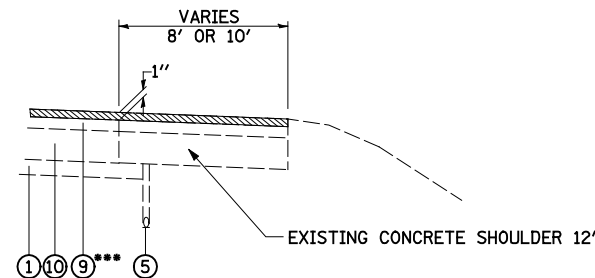

DETAIL B

STA 133+84 TO STA 139+01 LT
 STA 133+84 TO STA 139+39 RT
 STA 142+26 TO STA 145+35 LT
 STA 142+42 TO STA 147+39 RT

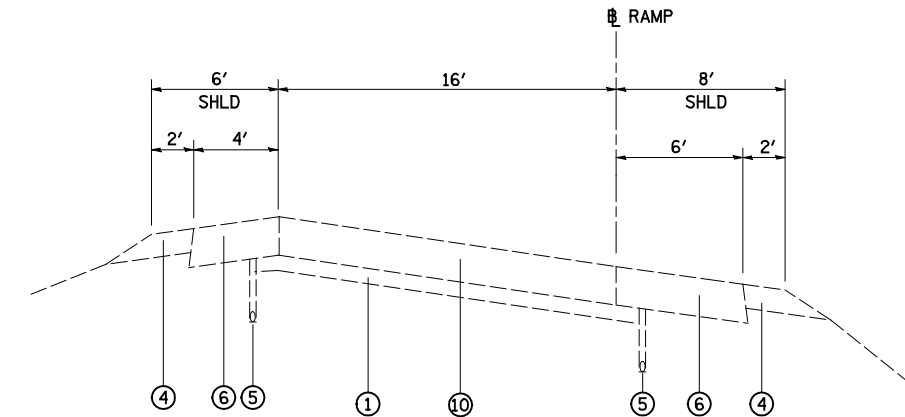

RAMPS 5-6 (I-255 & I-55/70)

RAMP 5 STA 500+00 TO STA 517+32
 RAMP 6 STA 600+00 TO STA 617+75

LEGEND

- ① EXISTING STABILIZED SUB-BASE 4"
- ② EXISTING CRPCC PAVEMENT 10"
- ③ EXISTING ASPHALT RESURFACING 2 1/4"
- ④ EXISTING AGGREGATE SHOULDERS TYPE B
- ⑤ EXISTING PIPE UNDERDRAINS 4"
- ⑥ EXISTING HOT-MIX ASPHALT SHOULDER 10"
- ⑦ EXISTING TEMPORARY CONCRETE BARRIER
- ⑧ EXISTING BITUMINOUS CURB
- ⑨ EXISTING ASPHALT RESURFACING, 3 3/4"
- ⑩ EXISTING PCC PAVEMENT 10" (REINFORCED)
- ⑪ EXISTING PCC PAVEMENT 8" (REINFORCED)
- ⑫ EXISTING HOT-MIX ASPHALT SHOULDER 8"
- ⑬ EXISTING APPROACH SLAB
- ⑭ EXISTING A-3 SURFACE TREATMENT
- ⑮ EXISTING AGGREGATE BASE COURSE, TYPE A 15"
- ▨ HOT-MIX ASPHALT SURFACE REMOVAL, 1"

NOTE: FOR LIMITS OF REMOVAL ITEMS
 SEE REMOVAL SHEETS

▨ REMOVAL ITEMS

FILE NAME = #FILEL#	USER NAME = Paul	DESIGNED - ESW	REVISED -	STATE OF ILLINOIS DEPARTMENT OF TRANSPORTATION	EXISTING TYPICAL SECTIONS FAI ROUTE 255 RAMPS AT FAI ROUTE 55/70			F.A.I. RTE. 255	SECTION 60-(7,8)RS-2	COUNTY MADISON	TOTAL SHEETS 261	SHEET NO. 20
PLOT SCALE = 100.0000' / IN.		DRAWN - PDB	REVISED -		SCALE:	SHEET NO. 6 OF 8 SHEETS	STA.	TO STA.	CONTRACT NO. 76A89		ILLINOIS FED. AID PROJECT	
PLOT DATE = 7/31/2012		CHECKED - BRM	REVISED -									
		DATE - 8-29-11	REVISED -									