

Notes: Driving and bearing ends of pipe shall be cut square. The thickness of the shell shall be 0.25 inches with a tolerance of 5%. The shell shall be according to Article 1006.05(a) of the Standard Specifications, and shall be ASTM A252 Grade 3.

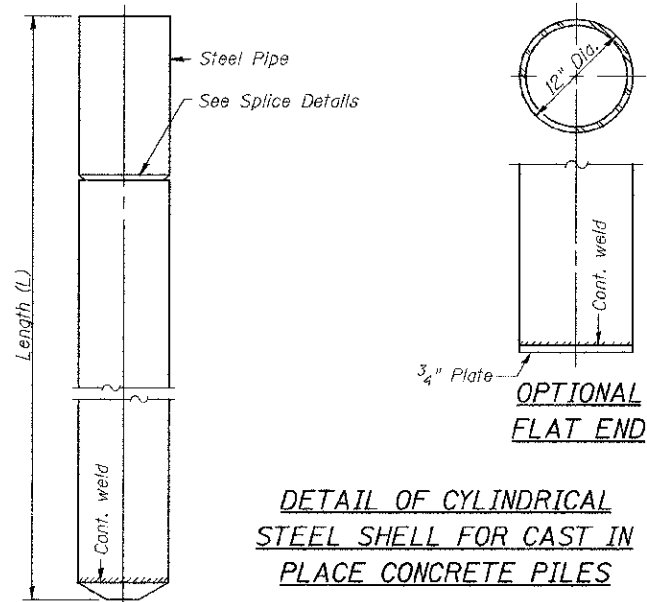

**DETAIL OF CYLINDRICAL STEEL SHELL FOR CAST IN PLACE CONCRETE PILES**

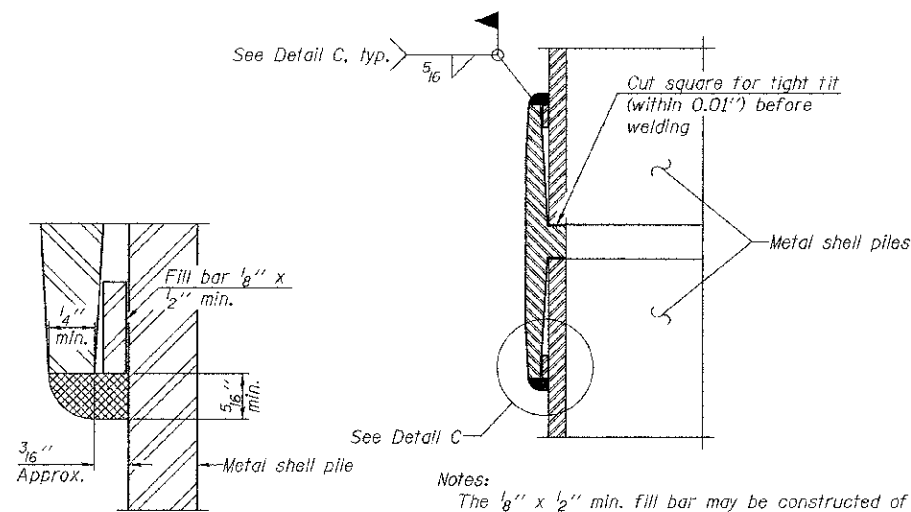

Notes:  
The  $\frac{1}{8}'' \times \frac{1}{2}''$  min. fill bar may be constructed of 2 bars with a  $\frac{1}{8}''$  max. gap between them.  
Pile segments shall be driven to solid contact with splicer before welding.

**WELDED COMMERCIAL SPLICE**

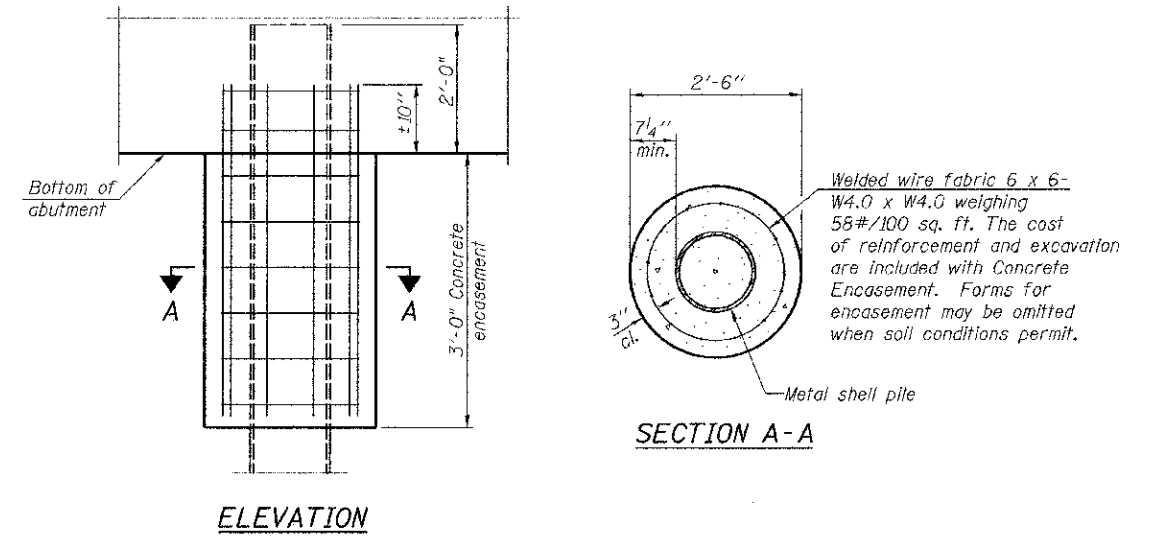

**CONCRETE ENCASEMENT AT ABUTMENTS**

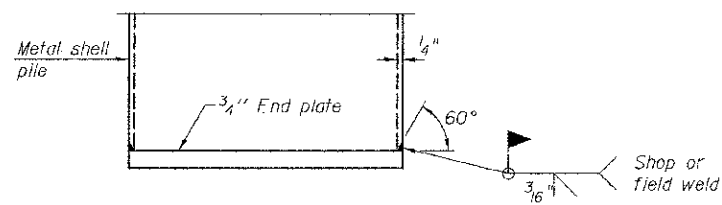

**END PLATE ATTACHMENT**

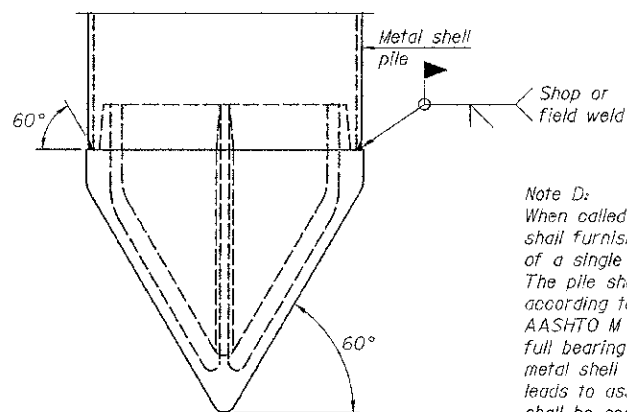

**METAL SHELL PILE SHOE ATTACHMENT**  
(See Note D)

Note D:  
When called for on the plans, the Contractor shall furnish metal shell pile shoes consisting of a single piece conical pile point as shown. The pile shoes shall be cast in one piece steel according to either ASIM A 148 Grade 90-60 or AASHTO M 103 Grade 65-35 and shall provide full bearing over the full circumference of the metal shell pile. The pile shoe shall have tapered leads to assure proper alignment and fitting and shall be secured to the pile with a circumferential weld.

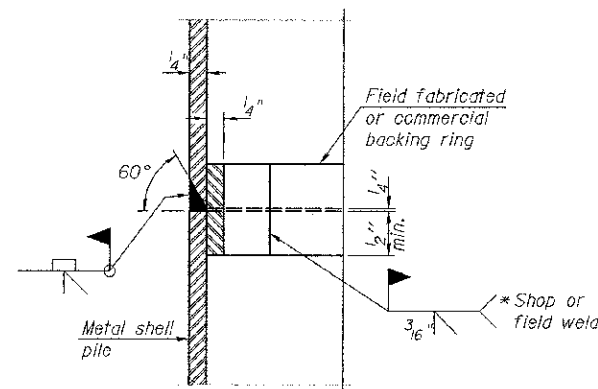

**COMPLETE PENETRATION WELD SPLICE**  
\* Field fabricated backing ring may be made from pile shell by removing segment to allow reducing circumference and vertically rejoin with partial joint penetration weld.

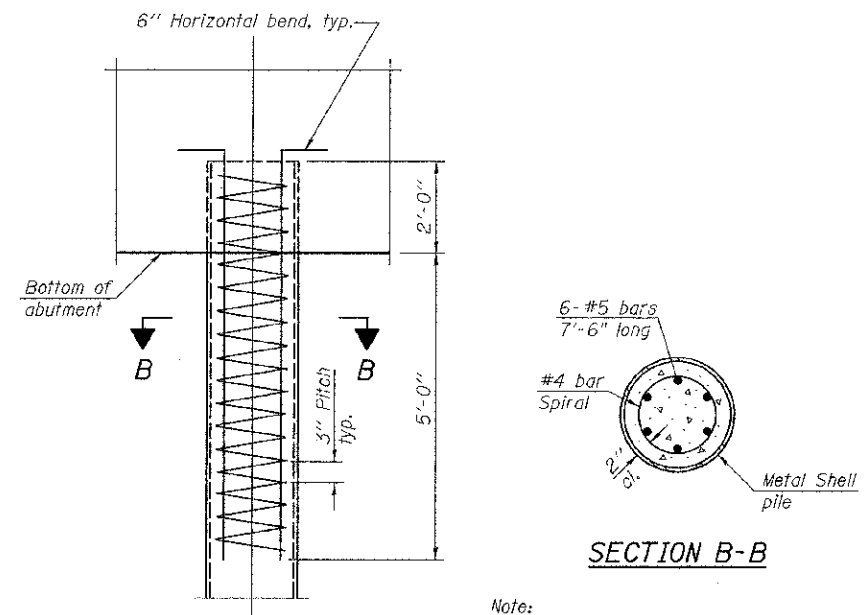

**METAL SHELL REINFORCEMENT AT ABUTMENTS**

Note:  
The cost of reinforcement is included with Furnishing Metal Shell Piles 12"x0.250".

**METAL SHELL PILE DETAILS**  
**COUNTY HIGHWAY 9 OVER**  
**LOUIS CREEK TRIBUTARY**  
**SEC. 08-00130-02-BR**  
**IROQUOIS COUNTY**  
**STATION 214+96.00**

SHEET NO. 12 15 SHEETS	F.A.S. RTE.	SECTION	COUNTY	TOTAL SHEETS	SHEET NO.
	334	08-00130-02-BR	IROQUOIS	27	18
	S.N. 038-3014		CONTRACT NO. 87524		
FED. ROAD DIST. NO. 7 ILLINOIS		FED. AID PROJECT BRS-0334(113)			