

F.A.P. RTE.	SECTION	COUNTY	TOTAL SHEETS	SHEET NO.
635	(105)BR-2	KANKAKEE	25	19
STA.		TO STA.		
FED. ROAD DIST. NO.		ILLINOIS	FED. AID PROJECT	

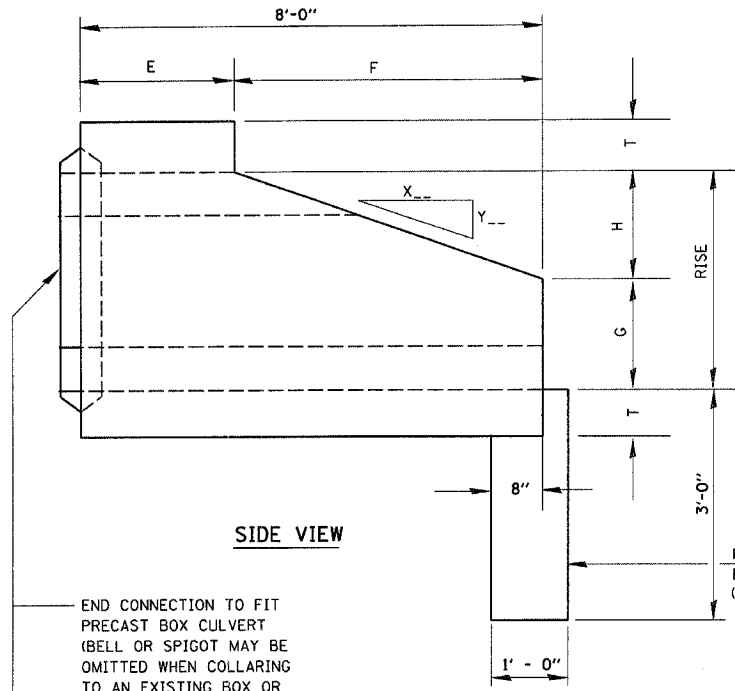

SIDE VIEW

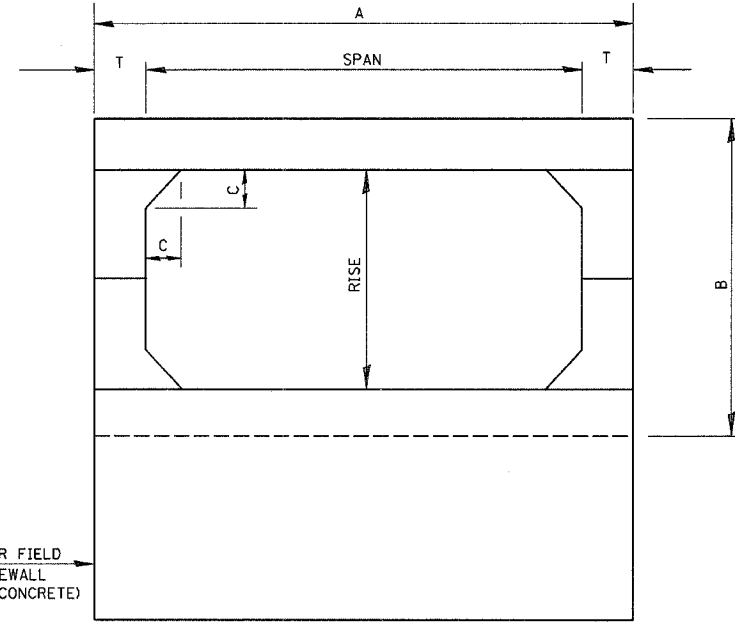

END VIEW

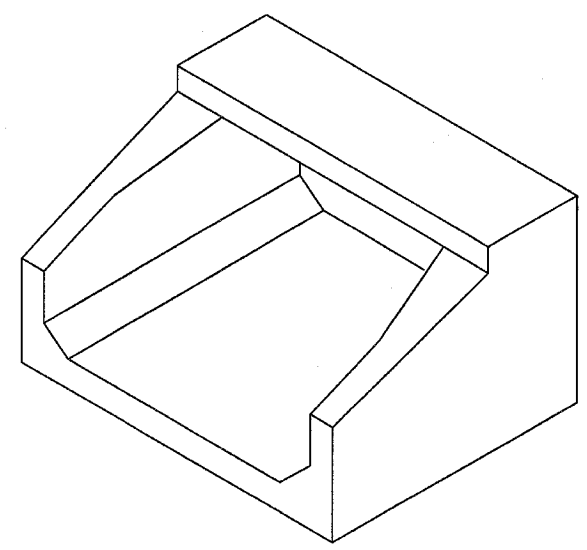

ISOMETRIC VIEW

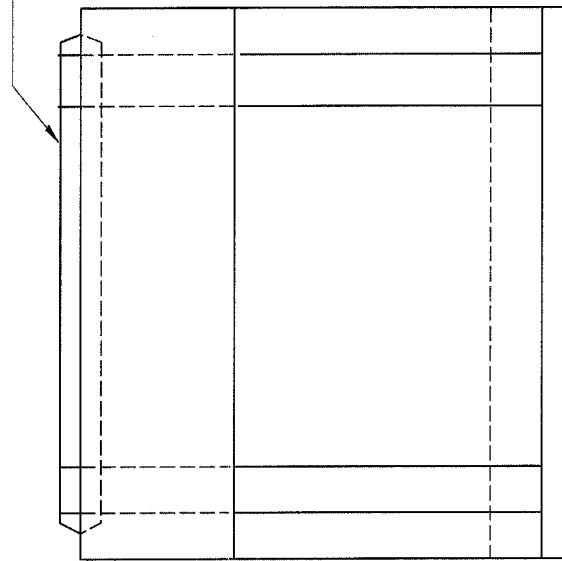

PLAN

PRECAST OR FIELD
POURED TOEWALL
(CLASS S1 CONCRETE)

SPAN X RISE	T (INCHES)	A (FT.-IN.)	B (FT.-IN.)	C (INCHES)	E (FT.-IN.)	F (FT.-IN.)	G (FT.-IN.)	H (FT.-IN.)	SLOPE
2' X 2'	4	2 - 8	2 - 8	4	3 - 0	3 - 0	1 - 0	1 - 0	3 : 1
3' X 2'	4	3 - 8	2 - 8	4	3 - 0	3 - 0	1 - 0	1 - 0	3 : 1
3' X 3'	4	3 - 8	3 - 8	4	2 - 0	4 - 0	1 - 8	1 - 4	3 : 1
4' X 2'	5	4 - 10	2 - 10	5	3 - 0	3 - 0	1 - 0	1 - 0	3 : 1
4' X 3'	5	4 - 10	3 - 10	5	2 - 0	4 - 0	1 - 8	1 - 4	3 : 1
4' X 4'	5	4 - 10	4 - 10	5	2 - 0	4 - 0	2 - 0	2 - 0	2 : 1
5' X 2'	6	6 - 0	3 - 0	6	3 - 0	3 - 0	1 - 0	1 - 0	3 : 1
5' X 3'	6	6 - 0	4 - 0	6	2 - 0	4 - 0	1 - 8	1 - 4	3 : 1
5' X 4'	6	6 - 0	5 - 0	6	2 - 0	4 - 0	2 - 0	2 - 0	2 : 1
5' X 5'	6	6 - 0	6 - 0	6		4 - 0	3 - 0	2 - 0	2 : 1
6' X 2'	7	7 - 2	3 - 2	7	3 - 0	3 - 0	1 - 0	1 - 0	3 : 1
6' X 3'	7	7 - 2	4 - 2	7	2 - 0	4 - 0	1 - 8	1 - 4	3 : 1
6' X 4'	7	7 - 2	5 - 2	7	2 - 0	4 - 0	2 - 0	2 - 0	2 : 1
6' X 5'	7	7 - 2	6 - 2	7		4 - 0	3 - 0	2 - 0	2 : 1
7' X 3'	8	8 - 4	4 - 4	8		4 - 0	1 - 8	1 - 4	3 : 1
7' X 4'	8	8 - 4	5 - 4	8		4 - 0	2 - 0	2 - 0	2 : 1
7' X 5'	8	8 - 4	6 - 4	8		4 - 0	3 - 0	2 - 0	2 : 1
8' X 3'	8	9 - 4	4 - 4	8		4 - 0	1 - 8	1 - 4	3 : 1
8' X 4'	8	9 - 4	5 - 4	8		4 - 0	2 - 0	2 - 0	2 : 1
8' X 5'	8	9 - 4	6 - 4	8		4 - 0	3 - 0	2 - 0	2 : 1
9' X 3'	9	10 - 6	4 - 6	9		4 - 0	1 - 8	1 - 4	3 : 1
9' X 4'	9	10 - 6	5 - 6	9		4 - 0	2 - 0	2 - 0	2 : 1
9' X 5'	9	10 - 6	6 - 6	9		4 - 0	3 - 0	2 - 0	2 : 1
10' X 4'	10	11 - 8	5 - 9	10		4 - 0	2 - 0	2 - 0	2 : 1
11' X 4'	11	12 - 10	5 - 10	11		6 - 0	2 - 6	1 - 6	4 : 1

8/31/2005 12:49:54 PM c:\p\proj\sec's\66456\003\66456.dwg

ILLINOIS DEPARTMENT OF TRANSPORTATION

DETAILS