

F.A.P. RTE.	SECTION	COUNTY	TOTAL SHEETS	SHEET NO.
41	15 BR	LIVINGSTON	38	4
FED. ROAD DIST. NO. 7 ILLINOIS FED. AID PROJECT				
CONTRACT NO. 66665				

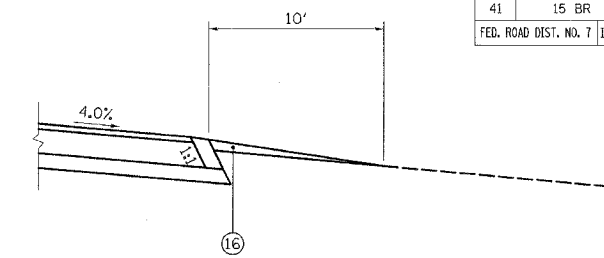
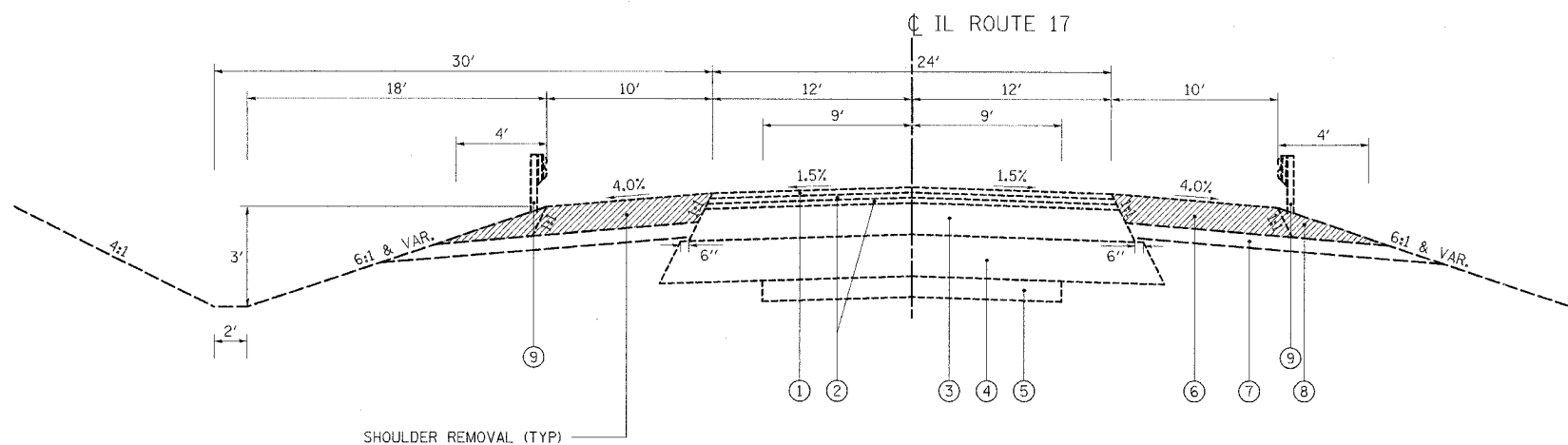

THE FOLLOWING MIXTURE REQUIREMENTS ARE APPLICABLE FOR THIS PROJECT:

	HMA LEVEL BINDER PG64-22	HMA SURFACE PG64-22	HMA SHOULDER PG58-22
PG GRADE	PG64-22	PG64-22	PG58-22
MAX % RAP ALLOWABLE **	25%	15%	50%
DESIGN AIR VOIDS	4.0% @ N50	4.0% @ N50	2.0% @ N30
MIXTURE COMPOSITION	IL 9.5	IL 12.5 OR IL 9.5	BAM
FRICITION AGGREGATE DENSITY TEST METHOD	SATISFACTION OF ENGINEER	MIXTURE C NUCLEAR / CORES	NUCLEAR / CORES

\*\* IF RAP OPTION IS SELECTED, THE ASPHALT CEMENT GRADE MAY NEED TO BE ADJUSTED. THIS WILL BE DETERMINED BY THE ENGINEER.

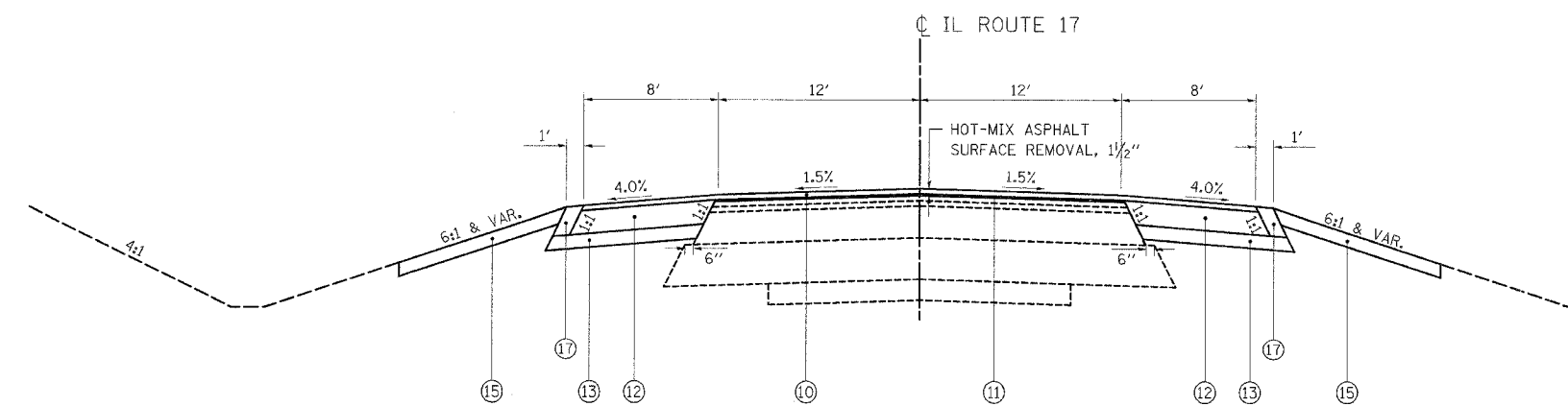
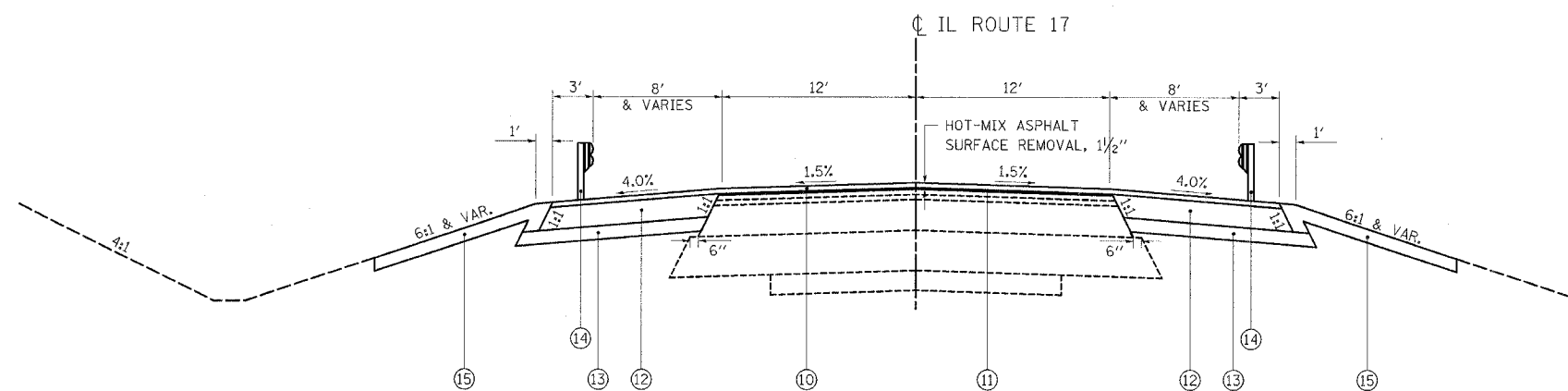

**LEGEND**

- ① EXISTING HMA SURFACE COURSE, CLASS I, 1 1/2"
- ② EXISTING HMA BINDER COURSE, 1 1/2"
- ③ EXISTING STABILIZED BASE COURSE, 9"
- ④ EXISTING STABILIZED BASE COURSE, 3" MIN., 12" MAX.
- ⑤ EXISTING P.C.C. PAVEMENT
- ⑥ EXISTING STABILIZED SHOULDERS, 8"
- ⑦ EXISTING SUB-BASE GRANULAR MATERIAL TYPE C, 4"
- ⑧ EXISTING AGGREGATE SHOULDERS, TYPE A
- ⑨ EXISTING GUARDRAIL
- ⑩ HOT-MIX ASPHALT SURFACE COURSE, MIX "C", N50, 1 1/2"
- ⑪ LEVELING BINDER (MACHINE METHOD), N50, VAR. DEPTH
- ⑫ HOT-MIX ASPHALT SHOULDERS, 6 1/2"
- ⑬ SUB-BASE GRANULAR MATERIAL, TYPE B 4"
- ⑭ PROPOSED GUARDRAIL
- ⑮ VEGETATION SUSTAINING TOPSOIL, 4" (SEE NOTE BELOW)
- ⑯ AGGREGATE SURFACE COURSE, TYPE B
- ⑰ AGGREGATE SHOULDERS, TYPE B

NOTE: REUSE EXISTING TOPSOIL WHENEVER POSSIBLE. WHEN EXISTING QUANTITY OF ON-SITE TOPSOIL IS DEFICIENT, VEGETATION SUSTAINING TOPSOIL WILL BE HAULED FROM OFF SITE AND PAID FOR AS FURNISHED EXCAVATION

<p>Excellence through Ownership</p> <p>200 West Front Street Wheaton, IL 60187</p>	<b>REVISIONS</b> NAME      DATE		ILLINOIS DEPARTMENT OF TRANSPORTATION F.A.P. ROUTE 41 (IL 17)  <b>TYPICAL SECTIONS</b>  SCALE: VERT. NOT TO SCALE      DRAWN BY: NEC HORIZ.                                      CHECKED BY: SPF DATE: OCTOBER 20, 2006

07/20/2006 17:42:45 AM K:\10266666\Coord\Design\20666666\Typ.dgn